

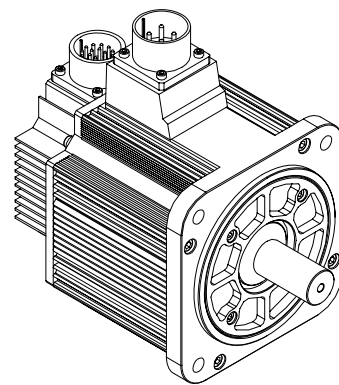

# ProNet-E Series AC Servo User's Manual

(Version: V1.00)

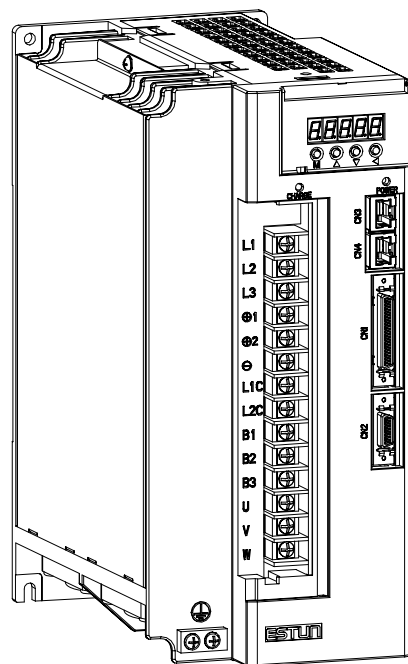

ESTUN AUTOMATION TECHNOLOGY CO., LTD

— Drive Your Success



Copyright © 2012ESTUN AUTOMATION TECHNOLOGY CO., LTD

---

All rights reserved. No part of this publication may be reproduced, stored in a retrieval system, or transmitted, in any form, or by any means, mechanical, electronic, photocopying, recording, or otherwise, without the prior written permission of ESTUN. No patent liability is assumed with respect to the use of the information contained herein.

# About this manual

■ This manual describes the following information required for designing and maintaining ProNet series servodrives.

- Specification of the servodrives and servomotors.
- Procedures for installing the servodrives and servomotors.
- Procedures for wiring the servodrives and servomotors.
- Procedures for operation of the servodrives.
- Procedures for using the panel operator.
- Communication protocols.
- Ratings and characteristics.

■ Intended Audience:

- Those designing ProNet-E series servodrive systems.
- Those installing or wiring ProNet-E series servodrives.
- Those performing trial operation or adjustments of ProNet-E series servodrives.
- Those maintaining or inspecting ProNet-E series servodrives.

# Safety Precautions

---

- Do not connect the servomotor directly to the local electrical network.

Failure to observe this may result in damage to servomotor.

- Do not plug or unplug connectors from servodrive after power is on.

Failure to observe this may result in damage to servodrive and servomotor.

- Note that residual voltage still remains in the servodrive even after the power is turned off.

Please be noted that even after the power is turned off, residual voltage still remains in the capacitor inside the servodrive. If inspection is to be performed after the power is turned off, always wait at least 5 minutes to avoid the risk of an electrical shock.

- Keep servodrives and other devices separated by at least 10mm.

The servodrive generates heat. Install the servodrive so that it can radiate heat freely. When installing servodrives with other devices in a control panel, provide at least 10mm space between them and 50mm space above and below them. Please install servodrives in an environment free from condensation, vibration and shock.

- Perform noise reduction and grounding properly.

Please comply with the following instructions strictly to avoid the noisy generated by signal lines.

1. Separate high-voltage cables from low-voltage cables.
2. Use cables as short as possible.
3. Single point grounding is required for the servomotor and servodrive (grounding resistance 100Ω or below).
4. Never use a line filter for the power supply in the circuit.

- Conduct a voltage resistance test for the servodrive under the following conditions:

1. Input voltage: AC 1500Vrms, 1 minute
2. Braking current: 100mA
3. Frequency: 50/60Hz
4. Voltage applied point: Between L1, L2, L3 terminals and frame ground.

- Use a fast-response type ground-fault interrupter.

For a ground-fault interrupter, always use a fast-response type or one designed for PWM inverters. Do not use a time-delay type.

- Do not make any extreme adjustments or setting changes of parameters.

Failure to observe this caution may result in injury or damage to the product due to unstable operation.

- The servomotor cannot be operated by turning the power on and off.

Frequently turning the power ON and OFF causes the internal circuit elements to deteriorate, resulting in unexpected problems. Always start or stop the servomotor by using reference pulses.

# —Contents—

About this manual .....	- 1 -
Safety Precautions .....	- 2 -
Chapter 1 .....	- 7 -
Checking Products and Parts Names .....	- 7 -
1.1 Checking Products on Delivery .....	- 7 -
1.1.1 Servomotor .....	- 7 -
1.1.2 Servodrive .....	- 8 -
1.2 Part Names .....	- 10 -
1.2.1 Servomotor .....	- 10 -
1.2.2 Servodrive .....	- 10 -
Chapter 2 .....	- 13 -
Installation .....	- 13 -
2.1 Servomotor .....	- 13 -
2.1.1 Storage .....	- 13 -
2.1.2 Installation Sites .....	- 13 -
2.1.3 Installation Alignment .....	- 14 -
2.1.4 Installation Orientation .....	- 14 -
2.1.5 Handling Oil and Water .....	- 14 -
2.1.6 Cable Tension .....	- 15 -
2.2 Servodrive .....	- 15 -
2.2.1 Storage .....	- 15 -
2.2.2 Installation Sites .....	- 15 -
2.2.3 Installation Orientation .....	- 15 -
2.2.4 Installation Method .....	- 16 -
Chapter 3 .....	- 17 -
Wiring .....	- 17 -
3.1 Main Circuit Wiring .....	- 17 -
3.1.1 Names and Functions of Main Circuit Terminals .....	- 17 -
3.1.2 Typical Main Circuit Wiring Examples .....	- 18 -
3.2 I/O Signals .....	- 20 -
3.2.1 Examples of I/O Signal Connections .....	- 20 -
3.2.2 I/O Signal Names and Functions .....	- 21 -
3.2.3 I/O Signal Connector (CN1) Terminal Layout .....	- 23 -
3.2.4 Interface Circuit .....	- 24 -
3.3 Wiring Encoders .....	- 25 -
3.3.1 Connecting an Encoder(CN2) .....	- 25 -
3.3.2 Encoder Connector(CN2) Terminal Layout .....	- 26 -
3.4 Communication Connection .....	- 26 -
3.4.1 Communication Connector(CN3) Terminal Layout .....	- 26 -
3.4.2 Communication Connector(CN4) Terminal Layout .....	- 26 -
3.5 Standard Wiring Examples .....	- 27 -
3.5.1 Three-phase 200V(ProNet-E-02A~04A) .....	- 27 -

3.5.2 Three-phase 200V(ProNet-E-08A~50A) .....	- 28 -
3.5.3 Three-phase 400V(ProNet-E-10D~15D) .....	- 29 -
3.5.4 Position Control Mode .....	- 30 -
3.5.5 Speed Control Mode .....	- 31 -
3.5.6 Torque Control Mode .....	- 32 -
3.6 Wiring for Noise Control .....	- 33 -
3.6.1 Noise Control .....	- 33 -
3.6.2 Precautions on Connecting Noise Filter .....	- 34 -
3.7 Installation Conditions of EMC Directives .....	- 36 -
3.8 Using More than One Servo Drive .....	- 38 -
Chapter 4 .....	- 39 -
Operation .....	- 39 -
4.1 Trial Operation .....	- 39 -
4.1.1 Trial Operation for Servomotor Without Load .....	- 41 -
4.1.2 Trial Operation for Servomotor without Load from Host Reference .....	- 43 -
4.1.3 Trial Operation with the Servomotor Connected to the Machine .....	- 47 -
4.1.4 Trial Operation for Servomotor with Brakes .....	- 48 -
4.1.5 Position Control by Host Controller .....	- 48 -
4.2 Control Mode Selection .....	- 49 -
4.3 Setting Common Basic Functions .....	- 50 -
4.3.1 Setting the Servo ON Signal .....	- 50 -
4.3.2 Switching the Servomotor Rotation Direction .....	- 51 -
4.3.3 Setting the Overtravel Limit Function .....	- 52 -
4.3.4 Setting for Holding Brakes .....	- 55 -
4.3.5 Instantaneous Power Loss Settings .....	- 58 -
4.4 Operating Using Speed Control with Analog Reference .....	- 59 -
4.4.1 Setting Parameters .....	- 59 -
4.4.2 Setting Input Signals .....	- 60 -
4.4.3 Adjusting Reference Offset .....	- 61 -
4.4.4 Soft Start .....	- 64 -
4.4.5 Speed Reference Filter Time Constant .....	- 64 -
4.4.6 S-curve Risetime .....	- 65 -
4.4.7 Using the Zero Clamp Function .....	- 65 -
4.4.8 Encoder Signal Output .....	- 67 -
4.4.9 Speed coincidence output .....	- 68 -
4.5 Operating Using Position Control .....	- 69 -
4.5.1 Basic Setting in Position Control .....	- 69 -
4.5.2 Setting the Clear Signal .....	- 73 -
4.5.3 Setting the Electronic Gear .....	- 73 -
4.5.4 Smoothing .....	- 76 -
4.5.5 Low Frequency Vibration Suppression .....	- 77 -
4.5.6 Positioning Completion Output Signal .....	- 79 -
4.5.7 Reference Pulse Inhibit Function(INHIBIT) .....	- 80 -
4.5.8 Position Control (contact reference) .....	- 81 -
4.5.9 Position Homing Control (Homing Function) .....	- 84 -
4.6 Operating Using Torque Control .....	- 87 -

4.6.1	Setting Parameters .....	- 87 -
4.6.2	Torque Reference Input.....	- 88 -
4.6.3	Adjusting the Reference Offset .....	- 89 -
4.6.4	Limiting Servomotor Speed During Torque Control.....	- 90 -
4.7	Operating Using Speed Control with an Internally Set Speed .....	- 91 -
4.7.1	Setting Parameters .....	- 92 -
4.7.2	Input Signal Settings.....	- 93 -
4.7.3	Operating Using an Internally Set Speed.....	- 93 -
4.7.4	Limiting Servomotor Speed During Torque Control.....	- 94 -
4.8	Limiting Torque.....	- 95 -
4.8.1	Internal Torque Limit .....	- 95 -
4.8.2	External Torque Limit.....	- 96 -
4.8.3	Torque Limiting Using an Analog Voltage Reference .....	- 97 -
4.9	Control Mode Selection.....	- 98 -
4.9.1	Setting Parameters .....	- 98 -
4.9.2	Switching the Control Mode.....	- 98 -
4.10	Other Output Signals .....	- 99 -
4.10.1	Servo alarm output .....	- 99 -
4.10.2	Rotation Detection Output Signal(/TGON).....	- 100 -
4.10.3	Servo Ready(/S-RDY) Output.....	- 100 -
4.10.4	Encoder C Pluse Output (/PGC).....	- 100 -
4.10.5	Over travel signal output(OT) .....	- 101 -
4.10.6	Servo Enabled Motor Excitation Output(/RD) .....	- 101 -
4.10.7	Torque Limit Detection Output (/CLT) .....	- 101 -
4.11	Online Autotuning.....	- 103 -
4.11.1	Online Autotuning .....	- 103 -
4.11.2	Online Autotuning Procedure .....	- 103 -
4.11.3	Setting Online Autotuning .....	- 104 -
4.11.4	Machine Rigidity Setting for Online Autotuning .....	- 104 -
Chapter 5	.....	- 105 -
Panel Operator	.....	- 105 -
5.1	Basic Operation .....	- 105 -
5.1.1	Functions on Panel Operator.....	- 105 -
5.1.2	Resetting Servo Alarms .....	- 105 -
5.1.3	Basic Mode Selection .....	- 106 -
5.1.4	Status Display Mode .....	- 106 -
5.1.5	Operation in Parameter Setting Mode .....	- 108 -
5.1.6	Operation in Monitor Mode .....	- 109 -
5.2	Operation in Utility Function Mode.....	- 112 -
5.2.1	Alarm Traceback Data Display.....	- 112 -
5.2.2	Parameter Settings Initialization .....	- 113 -
5.2.3	Operation in JOG Mode.....	- 114 -
5.2.4	Automatic Adjustment of the Speed Reference Offset .....	- 115 -
5.2.5	Manual Adjustment of the Speed Reference Offset .....	- 116 -
5.2.6	Offset-adjustment of Servomotor Current Detection Signal .....	- 117 -
5.2.7	Software Version Display.....	- 119 -



5.2.8 Position Teaching Function.....	- 119 -
5.2.9 Static Inertia Detection.....	- 119 -
Chapter 6 .....	- 121 -
MODBUS Communication.....	- 121 -
6.1 RS-485 Communication Wiring.....	- 121 -
6.2 MODBUS Communication Related Parameters .....	- 122 -
6.3 MODBUS Communication Protocol .....	- 123 -
6.3.1 Code Meaning .....	- 123 -
6.3.2 Communication Error Disposal .....	- 129 -
6.3.3 Data Communication Address of Servo State.....	- 130 -
Chapter 7 .....	- 132 -
Specifications and Characters.....	- 132 -
7.1 Servodrive Specifications and Models .....	- 132 -
7.2 Servodrive Dimensional Drawings .....	- 134 -
Appendix A.....	- 136 -
Parameter .....	- 136 -
A.1 Parameter List .....	- 136 -
A.2 Description of Parameter Type .....	- 143 -
A.3 Parameters in detail.....	- 144 -
Appendix B.....	- 161 -
Alarm Display.....	- 161 -

## Checking Products and Parts Names

### 1.1 Checking Products on Delivery

Check Items	Comments
Are the delivered products the ones that were ordered?	Check the model numbers marked on the nameplate on the servomotor and servodrive.
Is there any damage?	Check the overall appearance, and check for damage or scratches that may have occurred during shipping.
Dose the servomotor shaft rotate smoothly?	If the servomotor shaft is smoothly turned by hand, it is normal. However, if the servomotor has brakes, it cannot be turned manually.

If any of the above items are faulty or incorrect, contact your ESTUN representative or the dealer from whom you purchased the products.

#### 1.1.1 Servomotor

##### ■ Servomotor Model Designation

**EMG-**                      **10**                      **A**                      **P**                      **A**                      **1**                      **1**  
 ESTUN Servomotor                      **【1+2】**                      **【3】**                      **【4】**                      **【5】**                      **【6】**                      **【7】**  
 EMG Model

##### 【1+2】 Rated Output

Code	Rated Output
10	1.0kW
15	1.5kW
20	2.0kW
30	3.0kW
50	5.0kW

##### 【4】 Encoder

Code	Encoder
P	Wire-saving Encoder: 2500P/R

##### 【7】 Option

Code	Option
1	None
2	With oil seal
3	With brake(DC 24V)
4	With oil seal and brake(DC 24V)

##### 【3】 Voltage

Code	Voltage
A	200V AC
D	400VAC

##### 【5】 Designing Sequence

Code	Designing Sequence
A	Designing sequence

##### 【6】 Shaft End

Code	Shaft End
1	Straight without key(Standard)
2	Straight with key and tap

##### Notes:

1. The EMG-30A□A□□, EMG-50A□A□□ servomotors are not mounted the incremental encoder.
2. There is no brake in EMG-□□□DA□□ servomotor.
3. EMG-10/15 servomotors add the supply voltage of 400V models.

## ■ Appearance and Nameplate

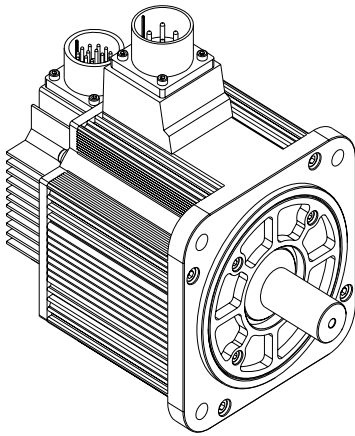

Servomotor model →

Ratings →

Serial number →

<b>ESTUN SERVOMOTOR</b>			
<b>MODEL EMG-20ADA22</b>			
2.0kW	9.55 N·m	2000 r/min	
12.0 A	200 V	CONT.	Ins.F
S/N: 5115334H019			
			
Estun Automation Technology Co.,Ltd Made in China			

## 1.1.2 Servodrive

### ■ Servodrive Model Designation

**PRONET-E - 10 A**

ProNet-E Model

**Voltage**  
A 200VAC  
D 400VAC

**Rated Output**  
02 0.2kW  
04 0.4 kW  
08 0.75 kW  
10 1.0 kW  
15 1.5 kW  
20 2.0 kW  
30 3.0 kW  
50 5.0 kW

### ■ Nameplate

Servodrive model →

Applicable power supply →

Serial number →

← Applicable servomotor capacity

<b>ESTUN SERVODRIVE</b>	
<b>MODEL PRONET-E-50A</b>	
<b>AC-INPUT</b>	<b>AC-OUTPUT</b>
3PH 200-230V 50/60Hz	3PH 0-200V 0-300Hz
22.4A	28.0A 5.0kW
S/N: 6600001J001	
	
CE	
Estun Automation Technology Co., Ltd. Made in China	

 切断电源 5 分钟内，请勿触摸驱动器端子和配线！有触电的危险。

**危险** 危险。  
WARNING Disconnect all power and wait 5 min. before servicing. May cause electric shock.

 注意 请勿触摸散热片！有烫伤危险。

**注意** 请勿触摸散热片！有烫伤危险。  
CAUTION Do not touch heatsink. May cause burn.

 接地端子必须接地。

Use proper grounding techniques.

■ Appearance

ProNet-E-02A~04A

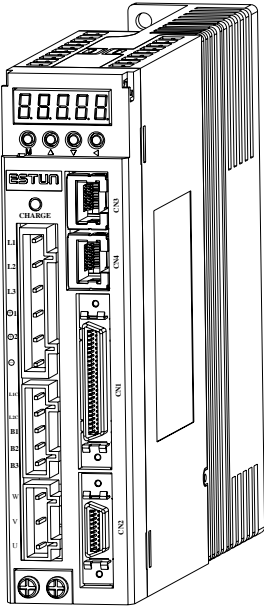

ProNet-E-08A~10A

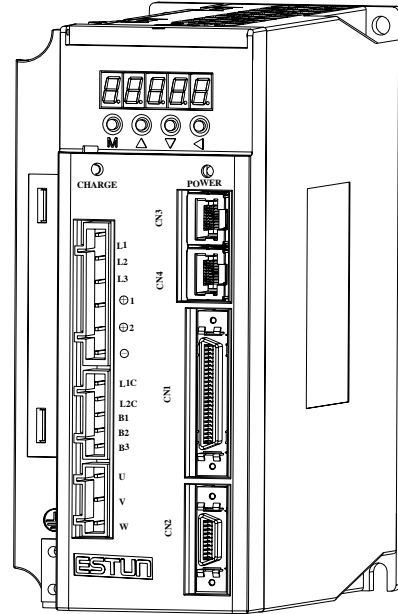

ProNet-E-10D/15A/15D

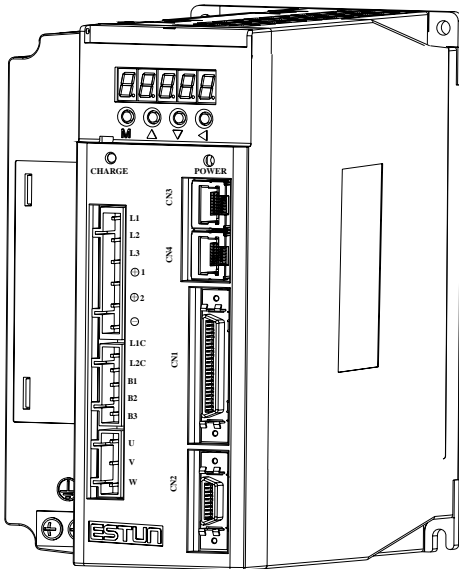

ProNet-E-20A~50A

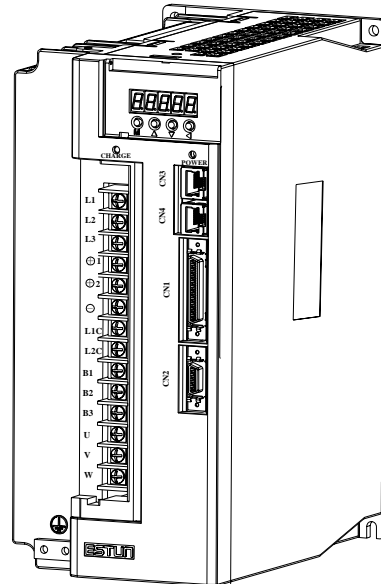

## 1.2 Part Names

### 1.2.1 Servomotor

Servomotor without gear and brake.

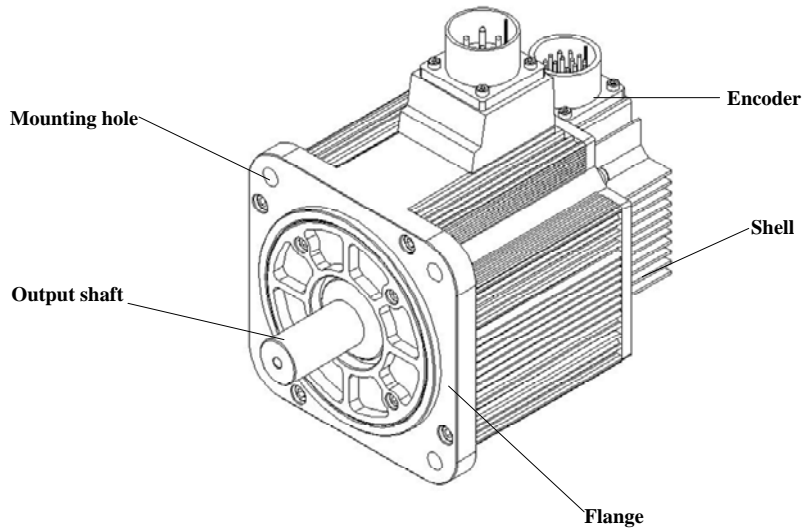

### 1.2.2 Servodrive

#### ■ ProNet-E-02A~04A

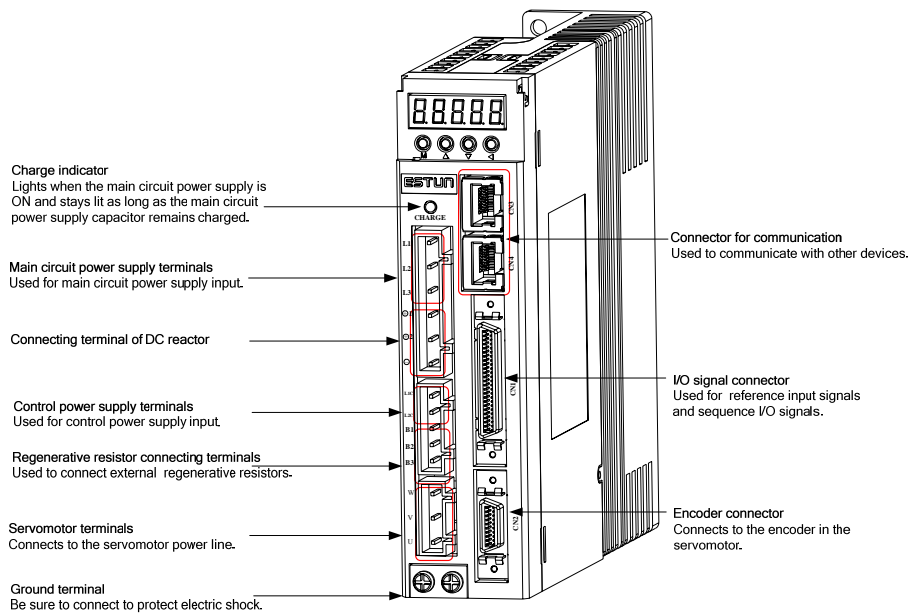

■ ProNet-E-08A~10A

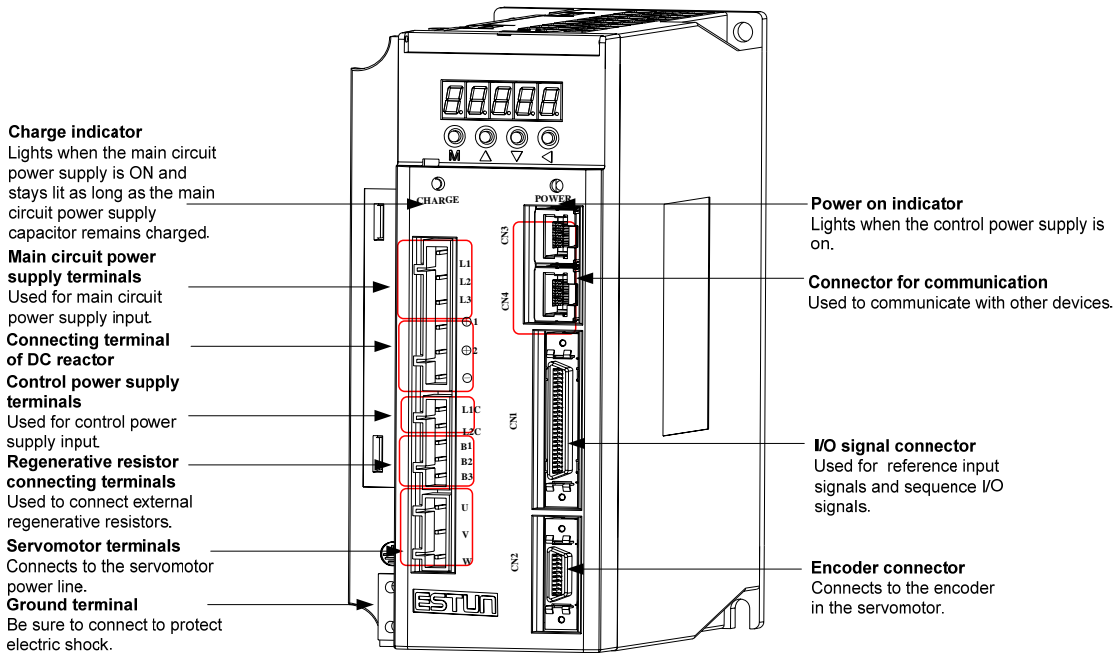

■ ProNet-E-10D/15A/15D

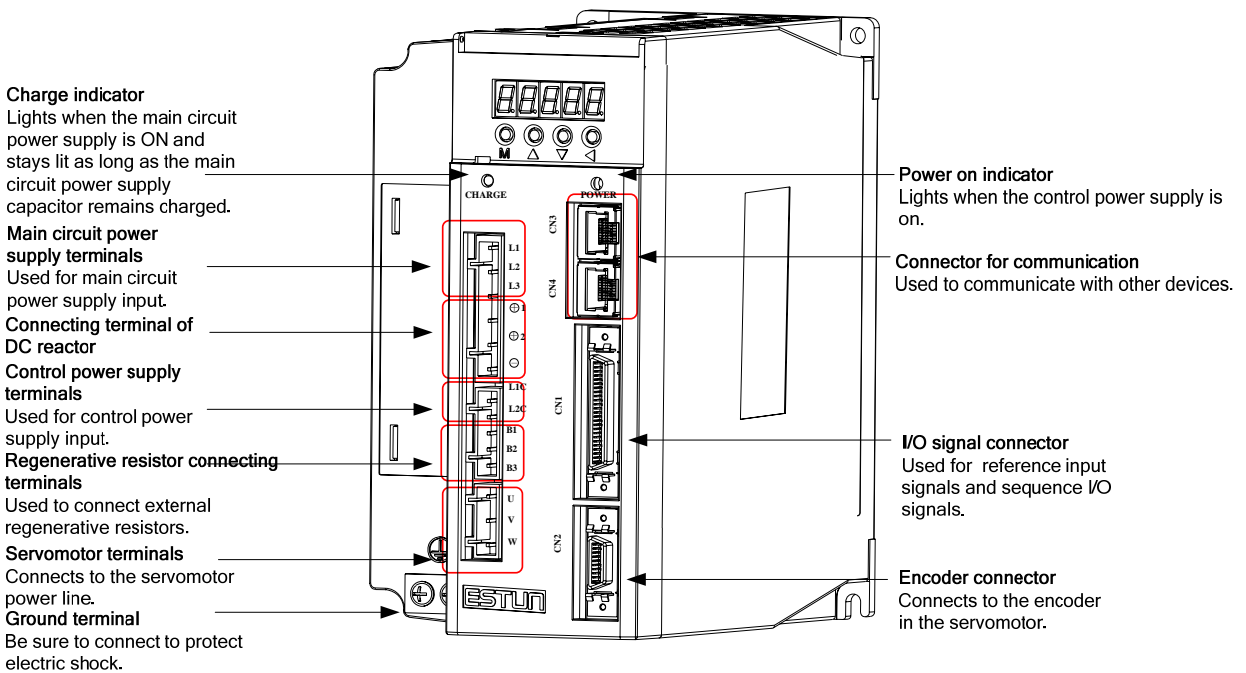

■ ProNet-E-20A~50A

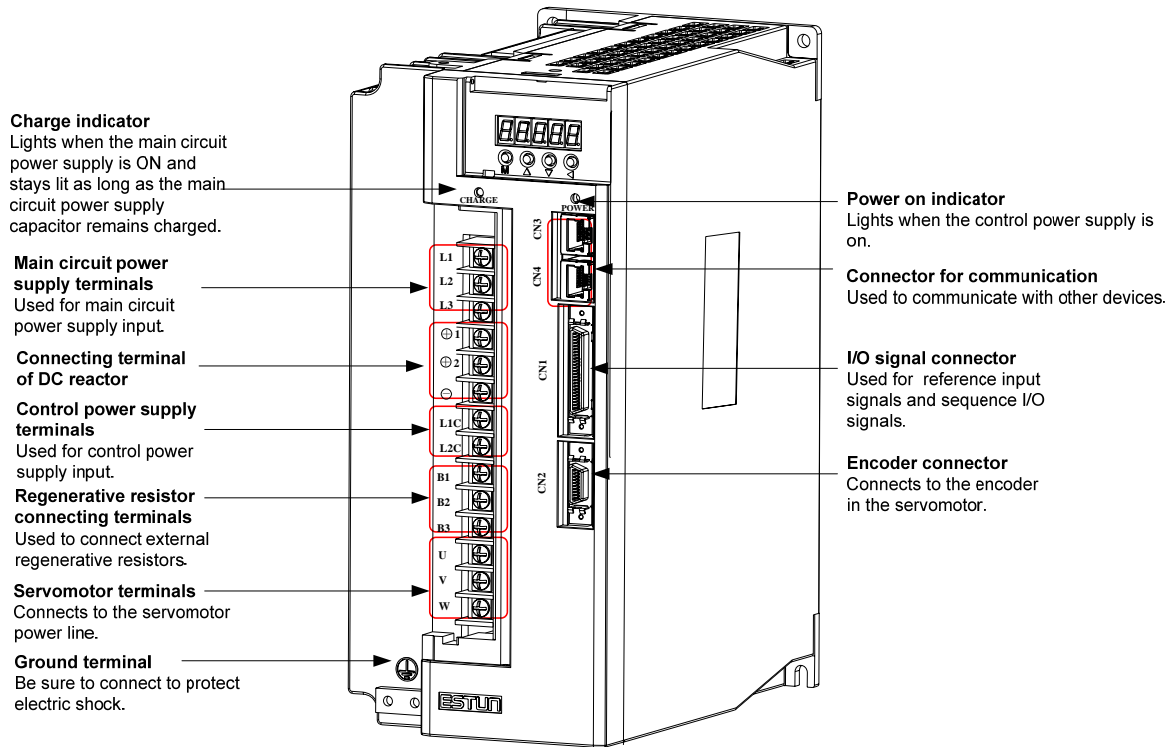

### 2.1 Servomotor

Servomotor can be installed either horizontally or vertically. However, if the servomotor is installed incorrectly, the service life of the servomotor will be shortened or unexpected problems will occur.

Please observe the installation instructions described below to install the servomotor correctly.

#### **Before installation:**

Anticorrosive paint is coated on the edge of the servomotor shaft. Clean off the anticorrosive paint thoroughly using a cloth moistened with thinner.

Avoid getting thinner on other parts of the servomotor when cleaning the shaft.

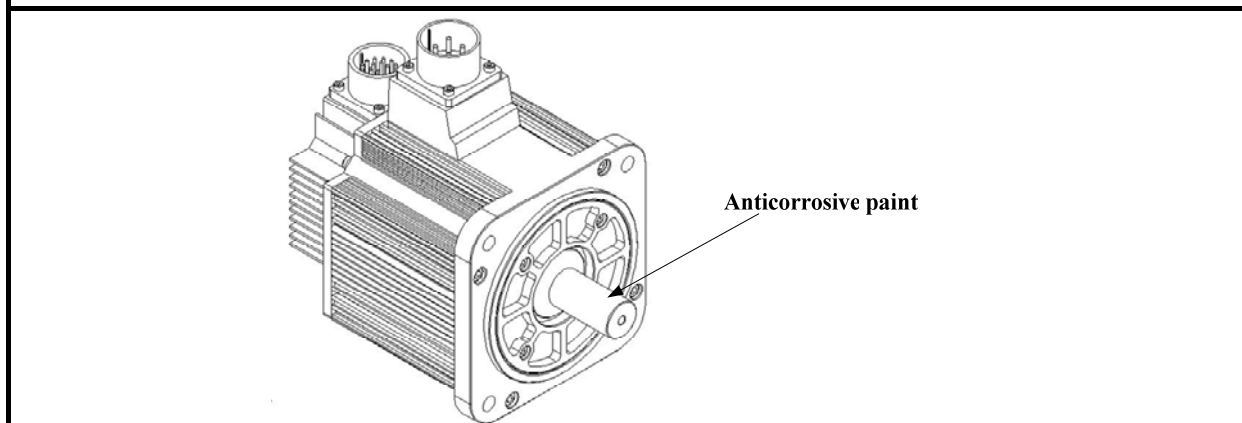

#### 2.1.1 Storage

When the servomotor is not used, store it in the temperature between  $-20^{\circ}\text{C}$  and  $60^{\circ}\text{C}$  with the power cable disconnected.

#### 2.1.2 Installation Sites

The servomotor is designed for indoor use. Install the servomotor in an environment which meets the following conditions.

- Free from corrosive and explosive gases.
- Well-ventilated and free from dust and moisture.
- Ambient temperature from  $0$  to  $40^{\circ}\text{C}$ .
- Relative humidity from 26% to 80% (non-condensing).
- Facilitates inspection and cleaning.



## 2.1.3 Installation Alignment

Align the shaft of the servomotor with that of the machinery to be controlled, and then connect the shafts with elastic couplings.

Install the servomotor so that alignment accuracy falls within the range shown below.

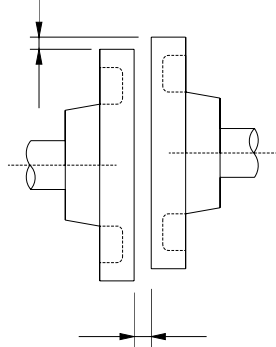

Measure this distance at four different positions in the circumference. The difference between the maximum and minimum measurements must be 0.03mm or less. (Turn together with couplings.)

---

**Note:**

- If the alignment accuracy is incorrect, vibration will occur, resulting in damage to the bearings.
  - Mechanical shock to the shaft end is forbidden, otherwise it may result in damage to the encoder of the servomotor.
- 

## 2.1.4 Installation Orientation

Servomotor can be installed either horizontally or vertically.

## 2.1.5 Handling Oil and Water

If the servomotor is used in a location that is subject to water or oil drops, make sure of the servomotor protective specification. If the servomotor is required to meet the protective specification to the through shaft section by default, use a servomotor with an oil seal.

**Through shaft section:**

It refers to the gap where the shaft protrudes from the end of the servomotor.

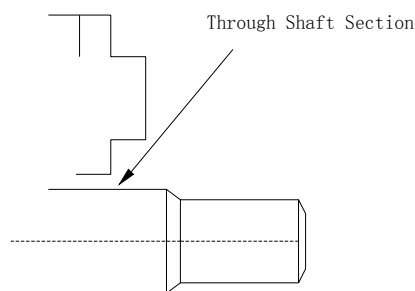

## 2.1.6 Cable Tension

When connecting the cables, the bending radius should not be too small, do not bend or apply tension to cables. Since the conductor of a signal cable is very thin (0.2 to 0.3 mm), handle it with adequate care.

## 2.2 Servodrive

ProNet-E series servodrive is a base-mounted type. Incorrect installation will cause problems. Always observe the installation instructions described below.

### 2.2.1 Storage

When the servodrive is not used, store it in the temperature between  $-20^{\circ}\text{C}$  and  $85^{\circ}\text{C}$  with the power cable disconnected.

### 2.2.2 Installation Sites

Notes on installation are shown below.

Situation	Notes on installation
When installed in a control panel	Design the control panel size, unit layout, and cooling method so that the temperature around the periphery of the servodrive does not exceed $55^{\circ}\text{C}$ .
When installed near a heating unit	Suppress radiation heat from the heating unit and a temperature rise caused by convection so that the temperature around the periphery of the servodrive does not exceed $55^{\circ}\text{C}$ .
When installed near a source of vibration	Install a vibration isolator underneath the servodrive to prevent it from receiving vibration.
When installed in a location subject to corrosive gases	Take appropriate action to prevent corrosive gases. Corrosive gases do not immediately affect the servodrive, but will eventually cause contactor-related devices to malfunction.
Others	Avoid installation in a hot and humid site or where excessive dust or iron powder is present in the air.

### 2.2.3 Installation Orientation

Install the servodrive perpendicular to the wall as shown in the figure. The servodrive must be oriented this way because it is designed to be cooled by natural convection or a cooling fan if required. Firmly secure the servodrive through two mounting holes.

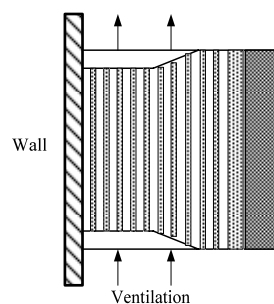

## 2.2.4 Installation Method

When installing multiple servodrives side by side in a control panel, observe the following installation method.

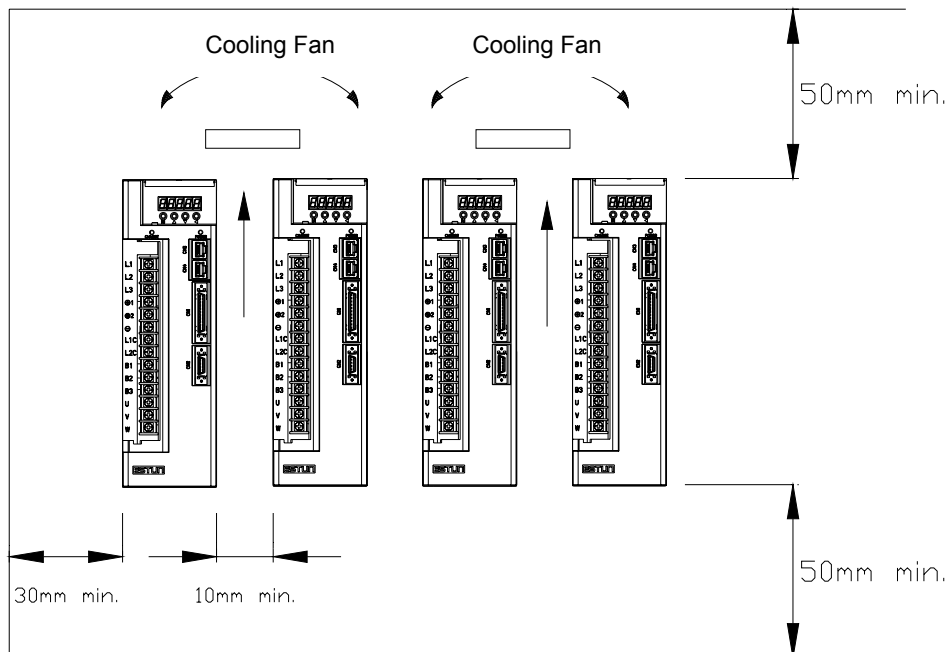

### ■ Installation Orientation

Install servodrive perpendicular to the wall so that the front panel (containing connectors) faces outward.

### ■ Cooling

Provide sufficient space around each servodrive to allow cooling by natural convection or fans.

### ■ Installing side by side

When installing servodrives side by side, provide at least 10 mm space between them and at least 50 mm space above and below them as shown in the figure above. Make sure that the temperature inside the control panel is evenly, and prevent the temperature around each servodrive from increasing excessively. Install cooling fans above the servodrives if required.

### ■ Working conditions

1. Temperature: 0~ 55°C
2. Humidity: 90%RH or less
3. Vibration: 4.9m/s<sup>2</sup> or less
4. Ambient temperature to ensure long-term reliability: 45°C or less

### 3.1 Main Circuit Wiring

Please observe the following instructions while wiring the main circuit.

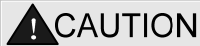
 CAUTION	
<ul style="list-style-type: none"> <li>• Do not bundle or run power and signal lines together in the same duct. Keep power and signal lines separated by at least 300 mm.</li> <li>• Use twisted-pair shielded wires or multi-core twisted-pair shielded wires for signal and encoder feedback lines.</li> <li>• The maximum length is 3 m for reference input lines and is 20 m for encoder feedback lines.</li> <li>• Do not touch the power terminals for 5 minutes after turning power OFF because high voltage may still remain in the servodrive.</li> </ul>	

#### 3.1.1 Names and Functions of Main Circuit Terminals

Terminal Symbol	Name	Main Circuit Voltage(V)	ProNet-E-	Functions
L1, L2, L3	Main circuit power supply input terminal	200	<input type="checkbox"/> □A	Three-phase 200~230VAC <sup>+10%</sup> <sub>-15%</sub> (50/60Hz)
		400	<input type="checkbox"/> □D	Three-phase 380~440VAC <sup>+10%</sup> <sub>-15%</sub> (50/60Hz)
U, V, W	Servomotor connection terminals	—	—	Connect to the servomotor.
L1C, L2C	Control circuit power supply input terminal	200	<input type="checkbox"/> □A	Single-phase 200~230VAC <sup>+10%</sup> <sub>-15%</sub> (50/60Hz)
		400	<input type="checkbox"/> □D	Single-phase 380~440VAC <sup>+10%</sup> <sub>-15%</sub> (50/60Hz)
	Ground terminals	—	—	Connects to the power supply ground terminals and servomotor ground terminal.
B1, B2, B3	External regenerative resistor connection terminal	200	02A—04A	Connect an external regenerative resistor(provided by customer) between B1 and B2.
			08A—50A	If use an internal regenerative resistor, please short B2 and B3. Remove the wire between B2 and B3 and connect an external regenerative resistor(provided by customer) between B1 and B2, if the capacity of the internal regenerative resistor is insufficient.
		400	10D—15D	
⊕1, ⊕2	DC reactor for harmonic	200	<input type="checkbox"/> □A	Normally short ⊕1 and ⊕2. If a countermeasure against power supply harmonic waves

Terminal Symbol	Name	Main Circuit Voltage(V)	ProNet-E-	Functions
	suppression terminal			is needed, connect a DC reactor between ⊕1 and ⊕2.
⊖	Main circuit minus terminal	200	□□A	Normally not connected.

### 3.1.2 Typical Main Circuit Wiring Examples

#### ■ Three-phase 200V ProNet-E-02A~04A

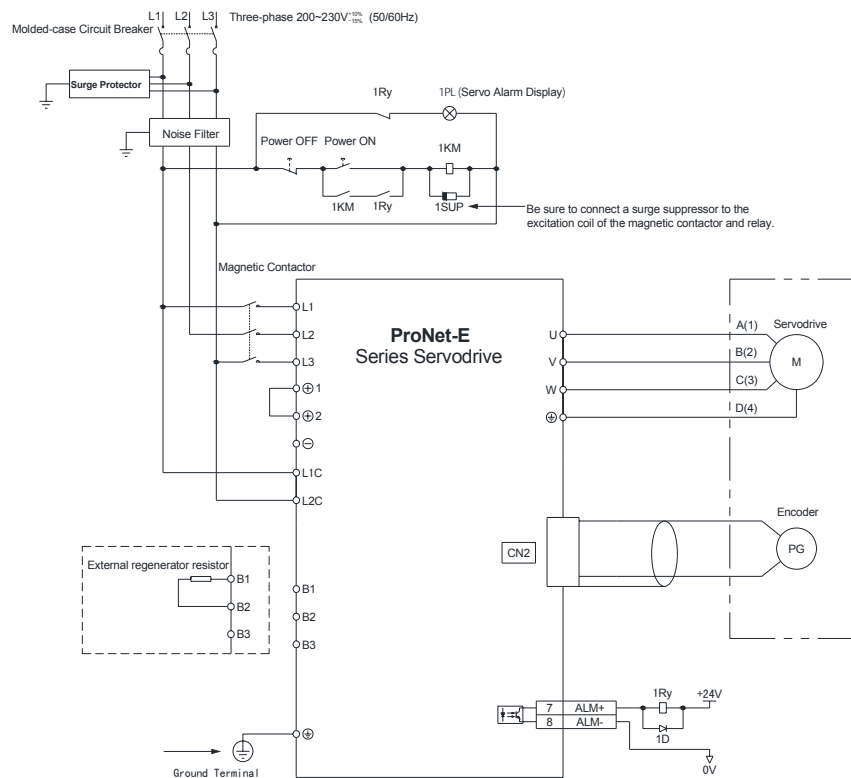

- Note 1. The L1,L2,L3 and L1C,L2C terminals wiring method of ProNet-E-02/04 servodrives is different from other ProNet-E series servodrives. Please note the specific terminal definition while wiring.
- External regenerative resistor for ProNet-E-02/04 is provided by customer, the model of ASQ60W50ΩKGO resistor is recommended.
  - ProNet-E-02/04 servo drives are also available for single-phase connection.
  - Change Pn521 from "1" to "0" when using the external regenerative resistor in ProNet-E-02/04 servo drives.

■ Three-phase 200V ProNet-E-08A~50A

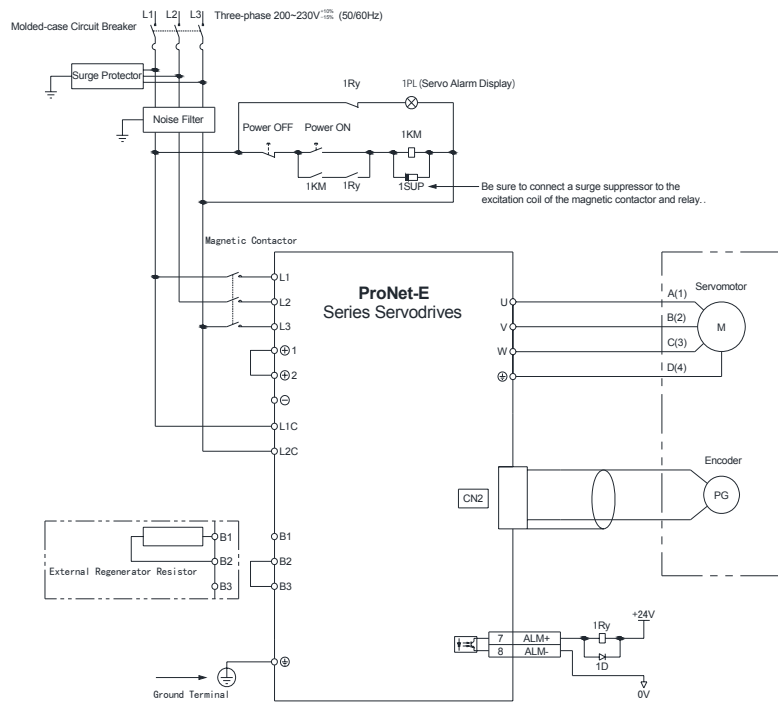

■ Three-phase 400V ProNet-E-10D~15D

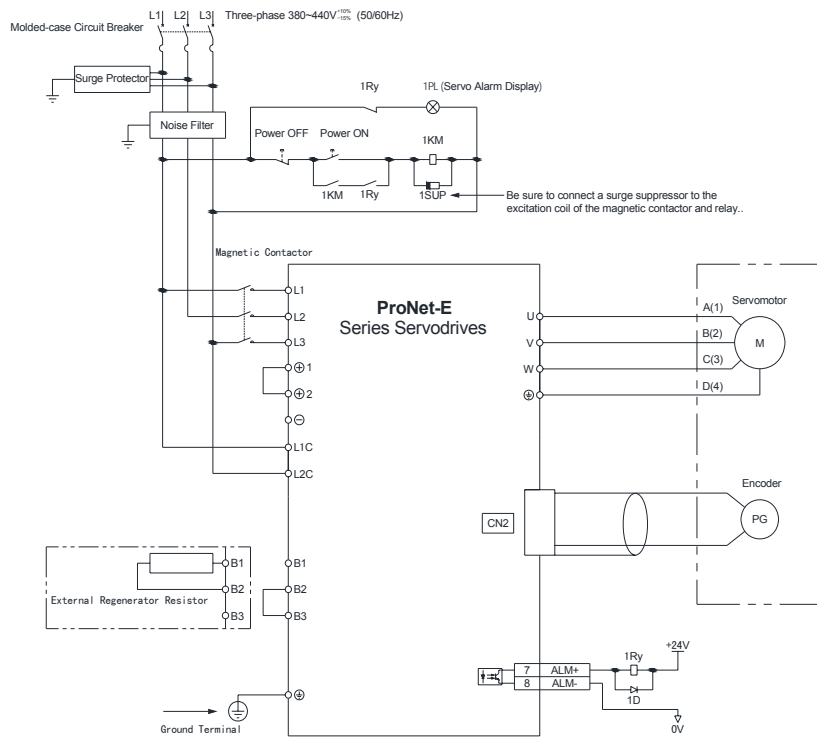

## 3.2 I/O Signals

### 3.2.1 Examples of I/O Signal Connections

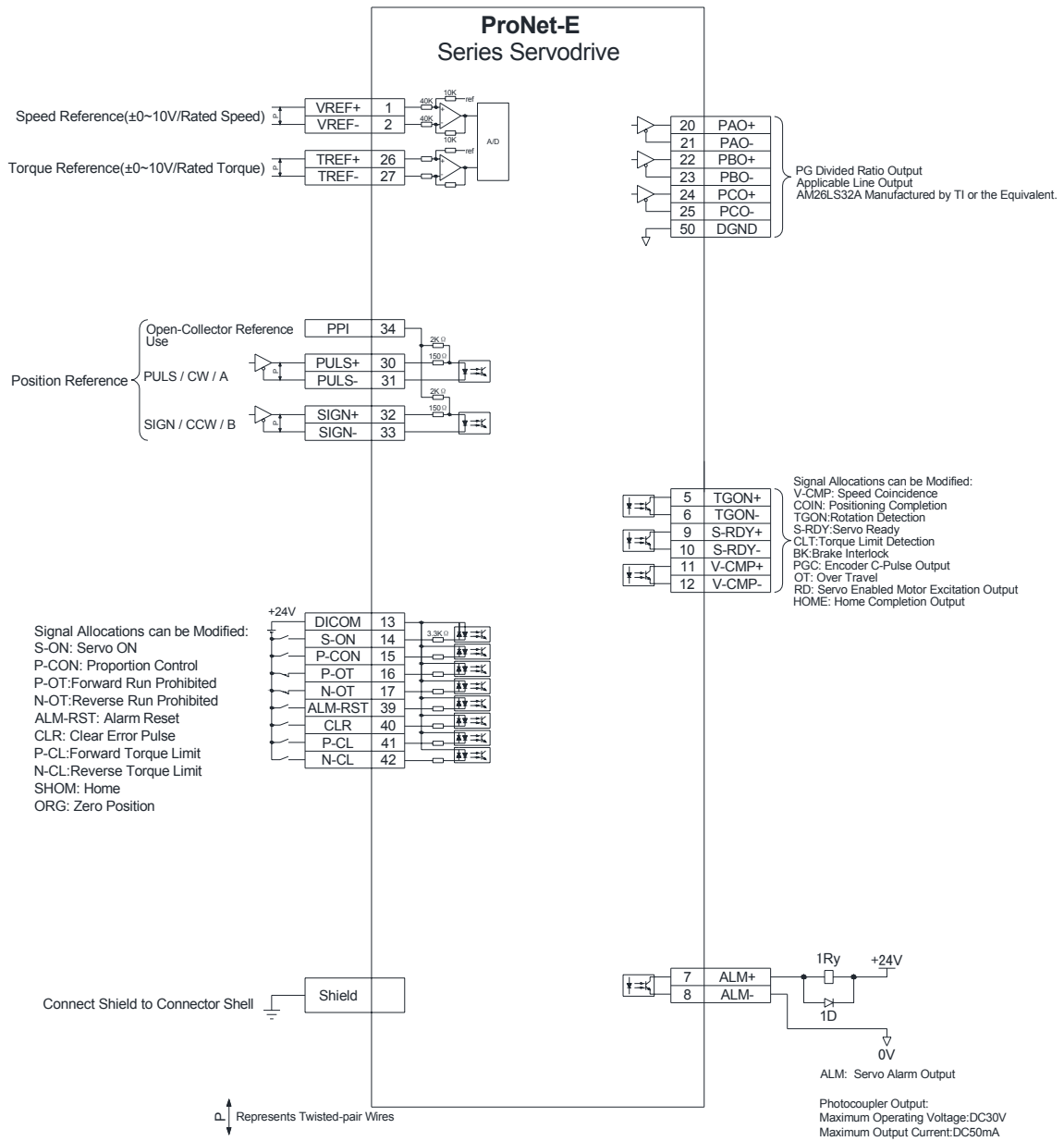

### 3.2.2 I/O Signal Names and Functions

#### ■ Input Signals

Control Mode	Signal Name	Pin No.	Function	
Speed Position Torque	/S-ON	14	Servo ON: Turns the servomotor on.	
	/P-CON	15	Function selected by parameter.	
			Proportional control reference	Switches the speed control loop from PI to P control when ON.
			Direction reference	With the internally set speed selection: Switch the rotation direction.
			Control mode switching	Enables control mode switching.
			Zero-clamp reference	Speed control with zero-clamp function: Reference speed is zero when ON.
			Reference pulse block	Position control with reference pulse: Stops reference pulse input when ON.
	P-OT N-OT	16 17	Forward run prohibited Reverse run prohibited	Overtravel prohibited: Stops servomotor when OFF.
	/PCL /NCL	41 42	Function selected by parameter.	
			Forward external torque limit ON Reverse external torque limit ON	Current limit function enabled when ON.
			Internal speed switching	With the internally set speed selection: Switches the internal speed settings.
/ALM-RST	39	Alarm reset: Releases the servo alarm state.		
DICOM	13	Control power supply input for I/O signals: Provide the +24V DC power supply		
Speed	VREF+	1	Speed reference input: ±10V.	
	VREF-	2		
Position	PULS+	30	Pulse reference input mode: Sign + pulse train CCW + CW pulse Two-phase pulse (90° phase differential)	
	PULS-	31		
	SIGN+	32		
	SIGN-	33		
	PPI	34	Power supply input for open collector reference (2KΩ/0.5W resistor is built into the servodrive).	
	/CLR	40	Positional error pulse clear input: Clear the positional error pulse during position control.	
	SHOM	-	Homing trigger signal(effective at the rising edge),allocated by Pn509 or Pn510	
	ORG	-	Zero Position(effective at high level), allocated by Pn509 or Pn510	
Torque	T-REF+	26	Torque reference input: ±10V.	
	T-REF-	27		



■ Output signals

Control Mode	Signal Name	Pin No.	Function	
Speed Position Torque	/TGON+	5	Detects when the servomotor is rotating at a speed higher than the motor speed setting.	
	/TGON-	6		
	ALM+	7	Servo alarm: Turns off when an error is detected.	
	ALM-	8		
	/S-RDY+	9	Servo ready: ON if there is no servo alarm when the control/main circuit power supply is turned ON.	
	/S-RDY-	10		
	PAO+	20	Phase-A signal	Converted two-phase pulse(phases A and B) encoder output.
	PAO-	21		
	PBO+	22	Phase-B signal	
	PBO-	23		
	PCO+	24	Phase-C signal	Zero-point pulse(Phase-C) signal
PCO-	25			
	FG	Shell	Connected to frame ground if the shield wire of the I/O signal cable is connected to the connector shell.	
Speed	/V-CMP+	11	Speed coincidence: Detects whether the motor speed is within the setting range and if it matches the reference speed value.	
	/V-CMP-	12		
Position	/COIN+	11	Positioning completion: Turns ON when the number of positional error pulses reaches the value set. The setting is the number of positional error pulses set in the reference units.	
	/COIN-	12		
Reserved	/CLT	—	Reserved terminals: The functions allocated to /TGON, /S-RDY, and /V-CMP (/COIN) can be changed by using the parameters. /CLT: Torque limit output Turns on when it reaches the value set.	
	/BK		/BK: Brake interlock output Releases the brake when ON, /PGC: C pulse output OT: Over travel signal output /RD: Servo enabled motor excitation output /HOME: Home completion output	
	—	4,18,19,29,35 36,37,38,43 44,45,47,49	Not used.	

### 3.2.3 I/O Signal Connector (CN1) Terminal Layout

Terminal No.	Name	Function		Terminal No.	Name	Function
1	VREF+	Speed reference input:±10V		26	T-REF+	Torque reference input:±10V
2	VREF-			27	T-REF-	
3	DGND	DGND		28	DGND	DGND
4	—	Reserved		29	—	Reserved
5	/TGON+	Running signal output		30	PULS+	Reference pulse input
6	/TGON-			31	PULS-	
7	ALM+	Servo alarm		32	SIGN+	Reference sign input
8	ALM-			33	SIGN-	
9	/S-RDY+	Servo ready		34	PPI	Open collector reference power supply
10	/S-RDY-			35	—	Reserved
11	/COIN+	Positioning completion		36	—	Reserved
12	/COIN-			37	—	Reserved
13	DICOM	I/O signal power supply 24V DC		38	—	Reserved
14	/S-ON	Servo ON		39	/ALM-RST	Alarm reset
15	/P-CON	P/PI control input		40	/CLR	Position error pulse clear input
16	P-OT	Forward run prohibit input		41	/PCL	Forward torque limit input
17	N-OT	Reverse run prohibit run		42	/NCL	Reverse torque limit input
18	—	Reserved		43	—	Reserved
19	—	Reserved		44	—	Reserved
20	PAO+	PG dividing pulse output phase A	PG dividing pulse output	45	—	Reserved
21	PAO-			46	DGND	DGND
22	PBO+	PG dividing pulse output phase B		47	—	Reserved
23	PBO-		48	DGND	DGND	
24	PCO+	PG dividing pulse output phase C	Zero-point pulse	49	—	Reserved
25	PCO-			50	DGND	DGND

**Note:** The functions allocated to the following input and output signals can be changed by using the parameters.

- Input signals: /S-ON,/P-CON,P-OT,N-OT,/ALM-RST,/CLR,/PCL,/NCL,SHOM,ORG
- Output signals: /TGON,/S-RDY,/COIN,/HOME

Please refer to **A.3 Parameters in details** for detailed information.

## 3.2.4 Interface Circuit

This section shows examples of servodrive I/O signal connection to the host controller.

### ■ Interface for Analog Reference Input Circuit

Analog signals are either speed or torque reference signals at about 40kΩ impedance, and the maximum allowable voltages for input signals is ±10V.

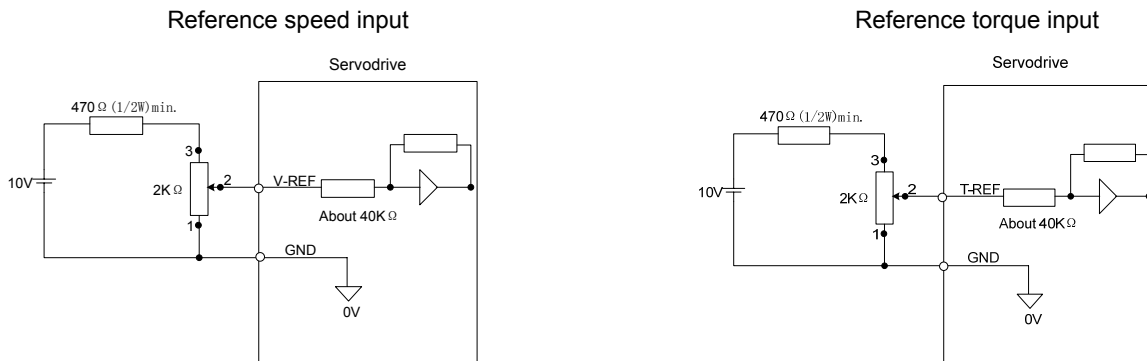

### ■ Interface for sequence input circuit

The sequence input circuit interface connects through a relay or open-collector transistor circuit. Select a low-current relay otherwise a faulty contact will result.

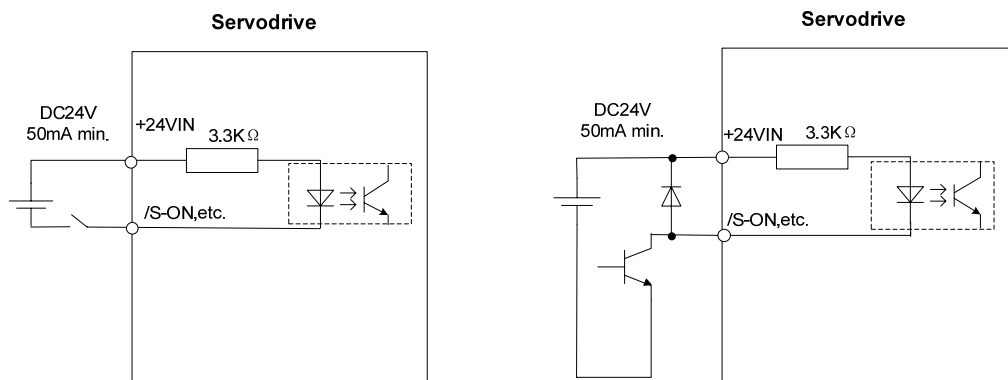

### ■ Interface for line driver output circuit

The amount of two-phase (phase A and phase B) pulse output signals (PAO,/PAO,PBO,/PBO) and zero-point pulse signals(PCO,/PCO) are output via line-driver output circuits. Normally, the servodrive uses this output circuit in speed control to comprise the position control system at the host controller. Connect the line-driver output circuit through a line receiver circuit at the host controller.

### ■ Interface for sequence output circuit

Photocoupler output circuits are used for Servo Alarm (ALM), Servo Ready(S-RDY), and other sequence output signal circuits. Connect a photocoupler output circuit through a relay circuit.

### 3.3 Wiring Encoders

#### 3.3.1 Connecting an Encoder(CN2)

■ Incremental wire-saving encoder (2500P/R) (water-proof)

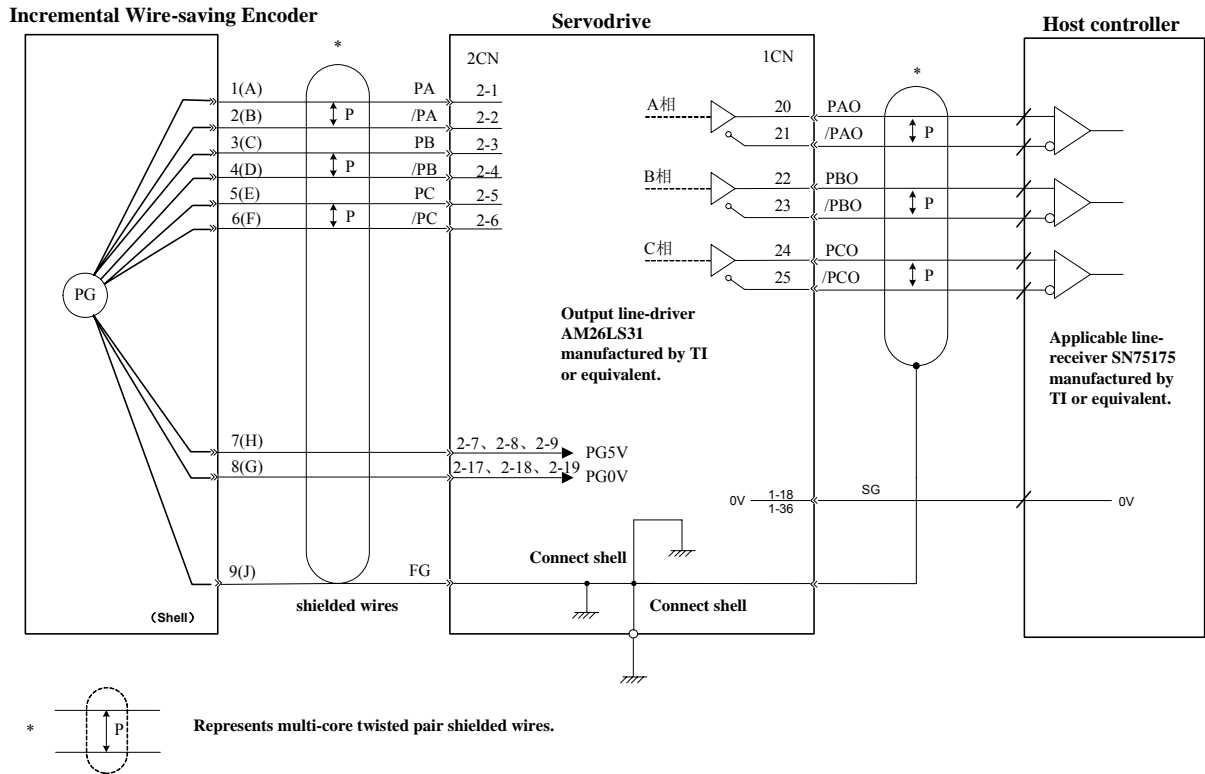

■ Incremental wire-saving encoder (2500P/R) (common)

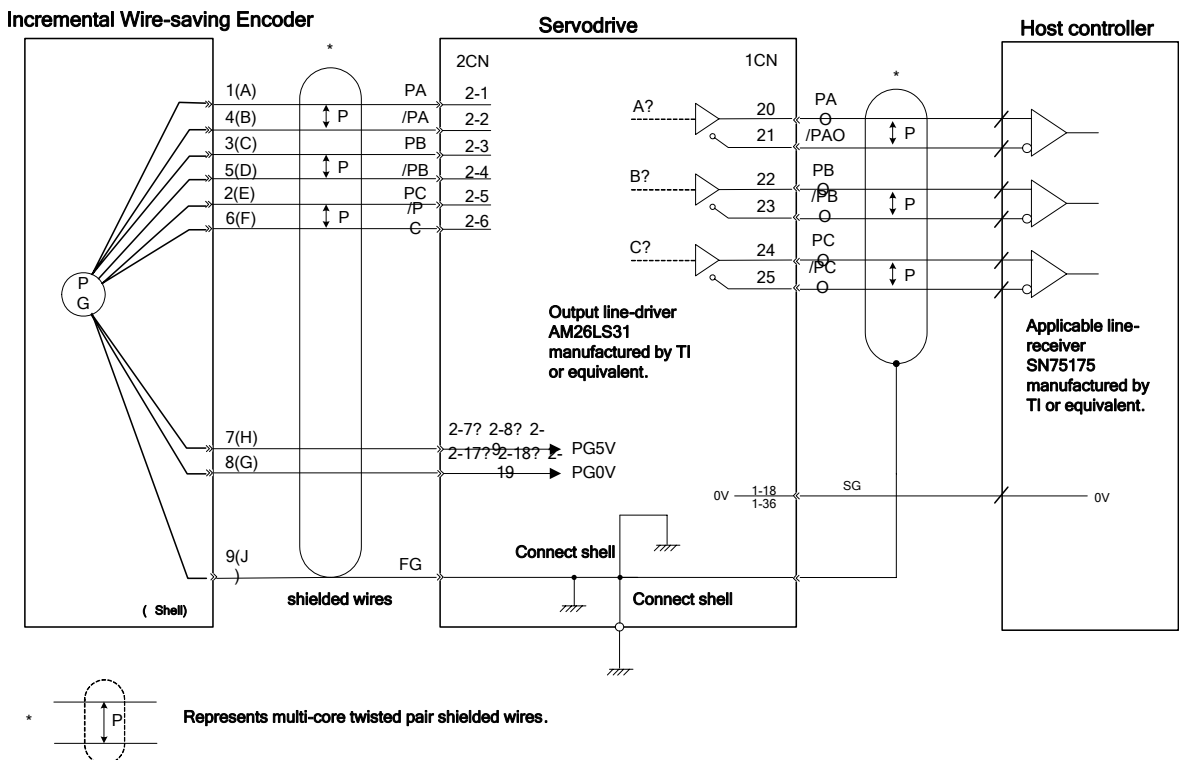

### 3.3.2 Encoder Connector(CN2) Terminal Layout

Terminal No.	Name	Function	Terminal No.	Name	Function
1	PA	PG input phase A	5	PC	PG input phase C
2	/PA	PG input phase/A	6	/PC	PG input phase/C
3	PB	PG input phase B	7,8,9	PG5V	PG power suppl +5V
4	/PB	PG input phase/B	17,18,19	SG	PG power suppl 0V

## 3.4 Communication Connection

### 3.4.1 Communication Connector(CN3) Terminal Layout

Terminal No.	Name	Function
1	—	Reserved
2	—	
3	485+	RS-485 communication terminal
4	ISO_GND	Isolated ground
5	ISO_GND	
6	485-	RS-485 communication terminal
7	CANH	CAN communication terminal
8	CANL	CAN communication terminal

Note: Do not short terminal 1 and 2 of CN3.

### 3.4.2 Communication Connector(CN4) Terminal Layout

Terminal No.	Name	Function
1	—	Reserved
2	—	
3	485+	RS-485 communication terminal
4	ISO_GND	Isolated ground
5	ISO_GND	
6	485-	RS-485 communication terminal
7	CANH	CAN communication terminal
8	CANL	CAN communication terminal

# 3.5 Standard Wiring Examples

## 3.5.1 Three-phase 200V(ProNet-E-02A~04A)

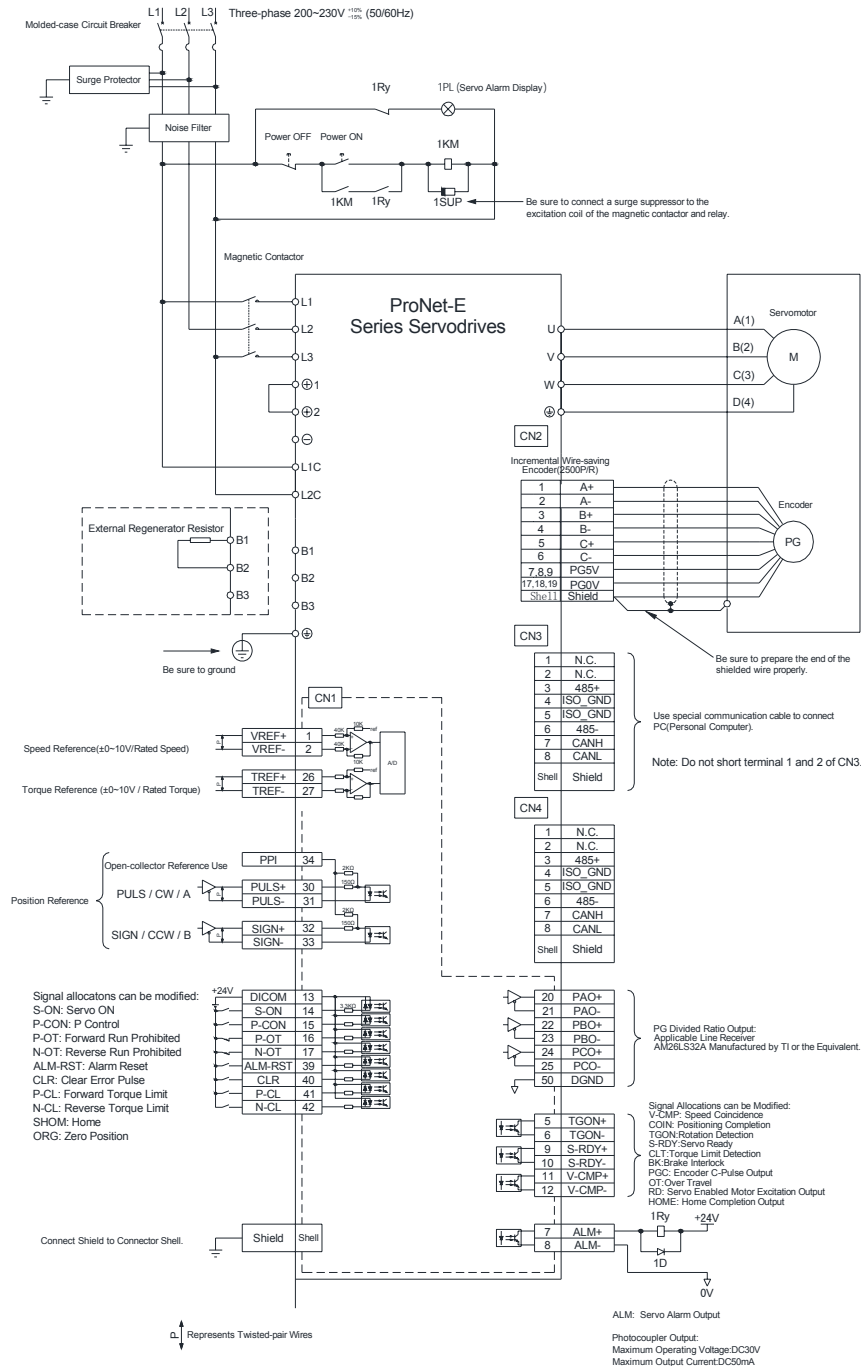

- Note 1. The L1,L2,L3 and L1C,L2C terminals wiring method of ProNet-E-02/04 servodrives is different from other ProNet-E series servodrives. Please note the specific terminal definition while wiring.
2. External regenerative resistor for ProNet-E-02/04 is provided by customer, the model of ASQ60W50ΩKGO resistor is recommended.
3. ProNet-E-02/04 servo drives are also available for single-phase connection.
4. Change Pn521 from "1" to "0" when using the external regenerative resistor in ProNet-E-02/04 servo drives.

### 3.5.2 Three-phase 200V(ProNet-E-08A~50A)

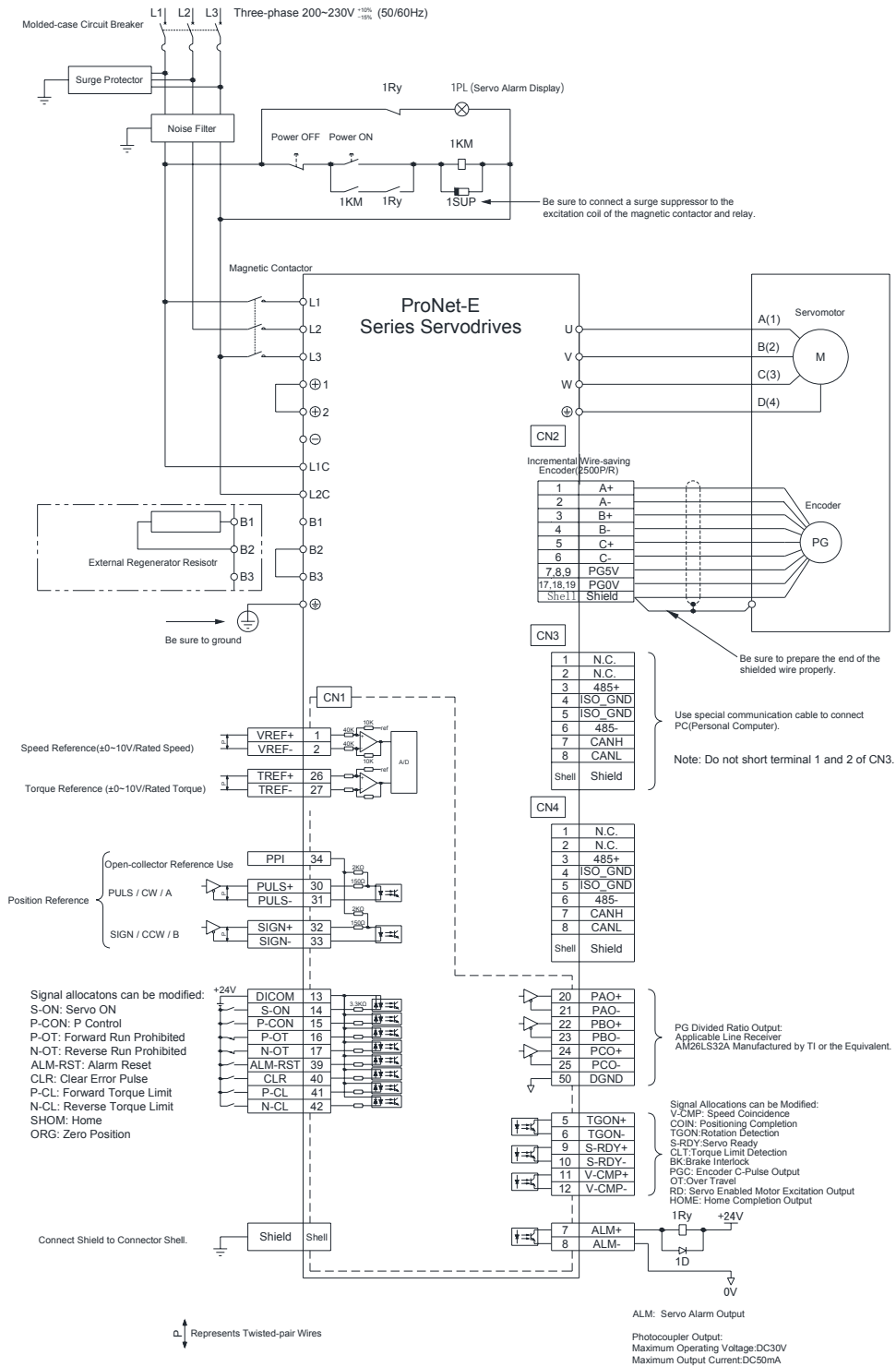

### 3.5.3 Three-phase 400V(ProNet-E-10D~15D)

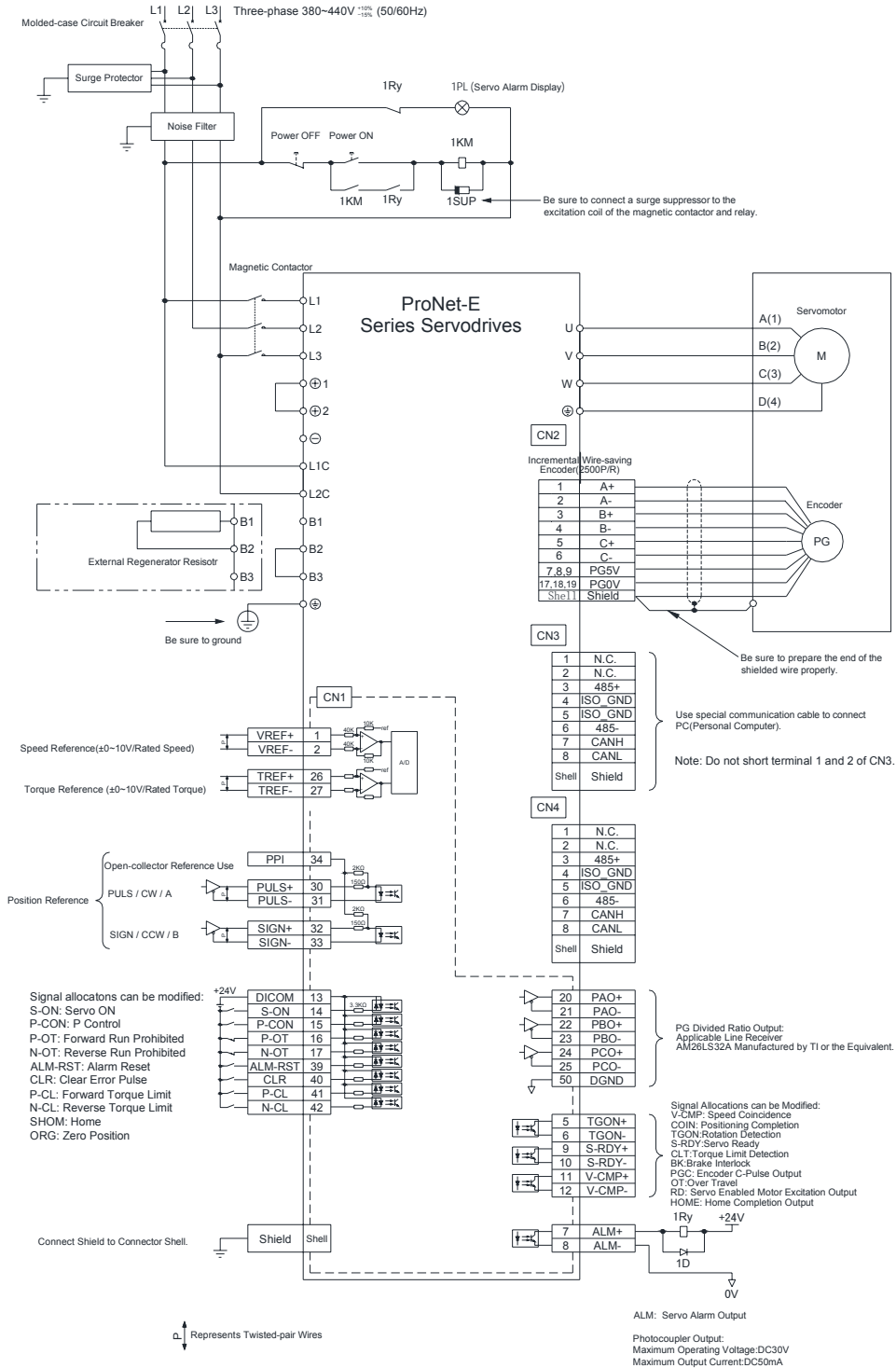



### 3.5.4 Position Control Mode

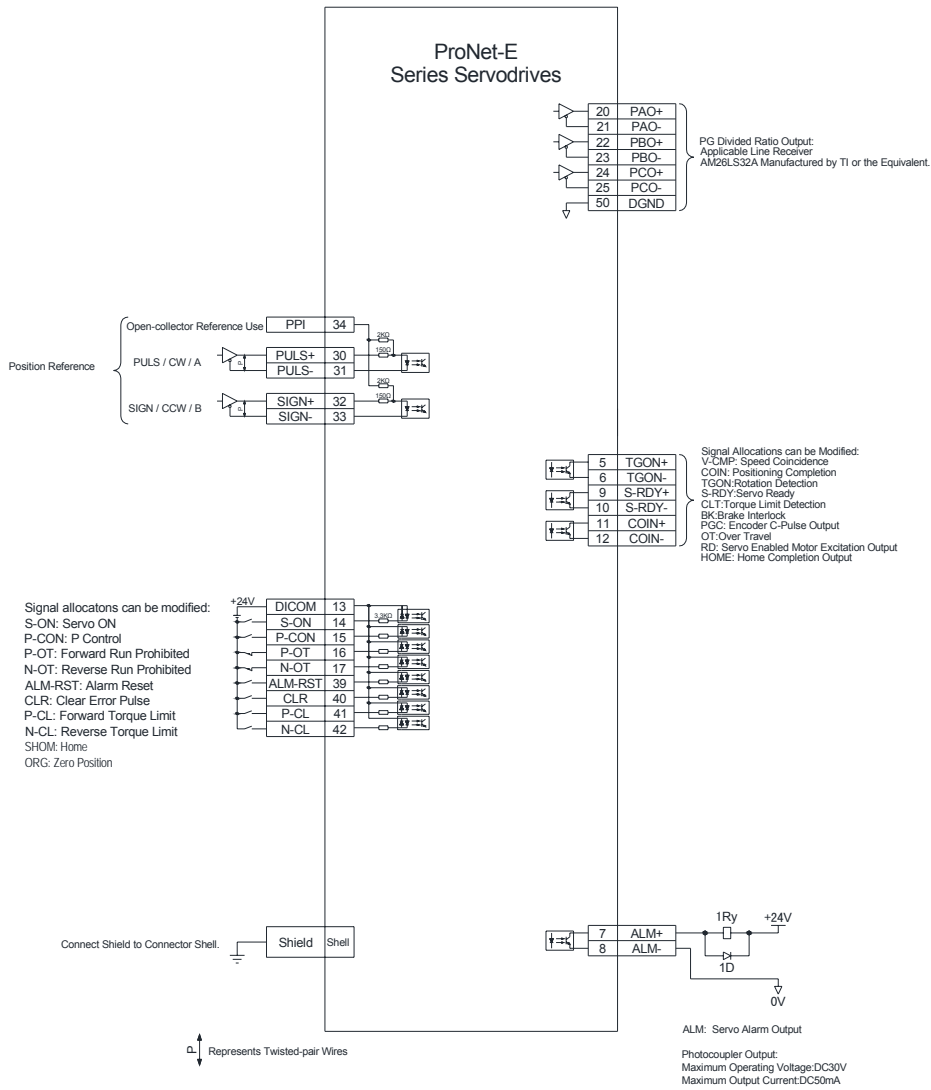

### 3.5.5 Speed Control Mode

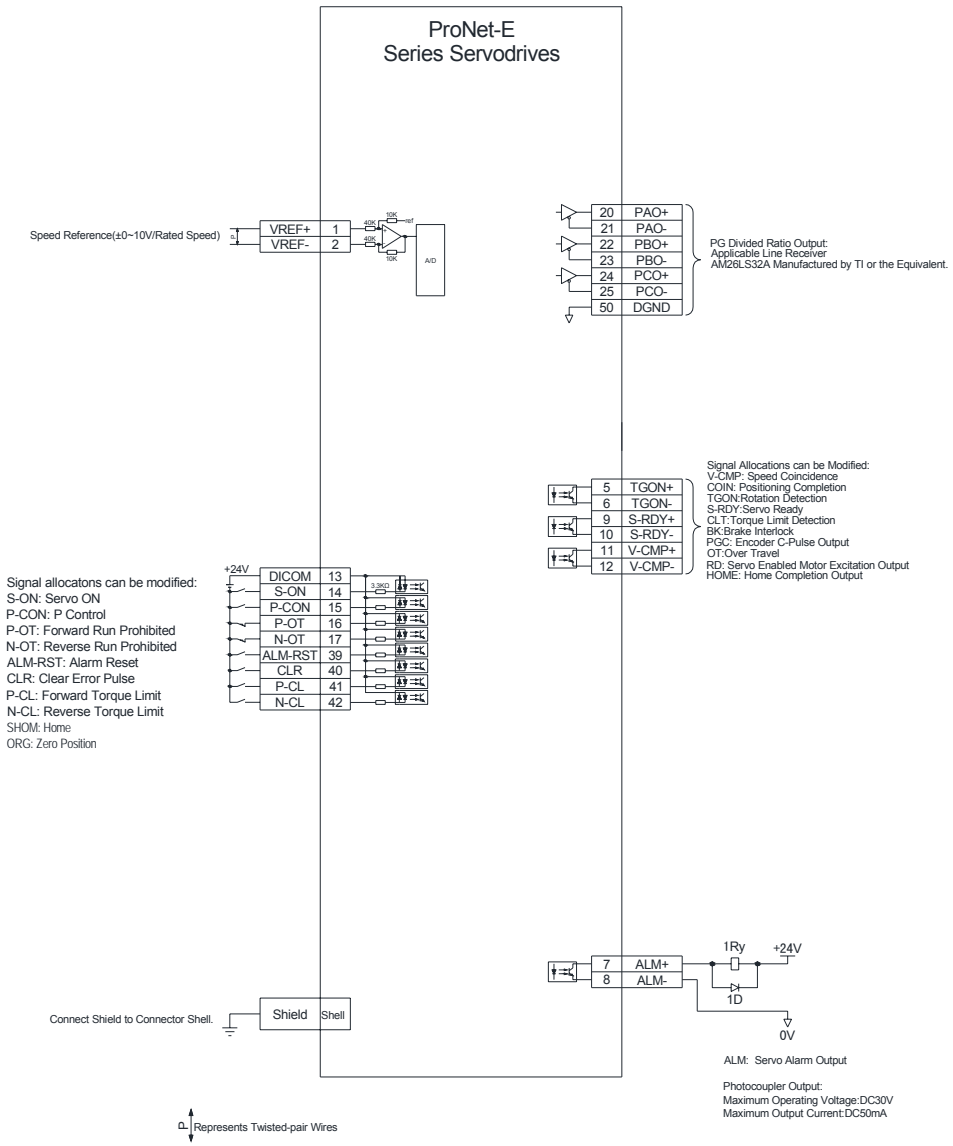

### 3.5.6 Torque Control Mode

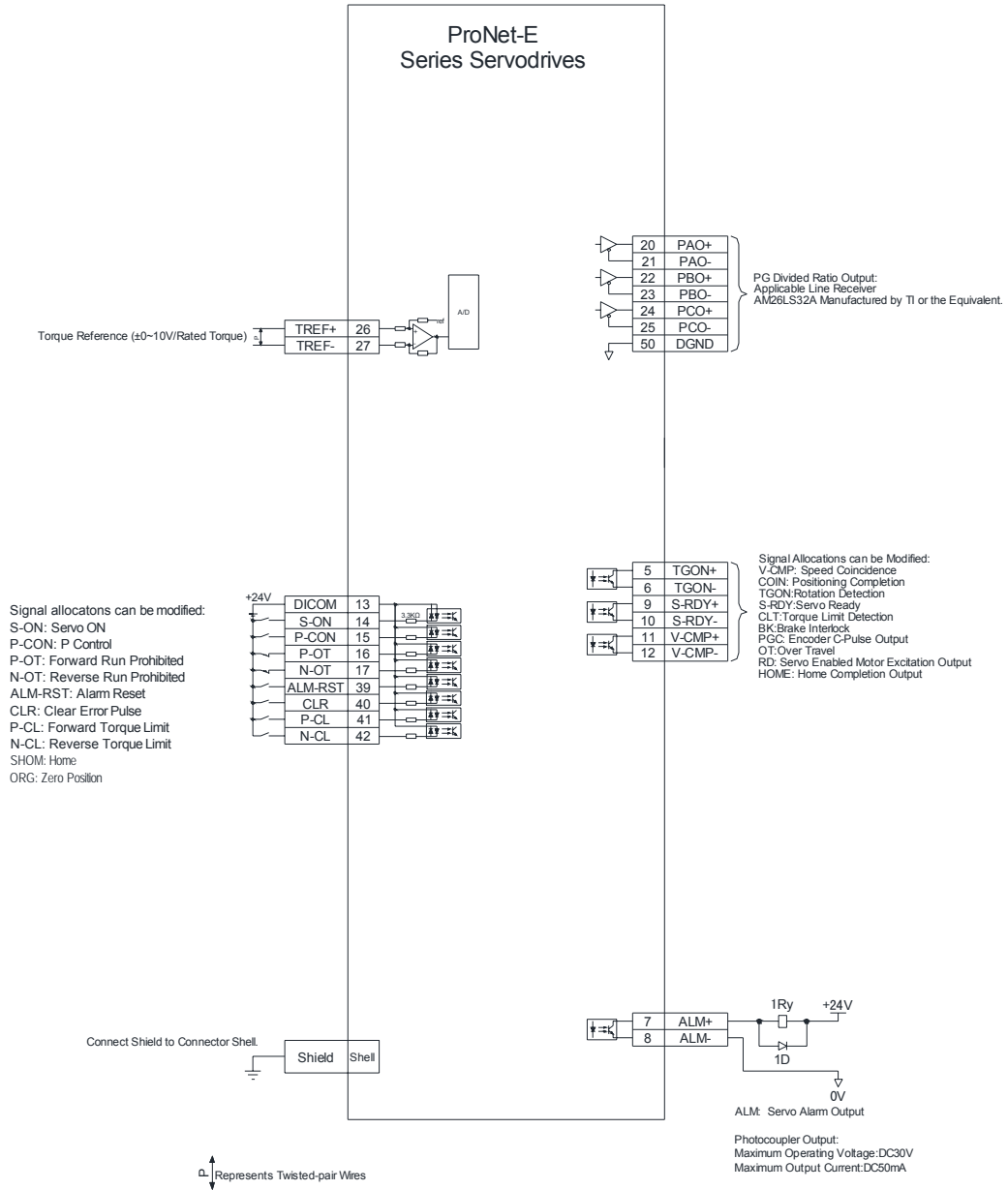

## 3.6 Wiring for Noise Control

### 3.6.1 Noise Control

The servo drive uses high-speed switching elements in the main circuit. It may receive "switching noise" from these high-speed switching elements.

To prevent malfunction due to noise, take the following actions:

- Position the input reference device and noise filter as close to the servo drive as possible.
- Always install a surge absorber in the relay, solenoid and electromagnetic contactor coils.
- The distance between a power line (servomotor main circuit cable) and a signal line must be at least 30 cm. Do not put the power and signal lines in the same duct or bundle them together.
- Do not share the power supply with an electric welder or electrical discharge machine. When the servo drive is placed near a high-frequency generator, install a noise filter on the input side of the power supply line. As for the wiring of noise filter, refer to **(1) Noise Filter** shown below.
- Take the grounding measures correctly. As for the grounding, refer to **(2) Correct Grounding**.

#### (1) Noise Filter

Please installing a noise filter in the appropriate place to protect servo drive from external noise as much as possible.

Notice:

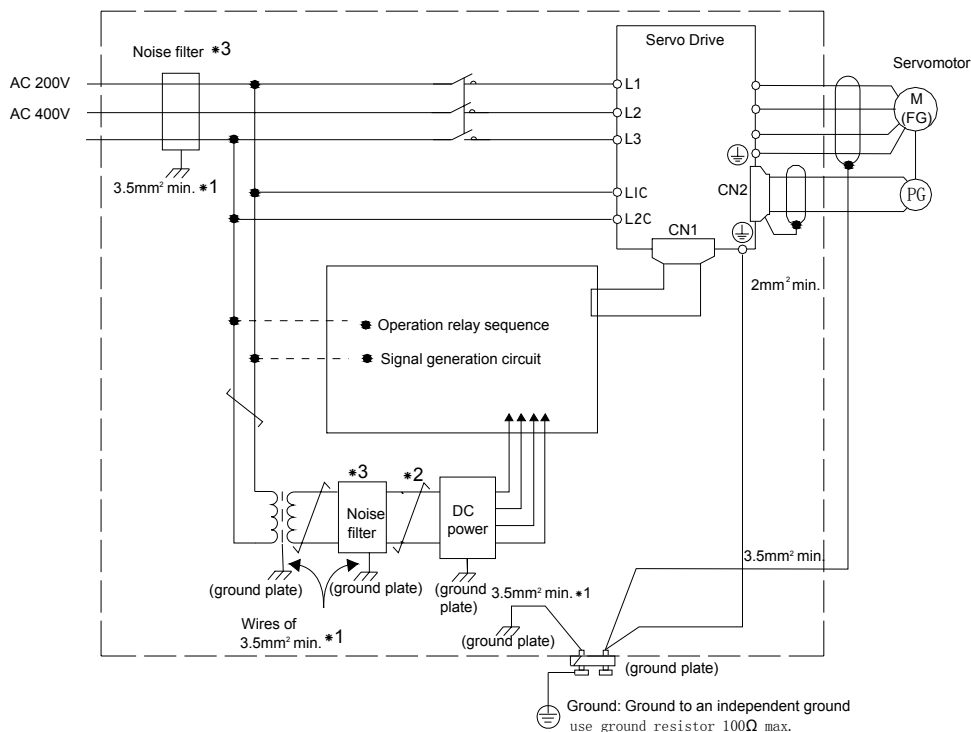

•For ground wires connected to the ground plate, use a thick wire with a thickness of at least 3.5 mm<sup>2</sup> (preferably, plain stitch cooper wire)

•  should be twisted-pair wires.

•When using a noise filter, follow the precautions in **3.6.2 Precautions on Connecting Noise Filter**.

## (2) Correct Grounding

Take the following grounding measures to prevent the malfunction due to noise.

### ■ Grounding the Motor Frame

If the servomotor is grounded via the machine, a switching noise current will flow from the servo drive main circuit through servomotor stray capacitance.

Always connect servomotor frame terminal FG to the servo drive ground terminal. Also be sure to ground the ground terminal .

### ■ Noise on the I/O Signal Line

If the I/O signal line receives noise, ground the 0 V line (SG) of the reference input line. If the main circuit wiring for the motor is accommodated in a metal conduit, ground the conduit and its junction box. For all grounding, ground at one point only.

## (3) Precautions on installing on control panel

■ When the servo drive installing on control panel, a piece of metal plate should be fixed. It is used for fixing the servo drive and other peripheral devices. Noise filter should be installed on metal plate, and closed to the hole drill through power lines on control panel. Use screws to fix the noise filter to the metal plate. The grounding terminals of noise filter connect to the grounding terminals of control panel.

■ Servo drive should be fixed on a piece of metal plate. Make sure the heat sink towards ground. The grounding terminals of servo drive connect to the grounding terminals of control panel.

## 3.6.2 Precautions on Connecting Noise Filter

### (1) Noise Filter Brake Power Supply

Use the noise filter Manufactured by SCHAFFNER at the brake power input for servomotors with holding brakes.

### (2) Precautions on Using Noise Filters

Do not put the input and output lines in the same duct or bundle them together.

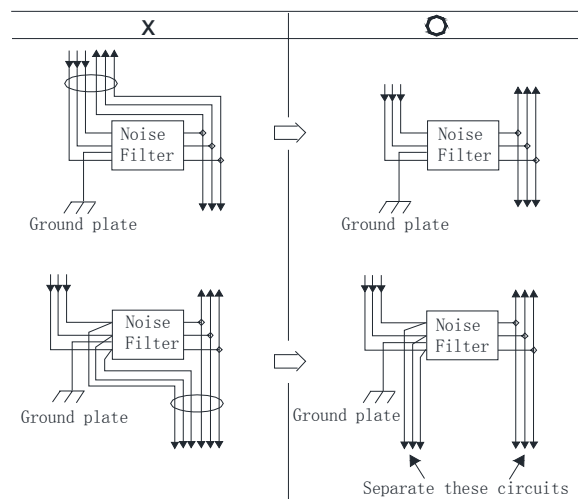

Separate the noise filter ground wire from the output lines.

Do not accommodate the noise filter ground wire, output lines and other signal lines in the same duct or bundle them together.

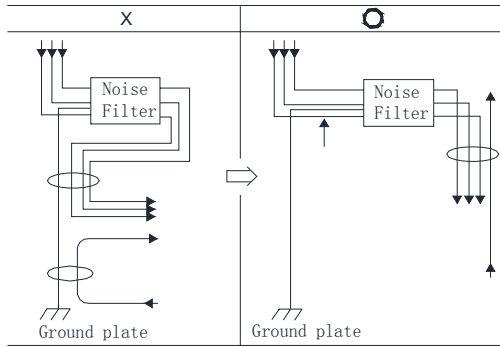

Connect the noise filter ground wire directly to the ground plate. Do not connect the noise filter ground wire to other ground wires.

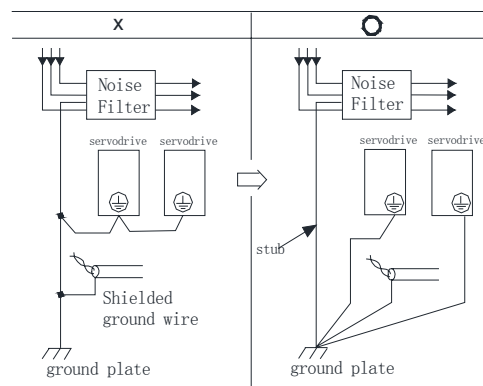

If a noise filter is located inside a control panel, connect the noise filter ground wire and the ground wires from other devices inside the control panel to the ground plate for the control panel first, then ground these wires.

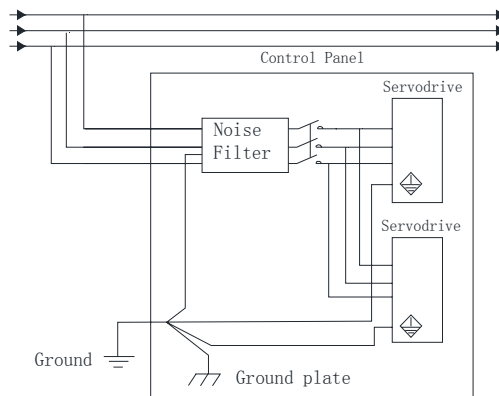

### 3.7 Installation Conditions of EMC Directives

To adapt a combination of a servomotor and a servodrive to EMC Directives (EN61326-1:2006), the following conditions must be satisfied.

#### (1) EMC Installation Conditions

This section describes the installation conditions that satisfy EMC guidelines for each model of the servodrive.

This section describes the EMC installation conditions satisfied in test conditions prepared by ESTUN. The actual EMC level may differ depending on the actual system's configuration, wiring, and other conditions.

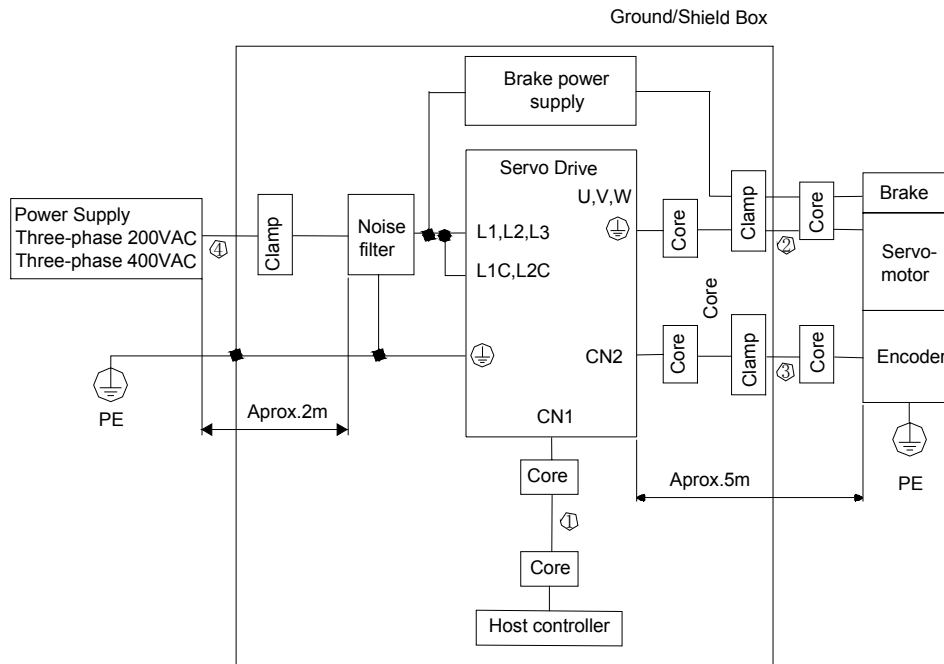

Symbol	Cable Name	Specifications
①	I/O signal cable	Shield cable
②	Servomotor cable	Shield cable
③	Encoder cable	Shield cable
④	AC line cable	Shield cable

#### (2) Cable Core and Cable Clamp

##### (a) Attaching the Ferrite Core

The diagram shows two turns in the cable.

The table shows the cable and the position where the ferrite core is attached.

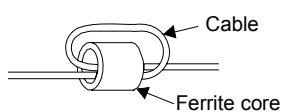

Cable Name	Mounting Position of the Core
I/O signals cable	Near the host controller and servodrive.
Motor cable	Near the servodrive and servomotor.
Encoder cable	Near the servodrive and servomotor.

(b) Recommended Ferrite-core

Cable Name		Ferrite Core Model	Manufacturer
I/O signals cable		ESD-SR-25	TOKIN
Encoder cable			
Motor cable	400W or less	PC40T96 × 20 × 70	TDK
	750W or less		

(c) Fixing the Cable

Fix and ground the cable shield using a piece of conductive metal.

- Example of Cable Clamp

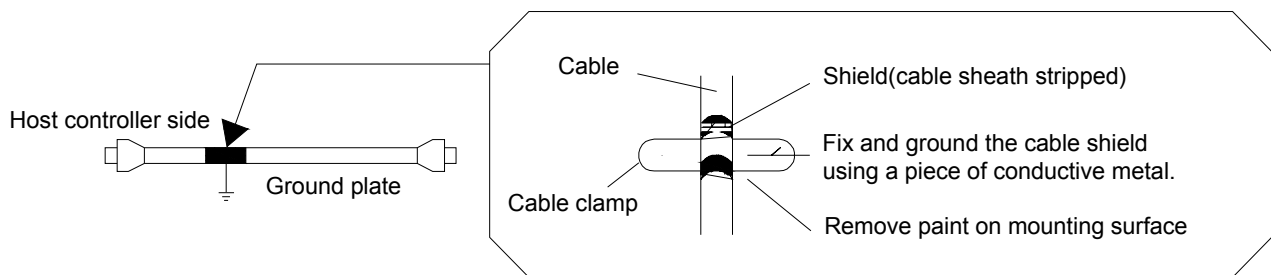

(d) Shield Box

A shield box, which is a closed metallic enclosure, should be used for shielding magnetic interference. The structure of the box should allow the main body, door, and cooling unit to be attached to the ground. The box opening should be as small as possible.



### 3.8 Using More than One Servo Drive

The following diagram is an example of the wiring when more than one Servodrive is used.

Connect the alarm output (ALM) terminals for the three Servodrives in series to enable alarm detection relay 1RY to operate.

When the alarm occurs, the ALM output signal transistor is turned OFF.

Multiple servos can share a single molded-case circuit breaker (QF) or noise filter. Always select a QF or noise filter that has enough capacity for the total power capacity (load conditions) of those servos.

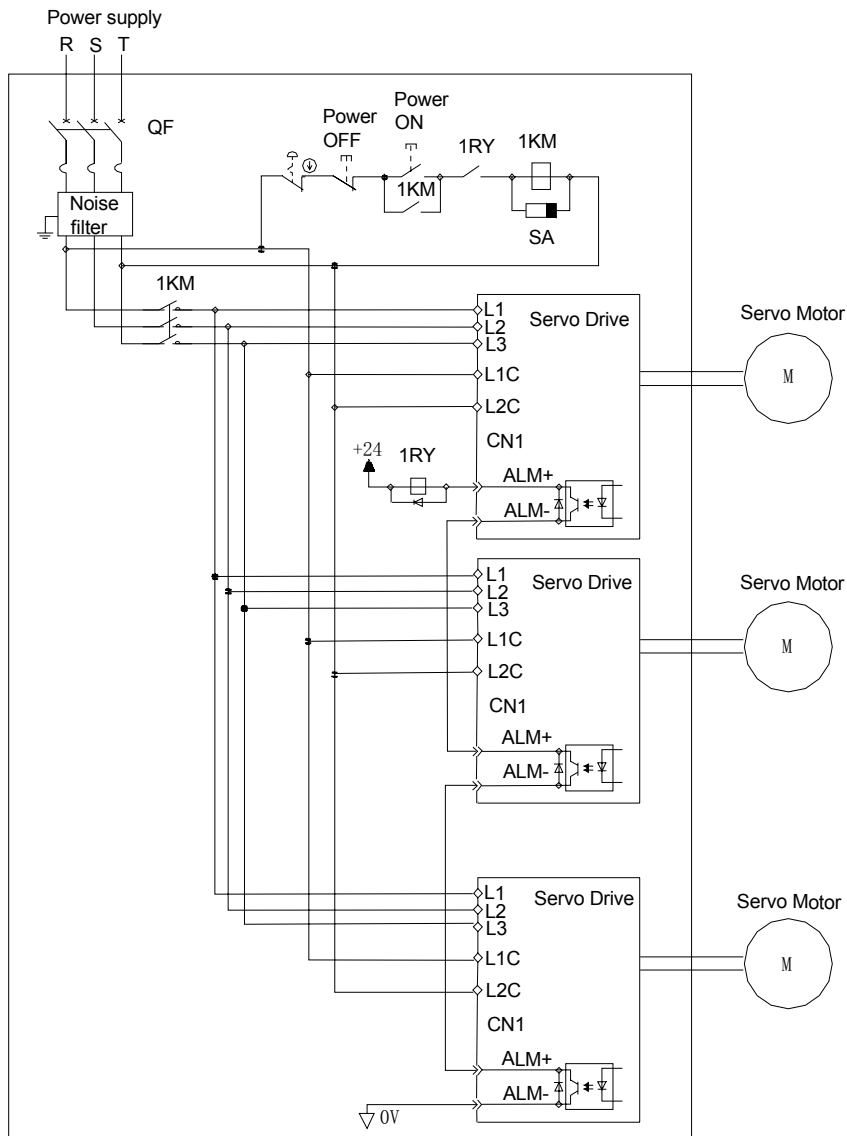

### 4.1 Trial Operation

Make sure that all wiring has been completed prior to trial operation.

Perform the following three types of trial operation in order. Instructions are given for speed control mode (standard setting) and position control mode. Unless otherwise specified, the standard parameters for speed control mode (factory settings) are used.

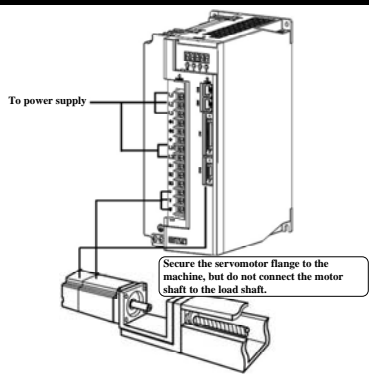
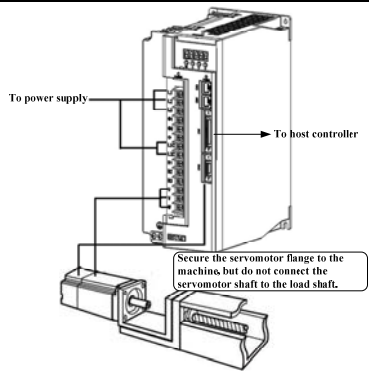
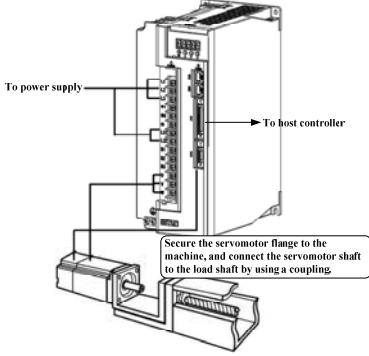
(1) Trial Operation for Servomotor Without Load (Refer to 4.1.1)	
	<p>■ Purpose</p> <p>The servomotor is operated without connecting the shaft to the machine in order to confirm the following wiring is correct.</p> <ul style="list-style-type: none"> <li>• Power supply circuit wiring</li> <li>• Servomotor wiring</li> <li>• Encoder wiring</li> <li>• Rotation direction and speed of servomotor.</li> </ul> <p style="text-align: right;">(Please refer to step 1-4)</p>
(2) Trial operation for servomotor with host reference (Refer to 4.1.2)	
	<p>■ Purpose</p> <p>The servomotor is operated without connecting the shaft to the machine in order to confirm the following wiring is correct.</p> <ul style="list-style-type: none"> <li>• I/O signal wiring with host controller</li> <li>• Rotation direction, speed and number of rotations of servomotor.</li> <li>• Check the operation of the brake, overtravel and other protective functions.</li> </ul> <p style="text-align: right;">(Please refer to step 5-8)</p>
(3) Trial operation for servomotor and machine combined. (Refer to 4.1.3)	
	<p>■ Purpose</p> <p>Perform the trial operation with the servomotor connected to the machine. The servodrive is adjusted to match the machine characteristics.</p> <ul style="list-style-type: none"> <li>• Servomotor speed and machine travel distance.</li> <li>• Set the necessary parameters.</li> </ul> <p style="text-align: right;">(Please refer to step 9-11)</p>

Step	Item	Description	Reference
1	Installation	Install the servomotor and servodrive according to the installation conditions. (Do not connect the servomotor to the machine because the servomotor will be operated first under the no-load condition for checking.)	-
↓			
2	Wiring	Connect the power supply circuit (L1, L2 and L3), servomotor wiring (U, V, W), I/O signal wiring (CN1), and encoder wiring (CN2). But during (1) Trial Operation for Servomotor Without Load, disconnect the CN1 connector.	-
↓			
3	Turn the power ON	Turn the power ON. Using the panel operator to make sure that the servodrive is running normally.	-
↓			
4	Execute JOG operation	Execute JOG operation with the servomotor alone under the no-load condition.	JOG Operation
↓			
5	Connect input signals	Connect the input signals (CN1) necessary for trial operation to the servodrive.	-
↓			
6	Check input signals	Use the internal monitor function to check the input signals. Turn the power ON, and check the emergency stop, brake, overtravel, and other protective functions for correct operation.	-
↓			
7	Input the Servo-ON signal	Input the Servo-ON signal, and turn ON the servomotor.	Host Reference
↓			
8	Input reference	Input the reference necessary for control mode, and check the servomotor for correct operation.	Host Reference
↓			
9	Protective operation	Turn the power OFF, and connect the servomotor to the machine.	-
↓			
10	Set necessary parameters.	Using the same procedure as you did to input a reference in step 8, operate the servomotor via the host controller and set the parameter to make sure the machine's travel direction, travel distance, and travel speed all correspond to the reference.	Host Reference
↓			
11	Operation	The servomotor can now be operated. Adjust the servo gain if necessary.	Host Reference



## 4.1.1 Trial Operation for Servomotor Without Load

### ⚠ CAUTION

- Release the coupling between the servomotor and the machine, and secure only the servomotor without a load.
- To prevent accidents, initially perform the trial operation for servomotor under no-load conditions (with all couplings and belts disconnected).



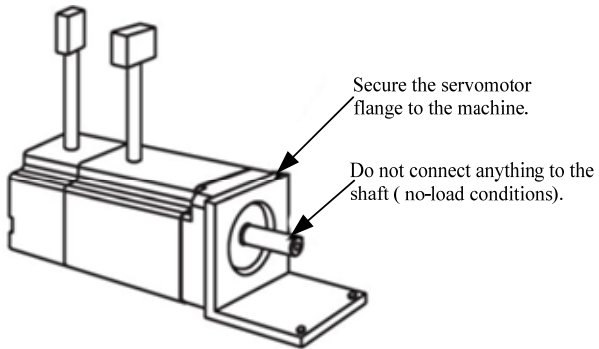
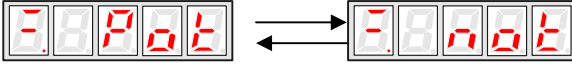

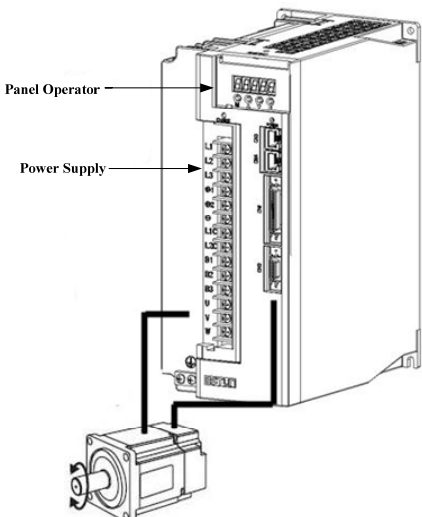

In this section, confirm the cable connections of the main circuit power supply, servomotor and encoder. Incorrect wiring is generally the reason why servomotors fail to operate properly during the trial operation.

Confirm the wiring, and then conduct the trial operation for servomotor without load according to the following steps.

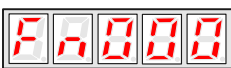
Step	Description	Check Method and Remarks
1	Secure the servomotor. 	Secure the servomotor flange to the machine in order to prevent the servomotor from moving during operation. Do not connect the servomotor shaft to the machine. The servomotor may tip over during rotation.
2	Check the power supply circuit, servomotor, and encoder wiring.	With the I/O signal connector (CN1) disconnected, check the power supply circuit and servomotor wiring. Refer to <b>3.1 Main Circuit Wiring</b> .
3	Turn ON the control power supply and main circuit power supply. Normal Display  Alternate Display Example of Alarm Display 	If the power is correctly supplied, the panel operator display on the front panel of the servodrive will appear as shown on the left. The display on the left indicates that forward run prohibited (P-OT) and reverse run prohibited (N-OT). If an alarm display appears, the power supply circuit, servomotor wiring, or encoder wiring is incorrect. If an alarm is displayed, turn OFF the power, find the problem, and correct it.
4	Release the brake before driving the servomotor when a servomotor with brake is used.	Please refer to <b>4.3.4 Setting for Holding Brakes</b> Please refer to <b>4.4 Operating Using Speed Control with Analog Reference</b>

Step	Description	Check Method and Remarks
5	 <p>Panel Operator</p> <p>Power Supply</p>	<p>Use the panel operator to operate the servomotor with utility function Fn002 (JOG Mode Operation). Check that the servomotor rotates in the forward direction by INC key, and reverse direction by DEC key.</p> <p>The operation is completed when the operation is performed as described below and the alarm display does not appear.</p> <p>Complete the Fn002 (JOG Mode Operation) and turn OFF the power.</p> <p>For operation method of the panel operator, refer to <b>Chapter 5 Panel Operator</b></p> <p>The servomotor speed can be changed using the Pn305 (JOG Speed). The factory setting for JOG speed is 500rpm.</p>

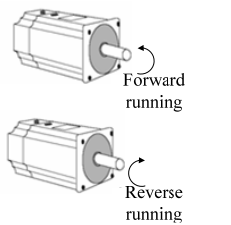
#### ■ JOG Mode Operation (Fn002)

Step	Display after operation	Panel operator	Description
1		MODE key	Press the MODE key to select the function mode.
2		INC or DEC key	Press the INC key or DEC key to select Fn002.
3		ENTER key	Press the ENTER key, and the servomotor will enter JOG operation mode.
4		MODE key	Press the MODE key. This will turn ON the power to the servomotor.
5	 <p>Forward running</p> <p>Reverse running</p>	INC or DEC key	The servomotor will run in forward direction when INC key pressed or in reverse direction when DEC key pressed. The servomotor will operate as long as the key is pressed.
6		MODE key	Press the MODE key. This will turn OFF the power to the servomotor.
7		ENTER key	Press the ENTER key to return to the Fn002 display of the utility function mode. Now, the servodrive is servo OFF.

#### Note:

The servomotor's rotation direction depends on the setting of parameter Pn001.0 (Direction Selection).

The example above describes operation with Pn001.0 in the factory setting.

Pn305	<b>JOG Speed</b>				
			Speed	Position	Torque
	<b>Setting Range</b>	<b>Setting Unit</b>	<b>Factory Setting</b>	<b>Setting Validation</b>	
	0~6000	rpm	500	Immediately	
Set the utility function Fn002 (JOG Mode Operation) to the reference value of servomotor speed.					

The servomotor can be operated using only the panel operator without reference from the host controller.

Pay attention that the Forward Run Prohibited (P-OT) and Reverse Run Prohibited (N-OT) signals are invalid during JOG mode operation.

### 4.1.2 Trial Operation for Servomotor without Load from Host Reference

Check that the servomotor move reference or I/O signals are correctly set from the host controller to the servodrive.

Also check the wiring and polarity between the host controller and servodrive, and the servodrive operation setting are correct. This is final check before connecting the servomotor to the machine.

#### (1) Servo ON Command from the Host

The following circuits are required: External input signal circuit or equivalent.

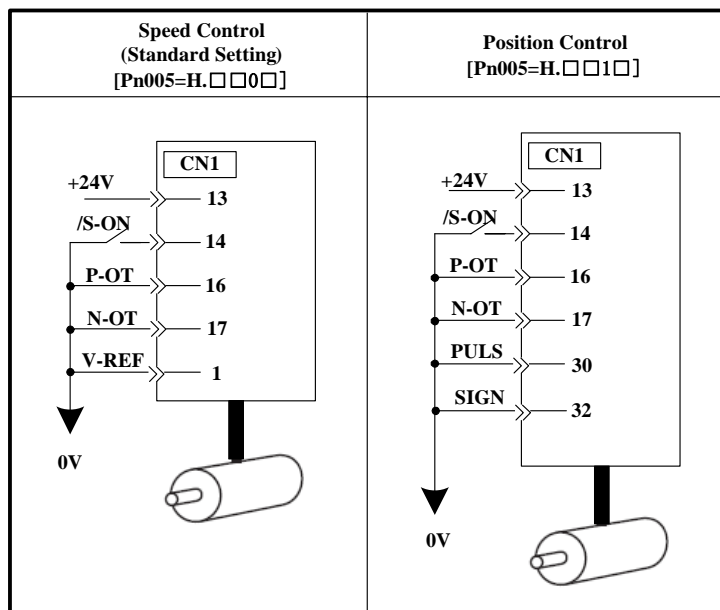

**(2) Operating Procedure in Speed Control Mode (Pn005=H. □□0□)**

The following circuit is required: External input signal circuit or equivalent.

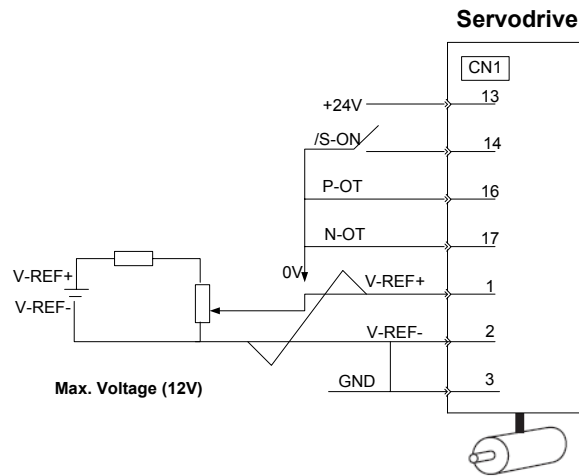

Step	Description	Check Method and Remarks
1	Check the power and input signal circuits again, and check that the speed reference input (voltage between the V-REF+ and V-REF-) is 0V.	Refer to the above figure for input signal circuit.
2	Turn ON the servo ON (/S-ON) input signal.	If the servomotor rotates at extremely slow speed, refer to <b>4.4.3 Adjusting Reference Offset</b> , and use the reference voltage offset to keep the servomotor from moving.
3	Generally increase the speed reference input voltage between V-REF+ and V-REF- from 0 V.	The factory setting is 6V/rated rotation speed.
4	Check the speed reference input to the servodrive (Un001[rpm])	Refer to <b>5.1.6 Operation in Monitor Mode</b> .
5	Check the Un000 (motor speed [rpm])	Refer to <b>5.1.6 Operation in Monitor Mode</b> .
6	Check that the Un001 and Un000 values in steps 4 and 5 are equal.	Change the speed reference input voltage and check that Un001 and Un000 are equal for multiple speed references.
7	Check the speed reference input gain and servomotor rotation direction.	Refer to the following equation to change the speed reference input gain (Pn300). $Un001 = (V-REF \text{ Voltage})[V] \times Pn300$ To change the servomotor rotation direction without changing polarity for speed reference input voltage, refer to <b>4.3.2 Switching the Servomotor Rotation Direction</b> . Perform the operation from step 2 again after the servomotor rotation direction is changed.
8	When the speed reference input is set to 0 V and servo OFF status enters, trial operation for servomotor without load is completed.	

■ When Position Control is configured at the Host

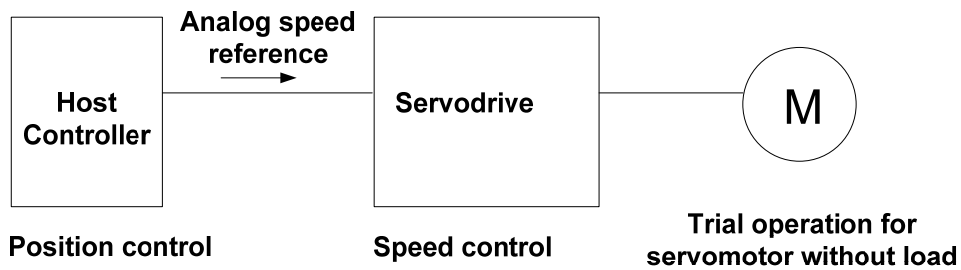

When the servodrive conducts speed control and position control is conducted at the host controller, perform the operation below, following the operation in **Operation Procedure in Speed Control Mode (Pn005=H. □□0□)**.

Step	Description	Check Method and Remarks
9	Check the input signal circuit again, and check that the speed reference input (between the V-REF+ and V-REF-) is 0 V.	Refer to the above figure for input signal circuit.
10	Turn the servo ON input signal (/S-ON) ON.	If the servomotor rotates at extremely slow speed, refer to <b>4.4.3 Adjusting Reference Offset</b> , and use the reference voltage offset to keep the servomotor from moving.
11	Send the command for the number of servomotor rotation easy to check ( for example, one servomotor revolution) from the host controller in advance, and check the sent number of rotation and actual number of rotation by visual inspection and the Un004(rotation angle)[pulse]	Refer to <b>5.1.6 Operation in Monitor Mode</b> for how it is displayed. Un004(rotation angle)[pulse]: The number of pulses from the zero point.
12	If the sent number of rotation and actual number of rotation in step 11 are not equal, correctly set the Pn200 (PG divided ratio) outputting the encoder pulse from the servodrive.	Refer to <b>4.4.8 Encoder Signal Output</b> for how to set PG divided ratio (Pn200[P/Rev]):The number of encoder pulses per revolution.
13	When the speed reference input is set to 0 V and servo OFF status enters, the trial operation for position control with the host controller is completed.	—



### (3) Operating Procedure in Position Control Mode (Pn005=H. □□1□)

The following circuit is required: External input signal circuit or equivalent.

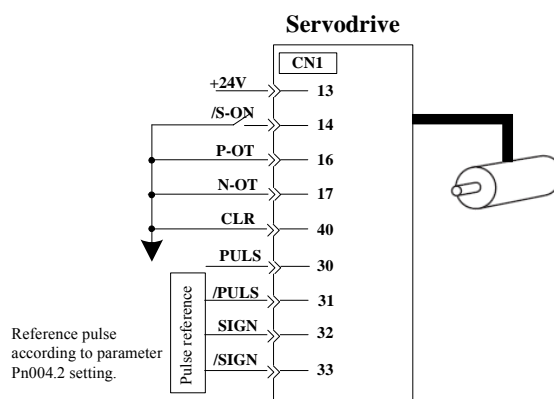

Step	Description	Check Method and Remarks
1	Match the reference pulse form with the pulse output form from the host controller.	Set the reference pulse form with Pn004.2.
2	Set the reference unit and electronic gear ratio so that it coincides with the host controller setting.	Set the electronic gear ratio with Pn201(or Pn203)/Pn202.
3	Turn the power and the servo ON input signal ON.	
4	Send the slow speed pulse reference for the number of servomotor rotation easy to check (for example, one servomotor revolution) from the host controller in advance.	Set the servomotor speed of several 100rpm for the reference pulse speed because such speed is safe.
5	Check the number of reference pulses input to the servodrive by the changed amount before and after the Un013 and Un014(input reference pulse counter)[pulse] were executed.	Refer to <b>5.1.6 Operation in Monitor Mode</b> for how it is displayed.
6	Check whether the actual number of servomotor rotation Un009、Un010 coincides with the number of input reference pulse.	Refer to <b>5.1.6 Operation in Monitor Mode</b> for how it is displayed.
7	Check that the servomotor rotation direction is the same as the reference.	Check the input pulse polarity and input reference pulse form.
8	Input the pulse reference with the large number of servomotor rotation from the host controller to obtain the constant speed.	Set the servomotor speed of serval 100rpm for the reference pulse speed because such speed is safe.
9	Check the reference pulse speed input to the servodrive using the Un008(input reference pulse speed)[rpm].	Refer to <b>5.1.6 Operation in Monitor Mode</b> for how it is displayed.
10	Check the servomotor speed using the Un000 (servomotor speed) [rpm].	Refer to <b>5.1.6 Operation in Monitor Mode</b> for how it is displayed.
11	Check the servomotor rotation direction.	To change the servomotor rotation direction without changing the input reference pulse form, refer to <b>4.3.2 Switching the Servomotor Rotation Direction</b> . Perform the operation from step 8 again after the servomotor rotation direction is changed.
12	When the pulse reference input is stopped and servo OFF status enters, the trial operation for servomotor without load in position control mode is completed.	—

### 4.1.3 Trial Operation with the Servomotor Connected to the Machine



- Follow the procedure below for trial operation precisely as given.
- Malfunctions that occur after the servomotor is connected to the machine not only damage the machine, but may also cause an accident resulting death or injury.

Follow the procedure below to perform the trial operation.

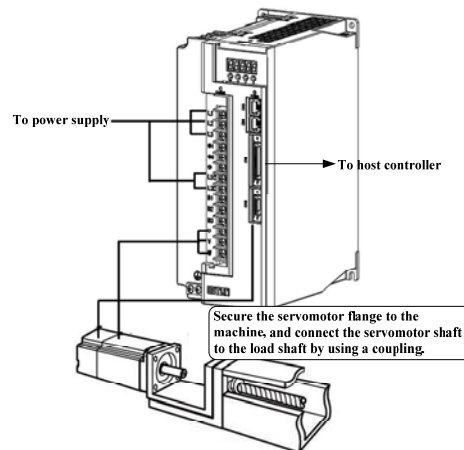

Step	Description	Check Method and Remarks
1	Turn the power ON and make the settings for mechanical configuration related to protective functions such as overtravel and brake.	Refer to <b>4.3 Setting Common Basic Functions</b> . When a servomotor with brake is used, take advance measures to prevent vibration due to gravity acting on the machine or external forces before checking the brake operation. Check that both servomotor and brake operations are correct. For details, refer to <b>4.3.4 Setting for Holding Brakes</b> .
2	Set the necessary parameters for control mode used.	Refer to <b>4.4 Operating Using Speed Control with Analog Reference</b> , <b>4.5 Operating Using Position Control</b> , and <b>4.6 Operating Using Torque Control</b> for control mode used.
3	Connect the servomotor to the machine with coupling, etc., while the power is turned OFF.	
4	Check that the servodrive is servo OFF status and then turn ON the power to the machine (host controller). Check again that the protective function in step 1 operates normally.	Refer to <b>4.3 Setting Common Basic Functions</b> . For the following steps, take advance measures for emergency stop so that the servomotor can stop safely when an error occurs during operation.
5	Perform trial operation with the servomotor connected to the machine, following each section in <b>4.1.2 Trial Operation for Servomotor without Load from Host Reference</b> .	Check that the trial operation is completed with as the trial operation for servomotor without load. Also, check the settings for machine such as reference unit.
6	Check the settings of parameters for control mode used set in step 2 again.	Check that the servomotor rotates matching the machine operating specifications.
7	Adjust the servo gain and improve the servomotor response characteristics, if necessary.	The servomotor will not be broken in completely during the trial operation. Therefore, let the system run for a sufficient amount of additional time to ensure that it is properly broken in.
8	Thus, the trial operation with the servomotor connected to the machine is completed.	

## 4.1.4 Trial Operation for Servomotor with Brakes

Holding brake operation of the servomotor with brake can be controlled with the brake interlock output (/BK) signal of the servodrive.

When checking the brake operation, take advance measures to prevent vibration due to gravity acting on the machine or external forces. Check the servomotor operation and holding brake operation with the servomotor separated from the machine. If both operations are correct, connect the servomotor with the machine and perform trial operation.

Refer to **4.3.4 Setting for Holding Brakes** for wiring on a servomotor with brakes and parameter settings.

## 4.1.5 Position Control by Host Controller

As described above, be sure to separate the servomotor and machine before performing trial operation of the servomotor without a load. Refer to the following table, and check the servomotor operation and specifications in advance.

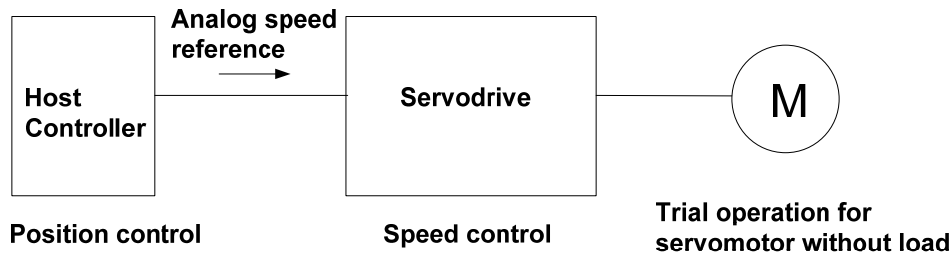

Reference from the Host Controller	Check Item	Check Method	Review Items
JOG Operation (Constan speed reference input from host controller)	Servomotor speed	Check servomotor speed as follows: <ul style="list-style-type: none"> <li>• Use the servomotor speed monitor(Un000) on the panel operator.</li> <li>• Run the servomotor at low speed.</li> </ul> For example, input a reference speed of 60rpm, and check to see if the servomotor makes one revolution per second.	Check the parameter setting at Pn300 to see if reference speed gain is correct.
Simple positioning	Number of servomotor rotation	Input a reference equivalent to one servomotor rotation and visually check to see if the shaft makes one revolution.	Check the parameter setting at Pn200 to see if the number of PG dividing pulses is correct.
Overtravel (P-OT and N-OT Used)	Whether the servomotor stops rotating when P-OT and N-OT signals are input.	Check to see if the servomotor stops when P-OT and N-OT signals are input during continuous servomotor operation.	Review P-OT and N-OT wiring if the servomotor does not stop.

## 4.2 Control Mode Selection

The control modes supported by the ProNet-E series servodrives are described below.

Parameter		Control Mode	Reference Section
Pn005	H. □□0□	<p><b>Speed Control (Analog voltage reference)</b></p> <p>Controls servomotor speed using analog voltage speed reference. Use in the following instances.</p> <ul style="list-style-type: none"> <li>• To control speed</li> <li>• For position control using the encoder feedback division output from the servodrive to form a position loop in the host controller.</li> </ul>	4.4
	H. □□1□	<p><b>Position Control(Pulse train reference)</b></p> <p>Controls the position of the servomotor using pulse train position reference.</p> <p>Controls the position with the number of input pulses, and controls the speed with the input pulse frequency.</p> <p>Use when positioning is required.</p>	4.5
	H. □□2□	<p><b>Torque Control (Analog voltage reference)</b></p> <p>Controls the servomotor's output torque with analog voltage torque reference. Use to output the required amount of torque for operations such as pressing.</p>	4.6
	H. □□3□	<p><b>Speed Control(contact reference) ↔ Speed Control (zero reference)</b></p> <p>Use the three input signals /P-CON, /P-CL and /N-CL to control the speed as set in advance in the servodrive.</p> <p>Three operating speeds can be set in the servodrive. (In this case, an analog reference is not necessary.)</p>	4.7
	H. □□4□ • • • H. □□E□	<p>These are swithing modes for using the four control methods described above in combination. Select the control method switching mode that best suits the application.</p>	4.9

## 4.3 Setting Common Basic Functions

### 4.3.1 Setting the Servo ON Signal

This sets the servo ON signal (/S-ON) that determines whether the servomotor power is ON or OFF.

#### (1) Servo ON signal(/S-ON)

Type	Name	Connector Pin Number	Setting	Meaning
Input	/S-ON	CN1-14 (Factory setting)	ON(low level)	Servomotor power ON. Servomotor can be operated.
			OFF(high level)	Servomotor power OFF. Servomotor cannot be operated.

#### ■Important

Always input the servo ON signal before inputting the input reference to start or stop the servomotor.

Do not input the input reference first and then use the /S-ON signal to start or stop. Doing so will degrade internal elements and result to malfunction.

A parameter can be used to re-allocate the input connector number for the /S-ON signal. Refer to

**3.2.2 I/O Signal Names and Functions.**

#### (2) Enabling/Disabling the Servo ON Signal

A parameter can be always used to set the servo ON condition. This eliminates the need to wire /S-ON, but care must be taken because the servodrive can operate as soon as the power is turned ON.

Parameter	Meaning
Pn000	b. □□□0 External S-ON signal enabled (Factory setting)
	b. □□□1 External S-ON signal disabled, the servomotor excitation signal is opened automatically after outputting the S-RDY signal.

• After changing these parameters, turn OFF the main circuit and control power supplies and then turn them ON again to enable the new settings.

### 4.3.2 Switching the Servomotor Rotation Direction

The rotation direction of the servomotor can be switched without changing the reference pulse to the servodrive or the reference voltage polarity.

This causes the travel direction(+,-) of the shaft reverse. The output signal polarity such as encoder pulse output and analog monitor signal from the servodrive does not change.

The standard setting for “forward rotation” is counterclockwise as viewed from the servomotor load end.

Parameter	Name	Reference	
		Forward reference	Reverse reference
Pn001	b.□□□0 Standard setting (CCW=forward) (factory setting)		
	b.□□□1 Reverse rotation mode (CW=forward)		

The direction of P-OT and N-OT change. For Pn001=b.□□□0(standard setting), counterclockwise is P-OT. For Pn001=b.□□□1(reverse rotation mode), clockwise is P-OT.

### 4.3.3 Setting the Overtravel Limit Function

The overtravel limit function forces movable machine parts to stop if they exceed the allowable range of motion and turn ON a limit switch.

#### (1) Connecting the overtravel signal

To use the overtravel function, connect the following overtravel limit switch to the corresponding pin number of servodrive CN1 connector correctly.

Type	Signal Name	Pin No.	Setting	Meaning
Input	P-OT	CN1-16 (factory setting)	ON(low level)	Forward rotation allowed. (Normal operation status.)
			OFF(high level)	Forward rotation prohibited. (Forward overtravel)
Input	N-OT	CN1-17 (factory setting)	ON(low level)	Reverse rotation (Normal operation status.)
			OFF(high level)	Reverse rotation prohibited. (Reverse overtravel)

Connect limit switches as shown below to prevent damage to the devices during linear motion.

Rotation in the opposite direction is possible during overtravel.

For example, reverse rotation is possible during forward overtravel.

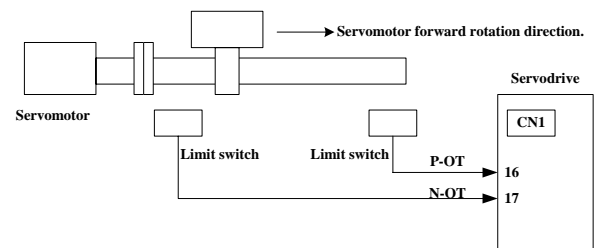

#### ■ Important

When using overtravel to stop the servomotor during position control, the position error pulses are present. A clear signal(CLR)input is required to clear the error pulses.

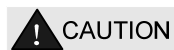

When using the servomotor on a vertical axis, the workpiece may fall in the overtravel condition.

To prevent this, always set the zero clamp after stopping with Pn004.0=5.

## (2) Enabling/Disabling the Overtravel Signal

A parameter can be set to disable the overtravel signal. If the parameter is set, there is no need to wire the overtravel input signal.

Parameter		Meaning
Pn000	b. □□0□	Inputs the forward rotation prohibited(P-OT) signal from CN1-16(factory setting).
	b. □□1□	Disables the forward rotation prohibited (P-OT) signal. (Allows constant forward rotation.)
	b. □0□□	Inputs the reverse rotation prohibited(N-OT) signal from CN1-17.(factory setting)
	b. □1□□	Disables the reverse rotation prohibited(N-OT) signal. (Allows constant reverse rotation.)
<ul style="list-style-type: none"> <li>• Applicable control modes: Speed control, position control, and torque control.</li> <li>• After changing these parameters, turn OFF the main circuit and control power supplies and then turn them ON again to enable the new settings.</li> <li>• A parameter can be used to re-allocate input connector number for the P-OT and N-OT signals. Refer to <b>3.2.2 I/O Signal Names and Functions</b>.</li> </ul>		

## (3) Selecting the Servomotor Stop Method

This is used to set the stop method when an overtravel(P-OT,N-OT)signal is input while the servomotor is operating.

Parameter	Stop Mode	Mode After Stopping	Meaning	
Pn004	H. □□□0	Stop by dynamic brake	Coast	Rapidly stops the servomotor by dynamic braking(DB), then places it into coast(power OFF) mode.
	H. □□□1	Coast to a stop		Stops the servomotor in the same way as when the servo is OFF(coast to a stop ), then places it into coast(power OFF) mode.
	H. □□□2	S-OFF /Overtravel	Coast	Stops the servomotor by dynamic braking (DB) when servo OFF, stops the servomotor by plug braking when overtravel, and then places it into coast (power OFF) mode.
	H. □□□3			Makes the servomotor coast to a stop state when servo OFF, stops the servomotor by plug braking when overtravel, and then places it into coast (power OFF) mode.
	H. □□□4		Zero Clamp	Stops the servomotor by dynamic braking (DB) when servo OFF, stops the servomotor by plug braking when overtravel, and then places it into zero clamp mode.
	H. □□□5			Makes the servomotor coast to a stop state when servo OFF, stops the servomotor by plug braking when overtravel, then places it into zero clamp mode.



- After changing these parameters, turn OFF the main circuit and control power supplies and then turn them ON again to enable the new settings.
- Stop by dynamic brake: Stops by using the dynamic brake (with short-circuiting by a circuit of servodrive).
- Coast to a stop: Stops naturally, with no brake, by using the friction resistance of the servomotor in operation.
- Plug braking: Stops by using plug braking limit torque.
- Zero Clamp Mode: A mode forms a position loop by using the position reference zero.

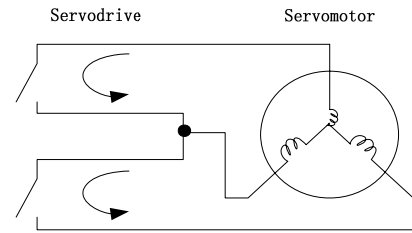

- Dynamic brake is an emergency stop function, and one of the general methods to cause a servomotor sudden stop.
- Dynamic brake suddenly stops a servomotor by shorting its electrical circuit.
- If the servomotor is frequently started and stopped by turning the power ON/OFF or using the servo ON signal(/S-ON), the DB circuit will also be repeatedly operated, degrading the servodrive's internal elements.
- Use the speed input reference and position reference to control the starting and the stopping of the servomotor.

#### (4)Setting the Stop Torque for Overtravel

Pn405	Plug braking torque limit`				
			Speed	Position	Torque
	Setting Range	Setting Unit	Factory Setting	Setting Validation	
	0~300	1%	300	Immediately	

- This sets the stop torque for when the overtravel signal(P-OT,N-OT) is input.
- The setting unit is a percentage of the rated torque.(the rated torque is 100%)
- The value large enough to be the servomotor maximum torque, 300% is set as the factory setting for plug braking limit torque.However, the actual output plug braking limit torque is determined by servomotor ratings.

### 4.3.4 Setting for Holding Brakes

The holding brake is used when the servodrive controls a vertical axis.

A servomotor with brake prevents the movable part from shifting due to gravity when the servodrive power goes OFF.

(Refer to 4.1.4 Trial Operation for Servomotor with Brakes.)

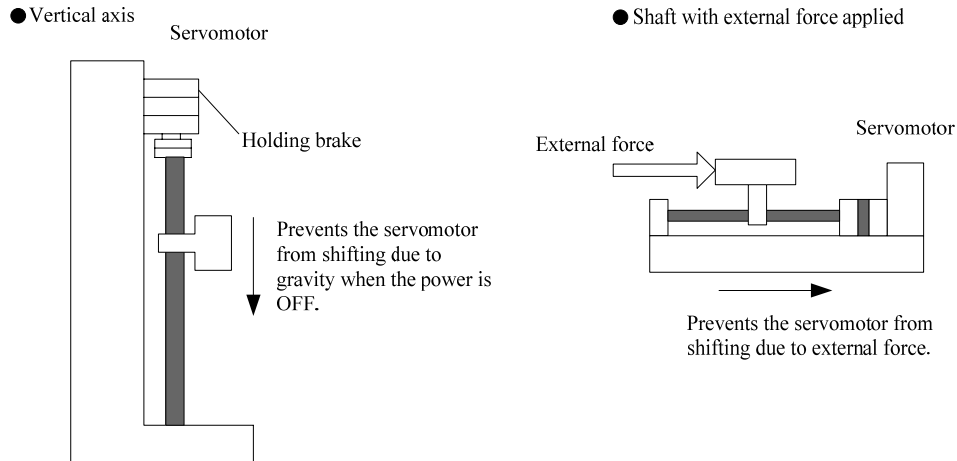

1. The brake built into the servomotor with brakes is a deenergization brake, which is used to hold and cannot be used for braking. Use the holding brake only to hold a stopped servomotor.
2. When operating using only a speed loop, turn OFF the servo and set the input reference to 0V when the brake is applied.
3. When forming a position loop, do not use a mechanical brake while the servomotor is stopped because the servomotor enters servolock status.

#### (1) Wiring Example

Use the servodrive sequence output signal /BK and the brake power supply to form a brake ON/OFF circuit.

The following diagram shows a standard wiring example.

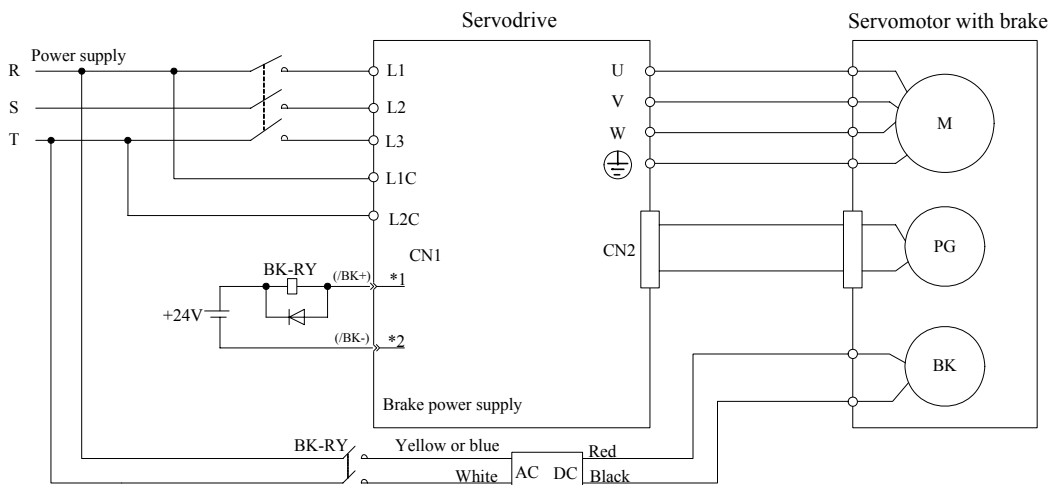

BK-RY: Brake control relay

1\*, 2\*: The output terminals allocated with Pn511.

**(2) Brake interlock output**

Type	Signal Name	Connector Pin Number	Setting	Meaning
Output	/BK	Must be allocated	ON(Low level)	Releases the brake.
			OFF(High level)	Applies the brake.

This output signal controls the brake and is used only for a servomotor with a brake. This output signal is not used with the factory setting. The output signal must be allocated by Pn511. It does not need to be connected for servomotor without a brake.

**(3) Allocating Brake Interlock Output (/Bk)**

Brake interlock output (/BK) is not used with the factory setting. The output signal must be allocated.

Parameter		Connector Pin Number		Meaning
		+ Terminal	- Terminal	
Pn511	H. □□□4	CN1-11	CN1-12	The /BK signal is output from output terminal CN1-11,12.
Pn511	H. □□4□	CN1-5	CN1-6	The /BK signal is output from output terminal CN1-5,6.
Pn511	H. □4□□	CN1-9	CN1-10	The /BK signal is output from output terminal CN1-9,10.

**■ Important**

When set to the factory setting, the brake signal is invalid.

For the allocation of servodrive output signals other than /BK signal, refer to **3.2.2 I/O Signal Names and Functions**.

Parameter Pn511 description as following:

0	/COIN(/V-CMP)output
1	/TGON rotation detecting output
2	/S-RDY servo drive get ready output
3	/CLT torque limit output
4	/BK brake interlock output
5	/PGC encoder C pulse output
6	OT overtravel signal output
7	/RD servo enabled motor excitation output
8	/HOME home completion output

Related parameter:

Parameter No.	Name	Unit	Setting Range	Default
Pn505	Servo ON waiting time	ms	-2000~2000	0
Pn506	Basic waiting flow	10ms	0~500	0
Pn507	Brake waiting speed	rpm	10~100	100
Pn508	Brake waiting time	10ms	10~100	50

**(4) Setting the Brake ON/OFF Timing after the Servomotor Stops**

With the factory setting, the /BK signal is output at the same time as the servo is turned OFF. The servo OFF timing can be changed with a parameter.

<b>Pn505</b>	<b>Servo ON waiting time</b>			
	<b>Setting Range</b>	<b>Setting Unit</b>	<b>Factory Setting</b>	<b>Setting Validation</b>
	-2000~2000	ms	0	Immediately
<b>Pn506</b>	<b>Basic waiting flow</b>			
	<b>Setting Range</b>	<b>Setting Unit</b>	<b>Factory Setting</b>	<b>Setting Validation</b>
	0~500	10ms	0	Immediately

•When using the servomotor to control a vertical axis, the machine movable part may shift slightly depending on the brake ON/ OFF timing due to gravity or an external force. By using this parameter to delay turning the servo ON/ OFF, this slight shift can be eliminated.

• For details on brake operation while the servomotor is operating, refer to (5) Setting the Brake ON/ OFF Timing When Servomotor Running in this section.

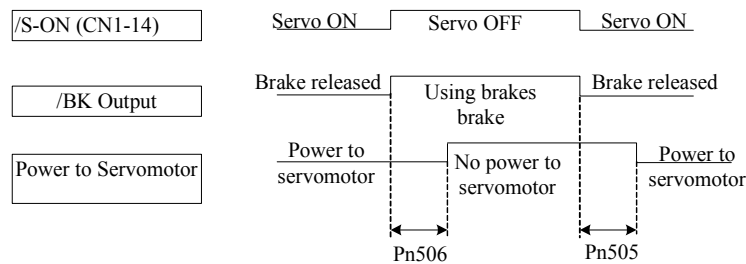

**■ Important**

- The servomotor will turn OFF immediately when an alarm occurs, regardless of the setting of this parameter.
- The machine movable part may shift due to gravity or external force during the time until the brake operates.

### (5) Setting the Brake ON/OFF Timing When Servomotor Running

The following parameters can be used to change the /BK signal output conditions when a stop reference is output during servomotor operation due to the servo OFF or an alarm occurring.

Pn507	<b>Brake Waiting Speed</b>			Speed	Position	Torque
	<b>Setting Range</b>	<b>Setting Unit</b>	<b>Factory Setting</b>	<b>Setting Validation</b>		
	10~100	1rpm	100	Immediately		
Pn508	<b>Brake Waiting Time</b>			Speed	Position	Torque
	<b>Setting Range</b>	<b>Setting Unit</b>	<b>Factory Setting</b>	<b>Setting Validation</b>		
	10~100	10ms	50	Immediately		

#### /BK Signal Output Conditions When Servomotor Running

The /BK signal goes to high level(brake ON) when either of the following conditions is satisfied:

- When the servomotor speed falls below the level set in Pn507 after servo OFF.
- When the time set in Pn508 is exceeded after servo OFF.

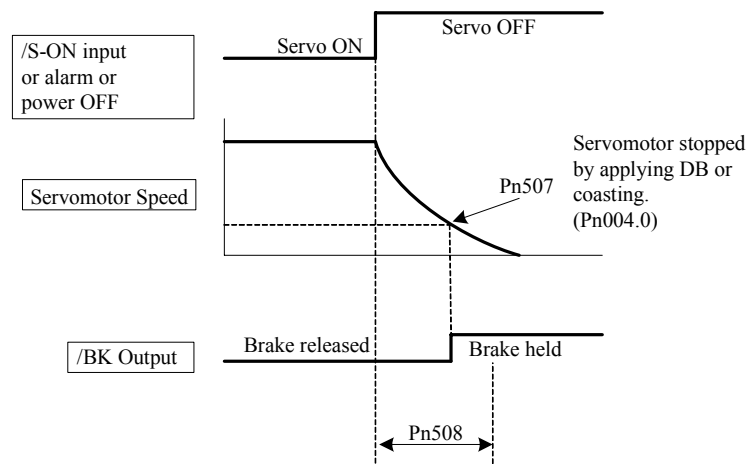

### 4.3.5 Instantaneous Power Loss Settings

Determines whether to continue operation or turn the servo OFF when the power supply voltage to the servodrive main circuit is instantaneously interrupted.

Parameter		Signal Name and Meaning
Pn000	b. 0□□□	Continue operation when the power supply voltage to servodrive main circuit is instantaneously interrupted.
	b. 1□□□	An alarm occurs when the power supply voltage to servodrive main circuit is instantaneously interrupted.

## 4.4 Operating Using Speed Control with Analog Reference

### 4.4.1 Setting Parameters

Parameter		Meaning
Pn005	H. □□□□	Control mode selection:Speed control(analog reference)(factory setting)

Pn300	Speed Reference Input Gain				
			Speed	Position	Torque
	<b>Setting Range</b>	<b>Setting Unit</b>	<b>Factory Setting</b>	<b>Setting Validation</b>	
	0~3000	rpm/v	150	Immediately	

Sets the analog voltage level for the speed reference(V-REF) necessary to operate the servomotor at the rated speed.

#### ■EXAMPLE

Pn300=150: 1V input is equivalent to the servomotor speed of 150rpm(factory setting).

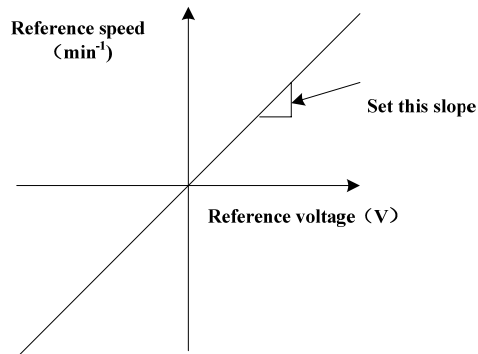

## 4.4.2 Setting Input Signals

### (1) Speed Reference Input

Input the speed reference to the servodrive using the analog voltage reference to control the servomotor speed in proportion to the input voltage.

Type	Signal Name	Connector Pin Number	Name
Input	V-Ref+	CN1-1	Speed Reference Input
	V-Ref-	CN1-2	Speed Reference Input

The above inputs are used for speed control(analog voltage reference).(Pn005.1=0, 4, 7, 9, A) Pn300 is used to set the speed reference input gain.Refer to **4.4.1 Setting Parameters**.

### (2) Proportional Control Reference (/P-CON)

Type	Signal	Connector Pin Number	Setting	Meaning
Input	/P-CON	CN1-15	ON(low level)	Operates the servodrive with proportional control
			OFF(high level)	Operates the servodrive with proportional integral control.

/P-CON signal selects either the PI(proportional integral) or P(proportional) Speed Control Mode.

Switching to P control reduces servomotor rotation and minute vibrations due to speed reference input drift.

Input reference: At 0V, the servomotor rotation due to drift will be reduced, but servomotor rigidity (holding force) drops when the servomotor is stopped.

Note: A parameter can be used to reallocate the input connector number for the /P-CON signal. Refer to **3.2.2 I/O Signal Names and Functions**.

### 4.4.3 Adjusting Reference Offset

When using the speed control, the servomotor may rotate slowly even if 0V is specified as the analog voltage reference. This happens if the host controller or external circuit has a slight offset (in the unit of mV) in the reference voltage.

Adjustments can be done manually or automatically by using the panel operator. Refer to **5.2 Operation in Utility Function Mode**.

The servodrive automatically adjusts the offset when the host controller or external circuit has the offset in the reference voltage.

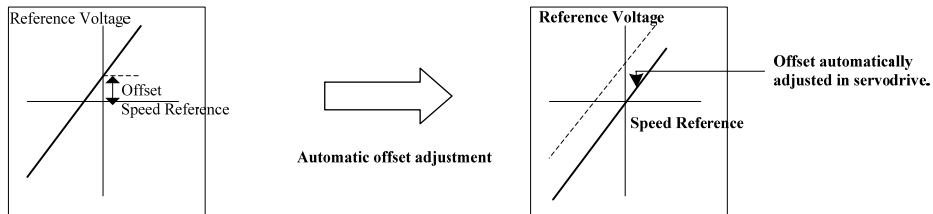

After completion of the automatic adjustment, the amount of offset is stored in the servodrive. The amount of offset can be checked in the speed reference offset manual adjustment mode (Fn004). Refer to **4.4.3 (2) Manual Adjustment of the Speed Reference Offset**.

#### (1) Automatic Adjustment of the Speed Reference Offset

The automatic adjustment of reference offset (Fn003) cannot be used when a position loop has been formed with a host controller and the error pulse is changed to zero at the servomotor stop due to servolock. Use the speed reference offset manual adjustment (Fn004) described in the next section for a position loop.

The zero-clamp speed control function can be used to force the servomotor to stop while the zero speed reference is given. Refer to **4.4.7 Using the Zero Clamp Function**.

---

**Note:** The speed reference offset must be automatically adjusted with the servo OFF.

---

Adjust the speed reference offset automatically in the following procedure.

1. Turn OFF the servodrive and input the 0V reference voltage from the host controller or external circuit.

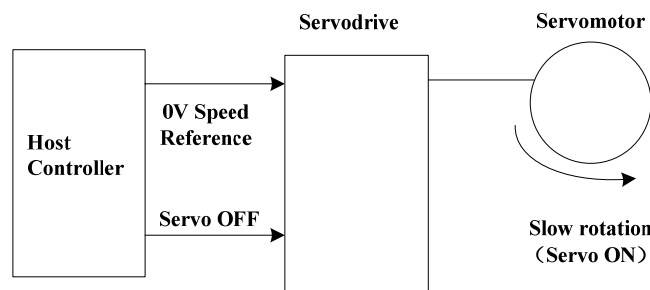

2. Press the MODE key to select the utility function mode.
3. Press the INC or DEC key to select parameter Fn003.





4. Press the ENTER key to enter into the speed reference offset automatic adjustment mode.

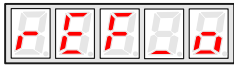

5. Press the MODE key for more than one second, the reference offset will be automatically adjusted.

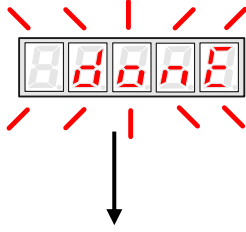

7. Press ENTER key to return to the Fn003 display of the utility function mode.



8. Thus, the speed reference offset automatic adjustment is completed.

## (2) Manual Adjustment of the Speed Reference Offset

Use the speed reference offset manual adjustment (Fn004) in the following situations:

- If a loop is formed with the host controller and the position error pulse is set to be zero when servolock is stopped.
- To deliberately set the offset to some value
- To check the offset data set in the speed reference offset automatic adjustment mode.

This function operates in the same way as the reference offset automatic adjustment mode (Fn003), except that the amount of offset is directly input during the adjustment.

The offset setting range and setting unit are as follows:

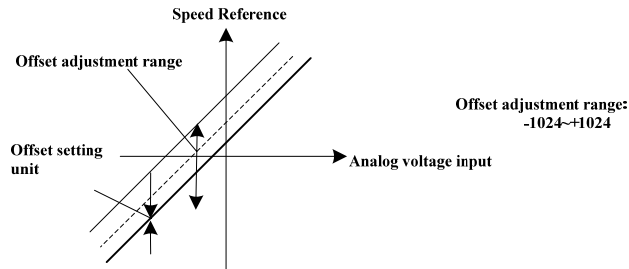

Adjust the speed reference offset manually in the following procedure.

1. Press the MODE key to select the utility function mode.
2. Press the INC or DEC key to select parameter Fn004.

3. Press the ENTER key to enter into the speed reference offset manual adjustment mode.

4. Turn ON the servo ON (/S-ON) signal. The display will be shown as below.

5. Press the ENTER key for one second to display the speed reference offset amount.

6. Press the INC or DEC key to adjust the amount of offset.
7. Press the ENTER key for one second to return to the display in step 4.
8. Press the ENTER key to return to the Fn004 display of the utility function mode.

9. Thus, the speed reference offset manual adjustment is completed.

## 4.4.4 Soft Start

The soft start function converts the stepwise speed reference inside the servodrive to a consistent rate of acceleration and deceleration.

Pn310 can be used to select the soft start form:

0: Slope; 1: S curve; 2: 1<sup>st</sup>-order filter; 3: 2<sup>nd</sup>-order filter

Pn306	Soft Start Acceleration Time			Speed
	<b>Setting Range</b>	<b>Setting Unit</b>	<b>Factory Setting</b>	<b>Setting Validation</b>
	0~10000	1ms	0	Immediately
Pn307	Soft Start Deceleration Time			Speed
	<b>Setting Range</b>	<b>Setting Unit</b>	<b>Factory Setting</b>	<b>Setting Validation</b>
	0~10000	1ms	0	Immediately

The soft start function enables smooth speed control when inputting a stepwise speed reference or when selecting internally set speeds. Set both Pn306 and Pn307 to "0" for normal speed control.

Set these parameters as follows:

- Pn306: The time interval from the time the servomotor starts until the servomotor maximum speed is reached.
- Pn307: The time interval from the time the servomotor is operating at the servomotor maximum speed until it stops.

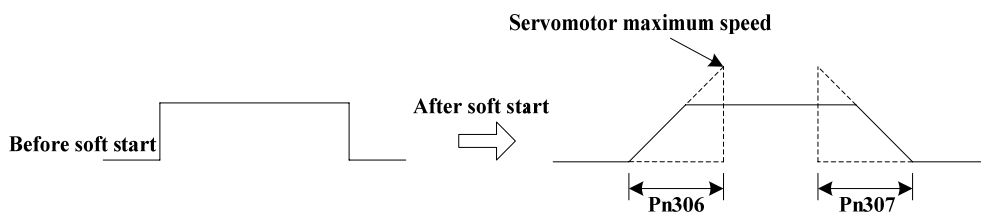

## 4.4.5 Speed Reference Filter Time Constant

Pn308	Speed Reference Filter Time Constant			Speed
	<b>Setting Range</b>	<b>Setting Unit</b>	<b>Factory Setting</b>	<b>Setting Validation</b>
	0~10000	1ms	0	Immediately

This smoothens the speed reference by applying a 1<sup>st</sup>-order delay filter to the analog speed reference (V-REF) input. A value that is too large, however, will slow down response.

## 4.4.6 S-curve Risetime

Pn309	S-curve Risetime			Speed
	<b>Setting Range</b>	<b>Setting Unit</b>	<b>Factory Setting</b>	<b>Setting Validation</b>
	0~10000	1ms	0	Immediately

  

## 4.4.7 Using the Zero Clamp Function

### (1) Zero Clamp Function

The zero clamp function is used for systems where the host controller does not form a position loop for the speed reference input. When the zero clamp signal ( $/P-CON$ ) is ON, a position loop is formed inside the servodrive as soon as the input voltage of the speed reference ( $V-REF$ ) drops below the servomotor zero clamp speed. The servomotor ignores the speed reference and then quickly stops and locks the servomotor.

The servomotor is clamped within  $\pm 1$  pulse when the zero clamp function is turned ON, and will still return to the zero clamp position even if it is forcibly rotated by external force.

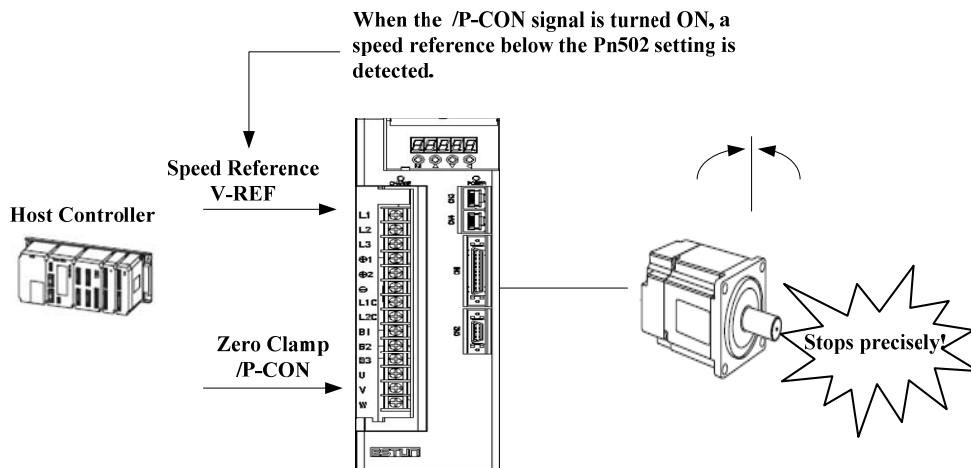

## (2) Parameter Setting

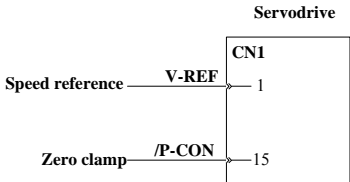
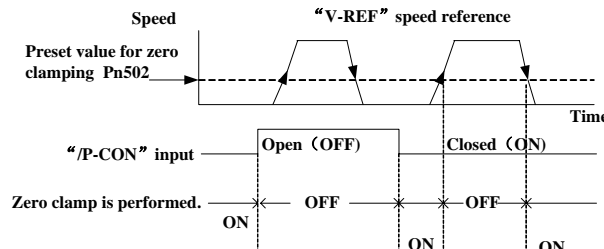
Parameter		Meaning
Pn005	H.□□A□	Control mode: Speed control(analog voltage reference) ↔ Zero Clamp
<p>Zero Clamp Conditions:</p> <p>Zero clamp is performed with Pn005=H. □□A□ when the following two conditions are both satisfied:</p> <ul style="list-style-type: none"> <li>• /P-CON is ON (low level)</li> <li>• Speed reference (V-REF) drops below the setting of Pn502.</li> </ul>		
 		

Pn502	Zero clamp speed			
	Speed			
	<b>Setting Range</b>	<b>Setting Unit</b>	<b>Factory Setting</b>	<b>Setting Validation</b>
	0~3000	rpm	10	Immediately
Sets the servomotor speed at which the zero clamp is performed if zero clamp speed control(Pn005=H.□□A□) is selected. Even if this value is set higher than the maximum speed of the servomotor, the maximum speed will be used.				

## (3) Input Signal Setting

Type	Signal Name	Connector Pin Number	Setting	Meaning
Input	/P-CON	CN1-15	ON(low level)	Zero clamp function ON(enabled)
			OFF(high level)	Zero clamp function OFF(disabled)
/P-CON is the input signal to switch to the zero clamp function.				

## 4.4.8 Encoder Signal Output

Encoder feedback pulses processed inside the servodrive can be output externally.

Type	Signal Name	Connector Pin Number	Name
Output	PAO	CN1-20	Encoder output phase A
	/PAO	CN1-21	Encoder output phase /A
Output	PBO	CN1-22	Encoder output phase B
	/PBO	CN1-23	Encoder output phase /B
Output	PCO	CN1-24	Encoder output phase C(zero-point pulse)
	/PCO	CN1-25	Encoder output phase /C(zero-point pulse)

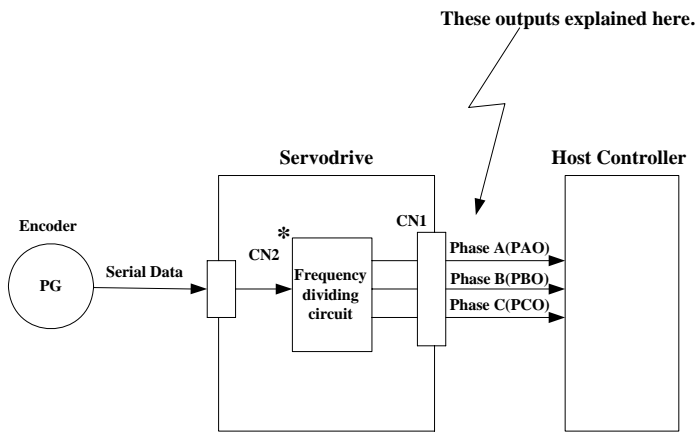

\* The dividing output phase form is the same as the standard setting(Pn001.0=0) even in the reverse rotation mode(Pn001.0=1).

■ Output phase form

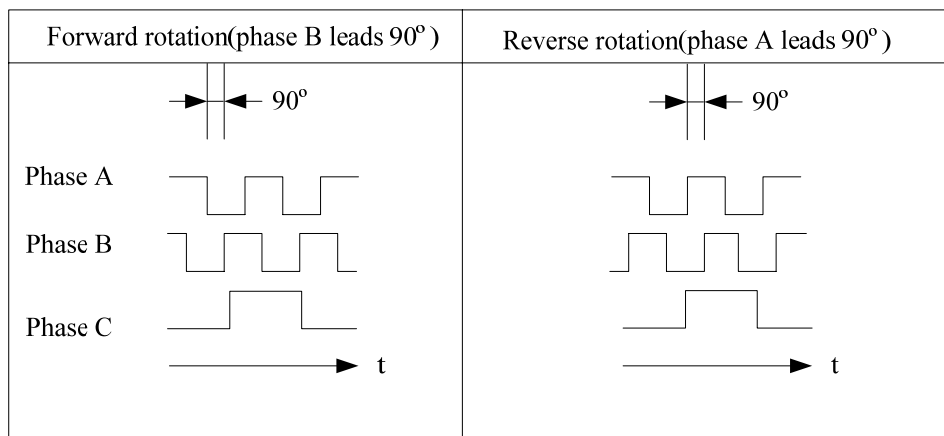

Servomotor needs two circles rotation before using the servodrive's phase-C pulse output for zero point reference.

**Dividing:** The dividing means that the divider converts data into the pulse density(Pn200) based on the pulse data of the encoder installed on the servomotor, and outputs it. The setting unit is the number of pulses/revolution.

■ **Pulse Dividing Ratio Setting**

Pn200	PG Dividing Ratio			Speed	Position	Torque
	<b>Setting Range</b>	<b>Setting Unit</b>	<b>Factory Setting</b>	<b>Setting Validation</b>		
	16~16384(Pn840.0=3/4/5) 1~2500 (Pn840.0=6)	1Puls	16384 (Pn840.0=3/4/5) 2500 (Pn840.0=6)	After restart		

Set the number of pulses for PG output signals(PAO,/PAO,PBO,/PBO) externally from the servodrive.

Feedback pulses from the encoder per revolution are divided inside the servodrive by the number set in Pn200 before being output. (Set according to the system specifications of the machine or host controller.)

The setting range varies with the number of encoder pulses for the servomotor used.

■ **Output Example**

Pn200=16(when 16 pulses are output per revolution)

**Preset value: 16**

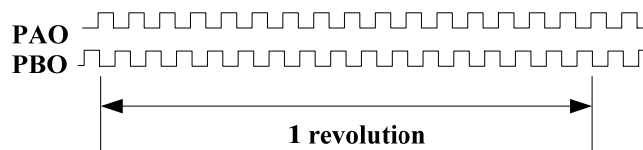

### 4.4.9 Speed coincidence output

The speed coincidence (/V-CMP) output signal is output when the actual servomotor speed during speed control is the same as the speed reference input. The host controller uses the signal as an interlock.

Type	Signal Name	Connector Pin Number	Setting	Meaning
Output	/V-CMP(/COIN)	CN1-11, 12 (factory setting)	ON(low level)	Speed coincides.
			OFF(high level)	Speed does not coincide.

Pn501	Coincidence Difference			Speed
	<b>Setting Range</b>	<b>Setting Unit</b>	<b>Factory Setting</b>	<b>Setting Validation</b>
	0~100	rpm	10	Immediately

The /V-CMP signal is output when the difference between the speed reference and actual servomotor speed is less than Pn501.

■ **Example**

The /V-CMP signal turns ON at 1900 to 2100rpm if the Pn501 parameter is set to 100 and the reference speed is 2000rpm.

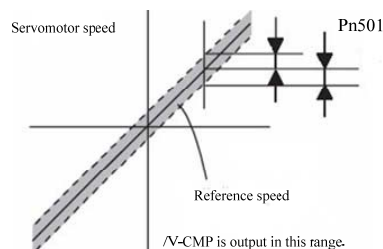

■ **Note**

This pin outputs the /COIN signal in position control mode, and the /V-CMP signal in speed control mode.

## 4.5 Operating Using Position Control

Set the following parameters for position control using pulse trains.

Parameter		Meaning
Pn005	H. □□1□	Control mode selection: position control(pulse train reference)

A block diagram for position control is shown as below.

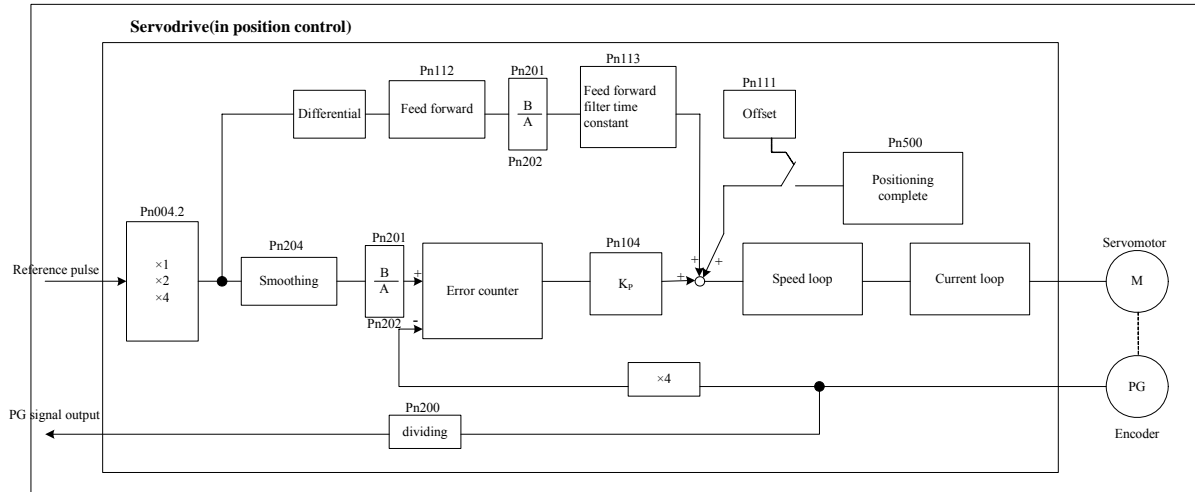

### 4.5.1 Basic Setting in Position Control

#### (1) Setting a reference pulse sign

Type	Signal Name	Connector Pin Number	Name
Input	PULS	CN1-30	Reference pulse input
	/PULS	CN1-31	Reference pulse input
	SIGN	CN1-32	Reference sign input
	/SIGN	CN1-33	Reference sign input

#### (2) Setting reference input filter for open collector signal

When Pn840.0=3/4/5

Pn006	0□□□	when pulse is difference input, servo receiving pulse frequency $\leq 4M$
	1□□□	when pulse is difference input, servo receiving pulse frequency $\leq 650K$
	2□□□	when pulse is difference input, servo receiving pulse frequency $\leq 150K$

When Pn840.0=6

Pn006	0□□□	when pulse is difference input, servo receiving pulse frequency $\leq 700K$
	1□□□	when pulse is difference input, servo receiving pulse frequency $\leq 200K$
	2□□□	when pulse is difference input, servo receiving pulse frequency $\leq 60K$



### (3) Setting a Reference Pulse Form

Set the input form for the servodrive using parameter Pn004.2 according to the host controller specifications.

Parameter	Reference Pulse Form	Input Pulse Multiplier	Forward Rotation Reference	Reverse Rotation Reverse	
Pn004	H. 0□□□	Sign+pulse train (positive logic) (factory setting)			
	H. 1□□□	CW+CCW (positive logic)			
	H. 2□□□	Two-phase pulse train with 90° phase differential (positive logic)	×1		
	H. 3□□□		×2		
	H. 4□□□		×4		

■ Note:

The input pulse multiplier can be set for the two-phase pulse train with 90° phase differential reference pulse form.

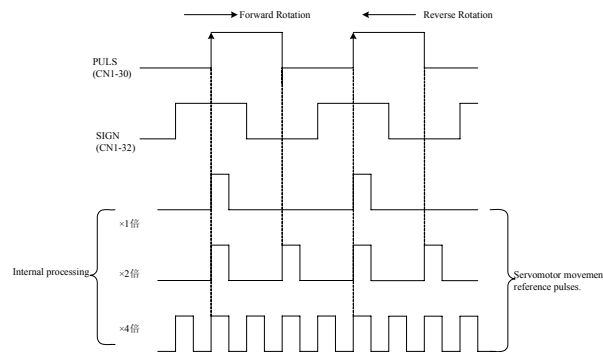

### (4) Inverses PULS and SIGN reference

Pn004	0□□□	Do not invert PULS reference and SIGN reference
	1□□□	Do not invert PULS reference; Inverts SIGN reference
	2□□□	Invert PULS reference; Do not invert SIGN reference
	3□□□	Invert PULS reference and SIGN reference.

**(5)Reference Pulse Input Signal Timing**

Reference pulse signal form	Electrical specifications	Remarks
Sign+pulse train input (SIGN+PULS signal) Maximum reference frequency: 500kpps (For open-collector output: 200kpps)	<p> <math>t1, t2=0.1\mu s</math>  <math>t3, t7=0.1\mu s</math>  <math>t4, t5, t6=3\mu s</math>  <math>t=1.0\mu s</math>  <math>(t/T) \times 100 = 50\%</math> </p>	SIGN H=forward reference L=reverse reference
CW pulse+CCW pulse Maximum reference frequency:500kpps (For open-collector output: 200kpps)	<p> <math>t1, t2=0.1\mu s</math>  <math>t3&gt;3\mu s</math>  <math>t=1.0\mu s</math>  <math>(t/T) \times 100 = 50\%</math> </p>	
Two-phase pulse train with 90° phase differential(phase A +B) Maximum reference frequency: ×1 input pulse multiplier: 500kpps ×2 input pulse multiplier: 400kpps ×4 input pulse multiplier: 200kpps	<p> <math>t1, t2=0.1\mu s</math>  <math>t=1.0\mu s</math>  <math>(t/T) \times 100 = 50\%</math> </p> <p>Phase B leads A by 90°. Phase B lags B by 90°.</p>	A parameter Pn004.2 can be used to switch of the input pulse multiplier mode.

**(6)Connection Example**

The pulse train output form from the host controller corresponds to the following:

- Line-driver Output
- +24V Open-collector output
- +12V/+5V Open-collector output

(a)Connection Example for Line-driver Output

Applicable line driver: SN75174 manufactured by TI or MC3487 or the equivalent.

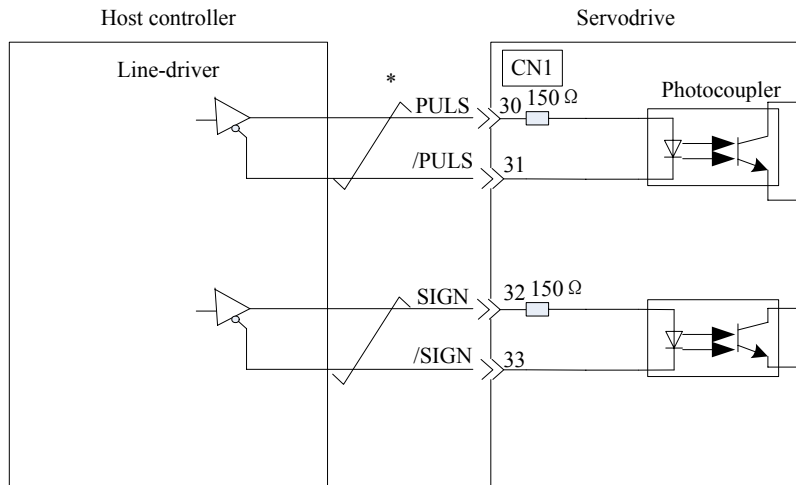

\* Represents twisted-pair wires.

(b) Connection Example for Open-collector Output

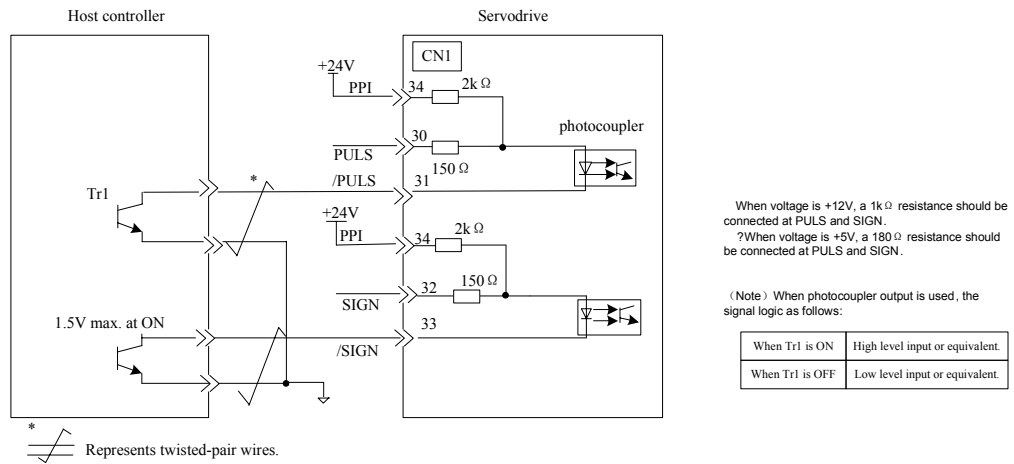

---

**Note:** When the host controller applied by open-collector signal output, input signal noise margin lowers. When a position error caused by the noise occurs, set the parameter Pn006.3.

---

## 4.5.2 Setting the Clear Signal

### (1) Setting the Clear Signal

Type	Sign Name	Connector Pin Numbe	Function
Input	/CLR	1CN-40	error counter clear

When the /CLR signal is set to low level, clear error counter:

- The error counter inside the servo drive is set to "0"
- Position loop operation is disabled.

### (2) Setting the Clear Signal Mode

In position control mode, pulses will be still presented in the servo drive when servo OFF, thus it should be cleared when servo drive is turned ON. Setting Pn004 to choose whether clearing the pulses automatically when servo OFF.

Pn004	<input type="checkbox"/> <input type="checkbox"/> <input type="checkbox"/> <input type="checkbox"/>	Clear the error pulse when S-OFF, do not when overtravel.
	<input type="checkbox"/> <input type="checkbox"/> <input type="checkbox"/> <input type="checkbox"/>	Do not clear the error pulse.
	<input type="checkbox"/> <input type="checkbox"/> <input type="checkbox"/> <input type="checkbox"/>	Clear the error pulse when S-OFF or overtravel (except for zero clamp)

## 4.5.3 Setting the Electronic Gear

### (1) Electronic Gear

The electronic gear enables the workpiece travel distance per input reference pulse from the host controller to be set to any value.

One reference pulse from the host controller, i.e., the minimum position data unit, is called a reference unit.

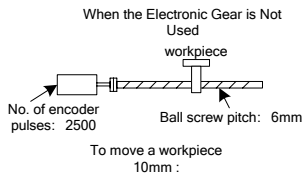

One revolution is 6mm. Therefore  $10 \div 6 = 1.6666$  revolutions.  
 $2500 \times 4$  pulses is one revolution.  
 Therefore,  $1.6666 \times 2500 \times 4 = 16666$  pulses. 16666 pulses are input as reference pulses.  
 The equation must be calculated at the host controller.

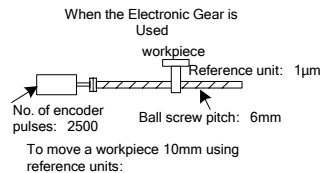

The reference unit is 1µm. Therefore, to move the workpiece 10mm ( $10000\mu\text{m}$ ),  $1\text{ pulse} = 1\mu\text{m}$ , so  $10000/1 = 10000$  pulses.  
 Input 10000 pulses per 10mm of workpiece movement.

## (2) Related Parameters

Pn201	Electronic Gear Ratio(Numerator)			Position
	<b>Setting Range</b>	<b>Setting Unit</b>	<b>Factory Setting</b>	<b>Setting Validation</b>
	1~65535	—	1	After restart
Pn202	Electronic Gear Ratio(Denominator)			Position
	<b>Setting Range</b>	<b>Setting Unit</b>	<b>Factory Setting</b>	<b>Setting Validation</b>
	1~65535	—	1	After restart
<p>If the deceleration ratio of the servomotor and the load shaft is given as n/m where m is the rotation of the servomotor and n is the rotation of the load shaft.</p> <p>Electronic gear ratio: <math>\frac{B}{A} = \frac{Pn201}{Pn202}</math></p> $= \frac{\text{No. of encoder pulses} \times 4}{\text{Travel distance per load shaft revolution (reference units)}} \times \frac{m}{n}$ <ul style="list-style-type: none"> <li>• If the ratio is outside the setting range, reduce the fraction (both numerator and denominator) until you obtain integers within the range.</li> <li>• Be careful not to change the electronic gear ratio (B/A).</li> </ul> <p>■ Important</p> <ul style="list-style-type: none"> <li>• Electronic gear ratio setting range: <math>0.01 \leq \text{electronic gear ratio (B/A)} \leq 100</math></li> <li>• If the electronic gear ratio is outside this range, the servodrive will not operate properly. In this case, modify the load configuration or reference unit.</li> </ul>				

## (3) Procedure for Setting the Electronic Gear Ratio

Use the following procedure to set the electronic gear ratio.

Step	Operation	Description
1	Check machine specifications.	Check the deceleration ratio, ball screw pitch and pulley diameter.
2	Check the number of encoder pulses.	Check the number of encoder pulses for the servomotor used.
3	Determine the reference unit used.	Determine the reference unit from the host controller, considering the machine specifications and positioning accuracy.
4	Calculate the travel distance per load shaft revolution.	Calculate the number of reference units necessary to turn the load shaft one revolution based on the previously determined reference units.
5	Calculate the electronic gear ratio.	Use the electronic gear ratio equation to calculate the ratio (B/A).
6	Set parameters.	Set parameters using the calculated values.

#### (4) Electronic Gear Ratio Setting Examples

The following examples show electronic gear ratio settings for different load configurations.

Step	Operation	Load Configuration					
		Ball Screw	Disc Table	Belt and Pulley			
1	Check machine specifications.	Ball screw pitch:6mm Deceleration ratio:1/1	Rotation angle per revolution :360° eceleration ratio:3/1	Pulley diameter:100 mm (pulley circumference:314 mm) ·Deceleration ratio:2/1			
2	Encoder	2500P/R	2500P/R	2500P/R			
3	Determine the rference unit used	1 reference unit: 0.001mm(1μm)	1 reference unit:0.1°	1 reference unit:0.2mm			
4	Calculate the travel distance per load shaft revolution	6mm/0.001mm=6000	360°/0.1°=3600	314mm/0.2mm=1570			
5	Calculate the electronic gear ratio	$\frac{B}{A} = \frac{2500 \times 4}{6000} \times \frac{1}{1}$	$\frac{B}{A} = \frac{2500 \times 4}{3600} \times \frac{3}{1}$	$\frac{B}{A} = \frac{2500 \times 4}{1570} \times \frac{2}{1}$			
6	Set parameters	Pn201	10000	Pn201	30000	Pn201	20000
		Pn202	6000	Pn202	3600	Pn202	1570
7	Final Result	Pn201	5	Pn201	25	Pn201	2000
		Pn202	3	Pn202	3	Pn202	157

- Reduce the fraction (both numerator and denominator) if the calculated result will not be within the setting range.

#### (5) Electronic Gear Ratio Equation

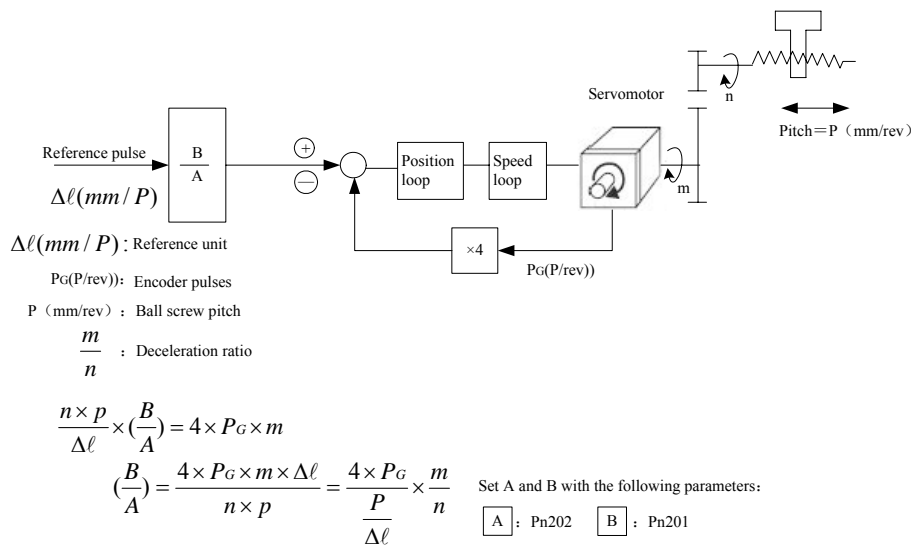

## 4.5.4 Smoothing

A filter can be applied in the servodrive to a constant-frequency reference pulse.

### (1) Selecting a Position Reference Filter

Parameter	Description
Pn205	0: 1 <sup>st</sup> -order filter
	1: 2 <sup>nd</sup> -order filter

\* After changing the parameter, turn OFF the power once and turn it ON again to enable the new setting.

### (2) Filter-related Parameters

Pn204	Position Reference Acceleration/Deceleration Time Constant				Position
	<b>Setting Range</b>	<b>Setting Unit</b>	<b>Factory Setting</b>	<b>Setting Validation</b>	
	0~32767	0.1ms	0	Immediately	

■ Important

When the position reference acceleration/deceleration time constant (Pn204) is changed, a value with no reference pulse input and a position error of 0 will be enabled. To ensure that the setting value is correctly reflected, stop the reference pulse from the host controller and input the clear signal (CLR), or turn OFF to clear the error.

This function provides smooth servomotor operating in the following cases.

- When the host controller that outputs a reference cannot perform acceleration/deceleration processing.
- When the reference pulse frequency is too low.
- When the reference electronic gear ratio is too high (i.e., 10× or more)

## 4.5.5 Low Frequency Vibration Suppression

### (1) Note:

For the low rigidity load, low frequency vibration will be occurred continually at the front end of the load during fast starting or fast stopping. The vibration may delay positioning time and affect the productive efficiency.

The function of low frequency vibration suppression is embedded in ProNet-E series servodrives by calculating the load position and compensating.

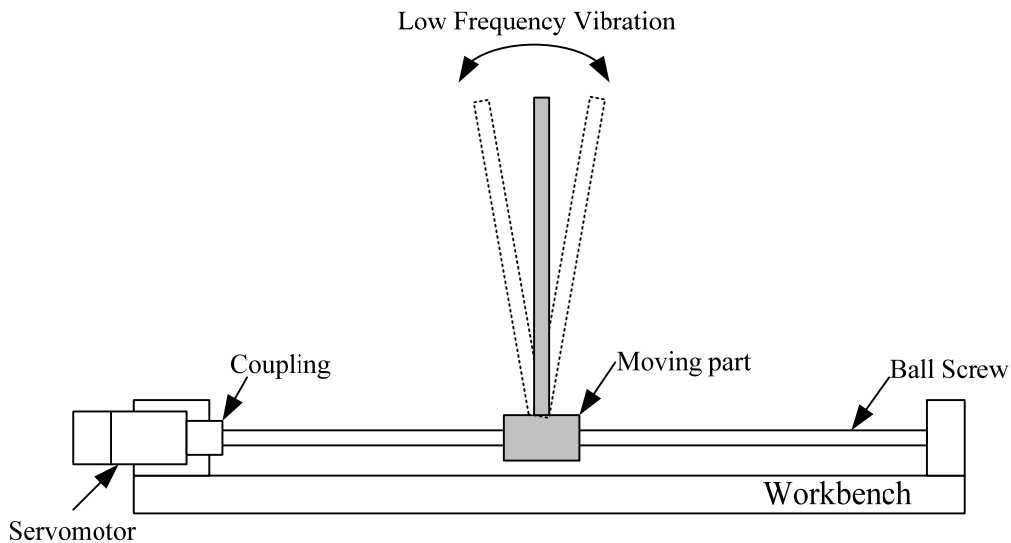

### (2) Application:

Low frequency vibration suppression function is enabled in both speed control mode and position control mode.

Low frequency vibration suppression function is disabled or can not reach the expected effect in the following condition.

- Vibration is picked up due to external force.
- Vibration frequency is out of 5.0Hz to 50.0Hz
- There is mechanical clearance at the mechanical connection part.
- The time for movement is less than one vibration period.

### (3) How to operate:

#### ■ Measuring Vibration frequency

Write the frequency data that measured(unit:0.1Hz) directly to Parameter Pn411, if the vibration frequency can be measured by instrument (such as laser interferometer).And it also can be measured indirectly by communication software ESView or FFT analyse function.



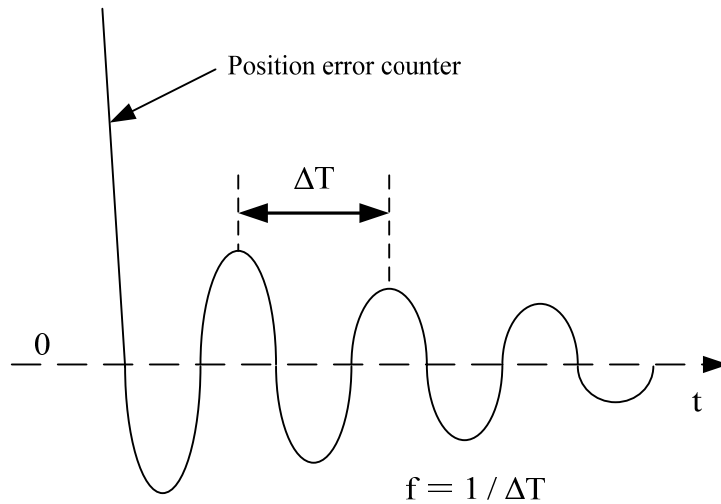

■ Related Parameters

Parameter		Meaning
Pn006	H. □0□□	0:Low frequency vibration suppression function disabled
	H. □1□□	1:Low frequency vibration suppression function enabled

Pn411	<b>Low frequency vibration frequency</b>		<input type="text" value="Speed"/>	<input type="text" value="Position"/>
	<b>Setting Range</b>	<b>Setting Unit</b>	<b>Factory Setting</b>	<b>Setting Validation</b>
	50~500	0.1Hz	100	Immediately
Pn412	<b>Low frequency vibration damp</b>		<input type="text" value="Speed"/>	<input type="text" value="Position"/>
	<b>Setting Range</b>	<b>Setting Unit</b>	<b>Factory Setting</b>	<b>Setting Validation</b>
	0~200	—	25	Immediately

- Writing the frequency data to parameter Pn411 can adjust Pn411 slightly to obtain best suppression effect.
- If the servomotor stopped with continuous vibration, Pn412(Do not change in general) should be increased properly.
- Parameter Pn411 and Pn412 are enabled when Pn006.2=1(Setting validation: after restart).

## 4.5.6 Positioning Completion Output Signal

This signal indicates that servomotor movement has been completed during position control. Use the signal as an interlock to confirm that positioning has been completed at the host controller.

Type	Signal Name	Connector Pin Number	Setting	Meaning
Output	/COIN	CN1-11,CN1-12 (Factory setting)	ON(low level)	Positioning has been completed.
			OFF(high level)	Positioning is not completed.

- This output signal can be allocated to an output terminal with parameter Pn511. Refer to **3.2.2 I/O Signal Names and Functions**.

- The factory setting is allocated to CN1-11,12.

Pn500	Positioning Error			Position
	Setting Range	Setting Unit	Factory Setting	Setting Validation
	0~5000	1Puls	10	Immediately

- The positioning completion (/COIN) signal is output when the difference (position error pulse) between the number of reference pulses output by the host controller and the travel distance of the servomotor is less than the value set in this parameter.
- Set the number of error pulses in reference unit (the number of input pulses defined using the electronic gear).
- Too large a value at this parameter may output only a small error during low-speed operation that will cause the /COIN signal to be output continuously.
- The positioning error setting has no effect on final positioning accuracy.

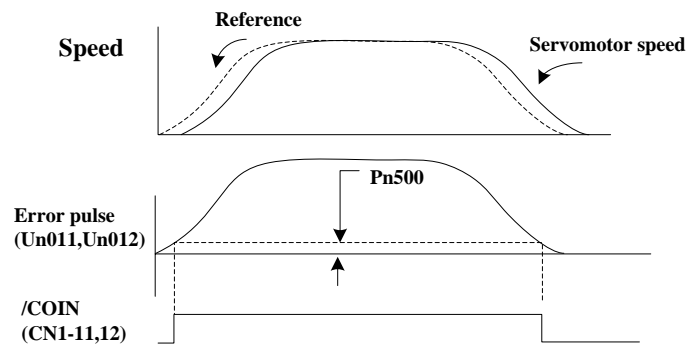

### ■ Note

- /COIN is a position control signal.
- This signal is used for the speed coincidence output /V-CMP for speed control, and it always OFF(high level) for torque control.

## 4.5.7 Reference Pulse Inhibit Function(INHIBIT)

### (1)Description

This function inhibits the servodrive from counting input pulses during position control.

The servomotor remains locked (clamped) while pulses are inhibited.

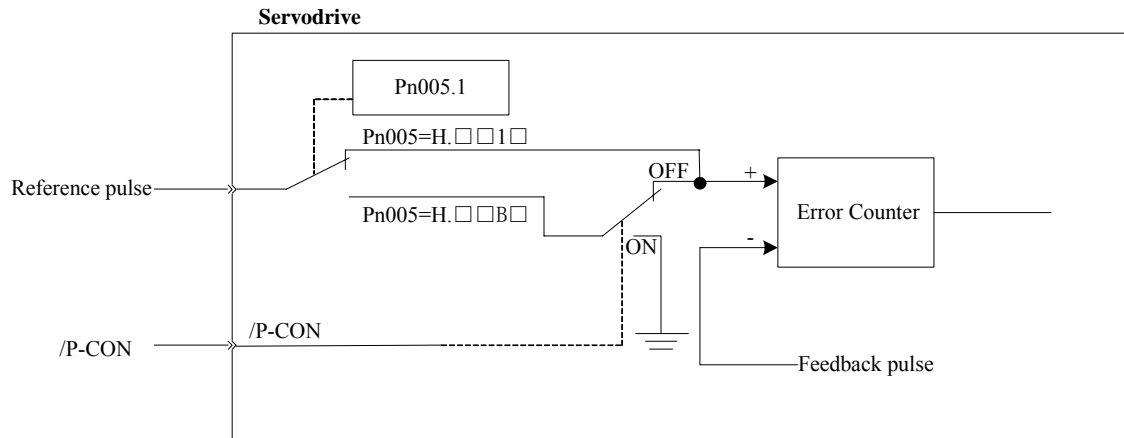

### (2)Setting Parameters

Parameter	Meaning
Pn005	H. □□B□ Control mode selection: position control(pulse train reference)⇔INHIBIT
<p>■ Inhibit(INHIBIT) switching condition</p> <ul style="list-style-type: none"> <li>• /P-CON signal ON (low level)</li> </ul>	
<p>Input reference pulses are not counted during this period.</p> <p><math>t1, t2 \leq 0.5ms</math></p>	

### (3)Setting Input Signals

Type	Signal Name	Connector Pin Number	Setting	Meaning
Input	/P-CON	CN1-15	ON(low level)	Turns the INHIBIT function ON. (Inhibit the servopack from counting reference pulses)
			OFF(high level)	Turns the INHIBIT function OFF. (Counts reference pulses.)

## 4.5.8 Position Control (contact reference)

Position control under contact reference (parameter Pn005.1=C). In this mode, servo drive can position with a single axes without a host controller.

There are 16 position control points with each could set move distance, running speed, constants for position reference filter time and the stop time when positioning completed. Two speeds (1. speed moving towards distance switch “speed of looking for reference point”. 2. Speed moving away from distance switch “moving speed.”) of reference points could be set as:

Two position modes: 1. Absolute position mode 2. Relative position mode

Two running modes: 1. Circling mode 2. Non-circling mode

Two step switching method: 1. Delay step switching 2. /P-CON signal switching

Method of looking for reference points: 1. Forward direction 2. Reverse direction

### ■Adjusting offset

Offset of each points has two correspondent parameters: one unit of the parameter is 【x 10000 reference pulse】 and the other is 【x 1 reference pulse】. Setting range of both parameters is: (-9999----+9999), while offset value equals sum of those two values.

For example:

No.0 offset correspond to parameter Pn600 【x 10000 reference pulse】 and Pn601 【x 1 reference pulse】. Set Pn600 = 100, Pn601=-100.

$$\begin{aligned}\text{No.0 offset value} &= \text{Pn600} \times 10000 \text{ reference pulse} + \text{Pn601} \times 1 \text{ reference pulse} \\ &= 100 \times 10000 \text{ reference pulse} + (-100) \times 1 \text{ reference pulse} \\ &= 999900 \text{ reference pulse}\end{aligned}$$

With the same principle, we can conclude: in order to get the same results, we also can set Pn600 = 99 and Pn601 = 9900.

Thus, we can see when the two parameters are not zero; we can get same result by two ways: one is to set the two parameters both negative or both positive, or one negative the other positive.

### ■Speed

Speed mention here refers to the steady speed during motor running, which is similar to the pulse frequency given from external in ordinary position control. However, this speed has nothing to do with electronic gear; it is just the actual speed of the motor.

### ■Position reference filter time constant

Same as position reference filter time constant Pn204 in common position control.

### ■Time for change steps after desired position reached

Apply internally delay of changing steps to valid parameter Pn681.1.

Time for change steps outputs from positioning completed signal CON/, from Servo ON, or from the time when reference point is found till the Servo performs the program to control position of the point. Such period of time depends on step changing time required by a point number among start point in program.

When running point control program, if error counter is set as “not clear error counter when Servo OFF”, then the error counter might flood. If it does not flood, then the servo drive will probably run at the max. running speed when Servo ON again. **PLEASE PAY ATTENTION TO THE SAFETY OF INSTRUMENT.**

Para. No.	Name and description	Setting range	Default
Pn004.1	[0] Clear error pulse when S-OFF, not clear error pulse when overtravel. [1] Not clear error pulse [2] Clear error pulse When S-OFF or over travel	0~2	0

#### ■Looking for the reference point

Looking for the reference point is for establishing a zero physical point of the operating platform, which is used as zero point in the coordinates during point position control. And users may choose to find a reference point either in forward side or reverse side.

#### How to find a reference point

Mount a limit switch in the forward or reverse side, find a reference point in the forward direction after connect to /PCL and in the reverse direction after connect to /NCL. When the operating platform bump into the limit switch, motor will first stop according to the way set by Pn004.0 and then rotates again against limit switch. When the operating platform leaves the limit switch and the motor reaches the position of first photo encoder Phase C pulse. Then position of operating platform is set to be the zero point of the coordinates.

#### How to find related parameters of reference point

Speed towards limit switch is called “speed of looking for reference point”, and the speed moving away from limit switch is called “moving speed”. These two speeds could be set by following parameters:

Para. No.	Description	Unit	Setting range	Default
Pn685	Speed of looking for reference point (hits the limit switch)	rpm	0~3000	1500
Pn686	Moving speed (move away from limit switch)	rpm	0~200	30

Usually, if the set speed of the reference point (Pn685) is high and the Moving speed (Pn686) is low. Note: if moving speed is too high, precision of finding a reference point would be affected.

Besides, /PCL and /NCL is no longer functioned to limiting external current when looking for a reference point.

■ Related parameter

Para. No.	Description	Observation
Pn681.0	Choose between cycle run and single run. 0: cycle run, /PCL as start signal, /NCL reverse to look for reference point. 1: Single run, /PCL as start signal, /NCL reverse to look for reference point. 2. Cycle run, /NCL as start signal, /PCL reverse to look for reference point. 3. Single run, /NCL as start signal, /PCL reverse to look for reference point.	Changing steps will be performed till the end point completed and the next change will start from the start point during multi-points cycle run, Point control program will not change steps after the end point completed during multi- points single run.
Pn681.1	Change step and start mode 0: Delay changing steps, the start signal is not needed. 1: Change steps by /P-CON, no need of the start signal 2. Delay changing steps, need start signal. 3. Change steps by /P-CON, need start signal	Change steps by external /P-CON signals. The signal will be valid when drive output reaches the desired position. When input signal changes the signal is valid, then steps will be changed by consequence from start point to end point.
Pn681.2	Change step input signal mode [0] High or low level [1] sign pulse	
Pn682	0: Incremental 1: Absolute	Incremental: relative moving distance (distance from current point to next point) programming Absolute: absolute moving distance (distance between operating platform and the reference point) programming.

## 4.5.9 Position Homing Control (Homing Function)

In position control mode, servomotor always need to operate in a fixed position, this position is normally regarded as zero position. When the host controller is turned on, zero position adjustment is required before processing. This zero position will be regarded as the reference point. ESTUN servo drive can perform this by the homing function.

### (1)Homing Mode Setting

Para. No.	Description	
Pn689	b. <input type="checkbox"/> <input type="checkbox"/> <input type="checkbox"/> <input type="checkbox"/> 0	Homing in the forward direction
	b. <input type="checkbox"/> <input type="checkbox"/> <input type="checkbox"/> <input type="checkbox"/> 1	Homing in the reverse direction
	b. <input type="checkbox"/> <input type="checkbox"/> 0 <input type="checkbox"/>	Return to search C-Pulse when homing
	b. <input type="checkbox"/> <input type="checkbox"/> 1 <input type="checkbox"/>	Directly search C-Pulse when homing
	b. <input type="checkbox"/> <input type="checkbox"/> 0 <input type="checkbox"/> <input type="checkbox"/>	Homing function disabled
	b. <input type="checkbox"/> <input type="checkbox"/> 1 <input type="checkbox"/> <input type="checkbox"/>	Homing triggered by SHOM signal(rising edge)
<ul style="list-style-type: none"> <li>• Applicable control mode:position control</li> <li>• Homing operation can only be operated when /COIN is ON.</li> <li>• Pulses sending from the host controller is disabled when homing</li> <li>• Homing operation is disabled when switching control mode,</li> <li>• Control mode switching is not allowed during homing.</li> <li>• After changing these parameters, turn OFF the main circuit and control power supplies and then turn them ON again to enable the new settings.</li> <li>• A parameter can be used to re-allocate input connector number for the SHOM and ORG signals. Refer to <b>3.2.2 I/O Signal Names and Functions</b>.</li> </ul>		

### (2)Related parameter:

Pn685	Speed of finding reference point(Hitting the origin signal ORG)			
	Setting Range	Setting Unit	Factory Setting	Setting Validation
	0~3000	rpm	1500	Immediately
Pn686	Speed of finding reference point(Leaving the origin signal ORG)			
	Setting Range	Setting Unit	Factory Setting	Setting Validation
	0~200	rpm	30	Immediately
Pn690	Number of error pulses during homing			
	Setting Range	Setting Unit	Factory Setting	Setting Validation
	0~9999	10000 pulses	0	Immediately
Pn691	Number of error pulses during homing			
	Setting Range	Setting Unit	Factory Setting	Setting Validation
	0~9999	1 pulse	0	Immediately

### (3)Input Signal Setting

Type	Signal	Connector Pin	Setting	Meaning
Input	SHOM	Must be allocated by Pn509,Pn510	ON= ↑ (rising edge)	Homing is enabled
			OFF(not rising edge)	Homing is disabled
Input	ORG	Must be allocated by Pn509,Pn510	ON=H	ORG is enabled
			OFF=L	ORG is disabled

• After changing Pn509 and Pn510, turn OFF the main circuit and control power supplies and then turn them ON again to enable the new settings.

### Allocating Homing Output Signal (/HOME)

Parameter		Connector Pin Number		Meaning
		+ Terminal	- Terminal	
Pn511	H.□□□8	CN1-11	CN1-12	The signal is output from output terminal CN1-11,12.
Pn511	H.□□8□	CN1-5	CN1-6	The signal is output from output terminal CN1-5,6
Pn511	H.□8□□	CN1-9	CN1-10	The signal is output from output terminal CN1-9,10

• After changing Pn510, turn OFF the main circuit and control power supplies and then turn them ON again to enable the new settings.  
• /HOME signal is only enabled at low level.

### (4)Description of Homing Operation

Please set Pn689 according to the actual operation in position control mode. Starting homing function, the servomotor will run at the speed of Pn685 when detecting the rising edge of SHOM signal; the servomotor will run at the speed of Pn686 according to the setting of Pn689.1 when detecting the valid ORG signal.

When ORG is disabled and detecting encoder C-pulse, servo drive will begin to calculate the number of homing offset pulses. When offset pulses is completed, the servomotor stops and outputs homing completion signal /HOME, then homing control is completed.

Pn685 (Hitting the origin signal (ORG)) is usually set at high speed, Pn686 (Leaving the origin signal ORG) is usually set at low speed.

Please be attention that if Pn686 is setting too high, the precision of mechanical zero position will be affected.

**After hitting the origin signal ORG, the motor will return to find C-pulse; the figure is shown as below:**

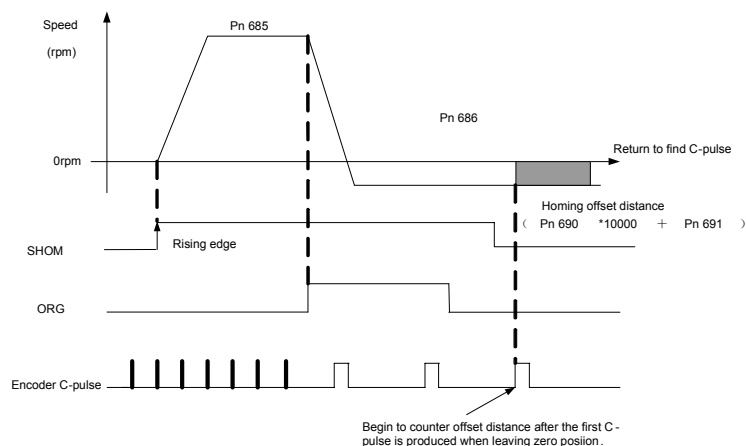



**Corresponding position:**

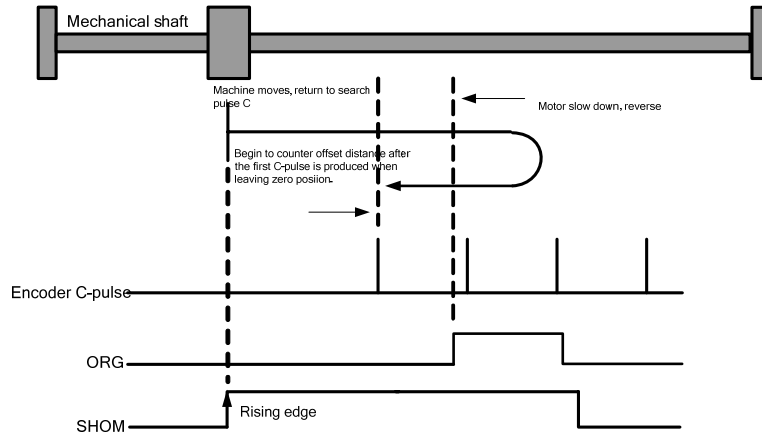

**After hitting the origin signal ORG, the motor will find C-pulse directly; the figure is shown as below:**

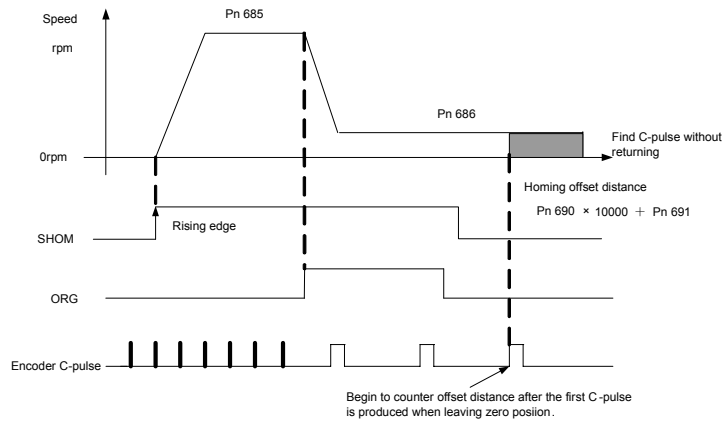

**Corresponding position:**

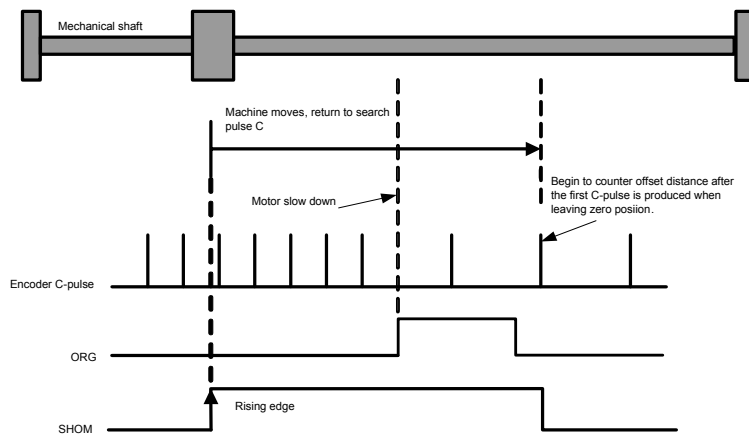

## 4.6 Operating Using Torque Control

### 4.6.1 Setting Parameters

The following parameters must be set for torque control operation with analog voltage reference.

Parameter		Meaning
Pn005	H. □□2□	Control mode selection: Torque control(analog voltage reference)

Pn400	Torque Reference Input Gain				
			Speed	Position	Torque
	Setting Range	Setting Unit	Factory Setting	Setting Validation	
	10~100	0.1V/100%	33	Immediately	

This sets the analog voltage level for the torque reference(T-REF) that is necessary to operate the servomotor at the rated torque.

■ Example

Pn400=30: The servomotor operates at the rated torque with 3V input (factory setting).

Pn400=100: The servomotor operates at the rated torque with 10V input.

Pn400=20: The servomotor operates at the rated torque with 2V input.

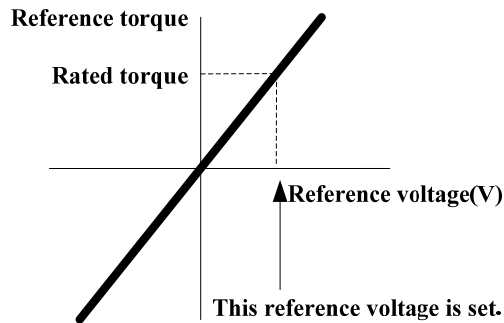

## 4.6.2 Torque Reference Input

By applying a torque reference determined by the analog voltage reference to the servodrive, the servomotor torque can be controlled in proportion with the input voltage.

Type	Signal Name	Connector Pin Number	Meaning
Input	T-REF+	CN1-26	Torque Reference Input
	T-REF-	CN1-27	

Used during torque control (analog voltage reference)

(Pn005.1=2, 6, 8, 9)

The torque reference input gain is set in Pn400. For setting details, refer to **4.6.1 Setting Parameters**.

### ■ Input specifications

- Input range: DC $\pm 0 \sim \pm 10$ V/rated torque
- Factory setting

Pn400=30: Rated torque at 3V

+3V input: Rated torque in forward direction

+9V input: 300% rated torque in forward direction

-0.3V input: 10% rated torque in reverse direction

The voltage input range can be changed with parameter Pn400.

### ■ Input circuit example

Use twisted-pair wires as a countermeasure against noise.

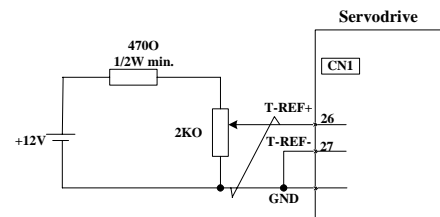
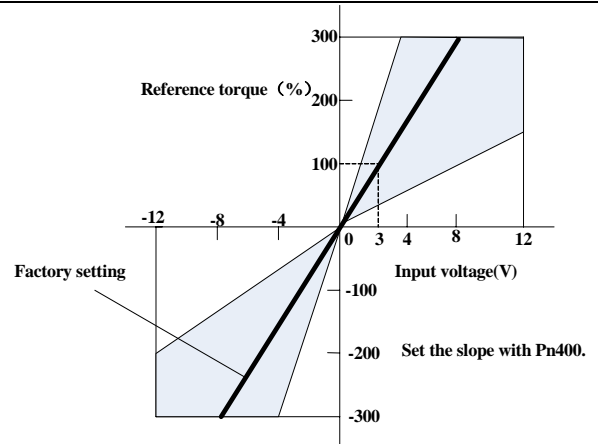

### ■ Checking the internal torque reference

1. Checking the internal torque reference with the panel operator.

Use the Monitor Mode(Un003). Refer to **5.1.6 Operation in Monitor Mode**.

2. Checking the internal torque reference with an analog monitor.

The internal torque reference can also be checked with an analog monitor.

## 4.6.3 Adjusting the Reference Offset

### (1) Automatic Adjustment of the Torque Reference Offset

When using torque control, the servomotor may rotate slowly even when 0V is specified as the analog reference voltage. This occurs when the host controller or external circuit has a slight offset (measured in mv) in the reference voltage. In this case, the reference offset can be adjusted automatically and manually using the panel operator.

The automatic adjustment of analog(speed,torque) reference offset(Fn003) automatically measures the offset and adjusts the reference voltage.

The servodrive performs the following automatic adjustment when the host controller or external circuit has an offset in the reference voltage.

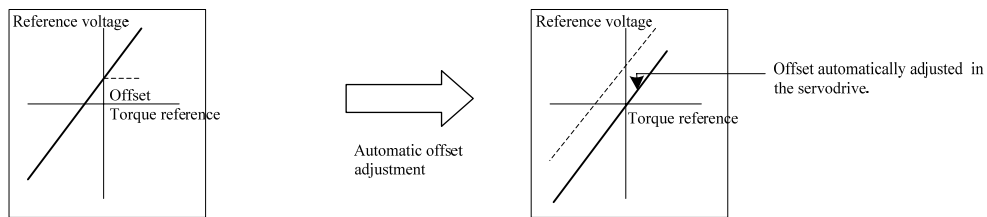

After completion of the automatic adjustment, the amount of offset is stored in the servodrive. The amount of offset can be checked in the manual adjustment of torque reference offset(Fn004).

The automatic adjustment of analog reference offset(Fn003) cannot be used when a position loop has been formed with the host controller and the error pulse is changed to zero at the servomotor stop due to servolock.

Use the torque reference offset manual adjustment(Fn004).

---

#### Note:

The analog reference offset must be automatically adjusted with the servo OFF.

---

### (2) Manual Adjustment of the Torque Reference Offset

Manual adjustment of the torque reference offset(Fn004) is used in the following cases.

- If a position loop is formed with the host controller and the error is zeroed when servolock is stopped.
- To deliberately set the offset to some value.
- Use this mode to check the offset data that was set in the automatic adjustment mode of the torque reference offset.

This mode operates in the same way as the automatic adjustment mode(Fn003), except that the amount of offset is directly input during the adjustment.

The offset adjustment range and setting unit are as follows.

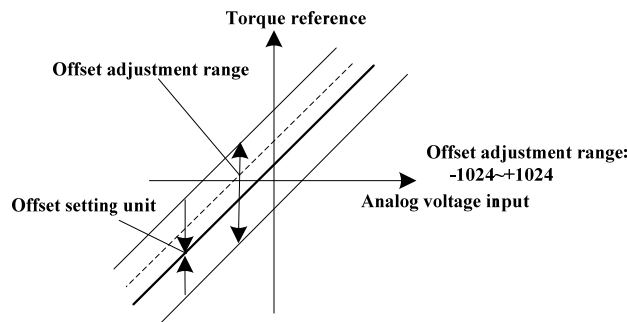

## 4.6.4 Limiting Servomotor Speed During Torque Control

During torque control, the servomotor is controlled to output the specified torque, which means that the servomotor speed is not controlled. Accordingly, when an excessive reference torque is set for the mechanical load torque, it will prevail over the mechanical load torque and the servomotor speed will greatly increase.

This function serves to limit the servomotor speed during torque control to protect the machine.

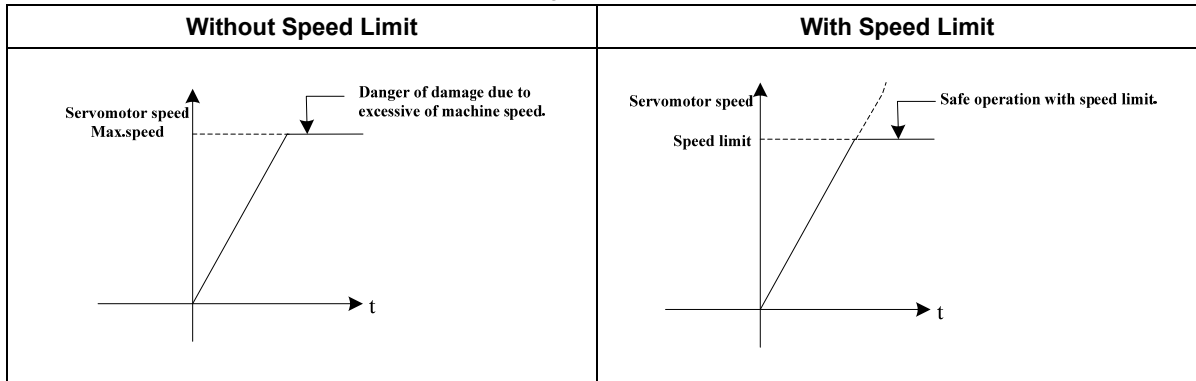

### (1)Speed Limit Enable

Parameter		Description
Pn001	b. □□0□	Use the value set in Pn406 as the speed limit (internal speed limit function)
	b. □□1□	Use V-REF as an external speed limit input. Applies a speed limit using the input voltage of V-REF and the setting in Pn300(external speed limit function).

### (2)Speed Limit During Torque Control

Pn406	Speed Limit During Torque Control			
				Torque
	<b>Setting Range</b>	<b>Setting Unit</b>	<b>Factory Setting</b>	<b>Setting Validation</b>
	0~6000	rpm	1500	Immediately
<ul style="list-style-type: none"> <li>• Set the servomotor speed limit value during torque control.</li> <li>• The setting in this parameter is enabled when Pn001=b.□□0□.</li> <li>• The servomotor's maximum speed will be used when the setting in this parameter exceeds the maximum speed of the servomotor used.</li> </ul>				

### (3)External Speed Limit Function

Type	Signal Name	Connector Pin Number	Name
Input	V-REF+	CN1-1	External Speed Limit Input
	V-REF-	CN1-2	

- Inputs an analog voltage reference as the servomotor speed limit value during torque control.
- The smaller value is enabled, the speed limit input from V-REF or the Pn406 (speed limit during torque control) when Pn005=H.□□1□.
- The setting in Pn300 determines the voltage level to be input as the limit value. Polarity has no effect.

Pn300	Speed Reference Input Gain			Speed	Position	Torque
	Setting Range	Setting Unit	Factory Setting	Setting Validation		
	0~3000	rpm/v	150	Immediately		

- Set the voltage level for the speed that is to be externally limited during torque control.
- With Pn300=150(factory setting) and 6V input from V-REF(CN1-1,2), the actual servomotor speed is limited to the rated speed of the servomotor used.

## 4.7 Operating Using Speed Control with an Internally Set Speed

The function of internally set speed selection allows speed control operation by externally selecting an input signal from among seven servomotor speed setting made in advance with parameters in the servodrive. The speed control operations within the three settings are valid. There is no need for an external speed or pulse generator.

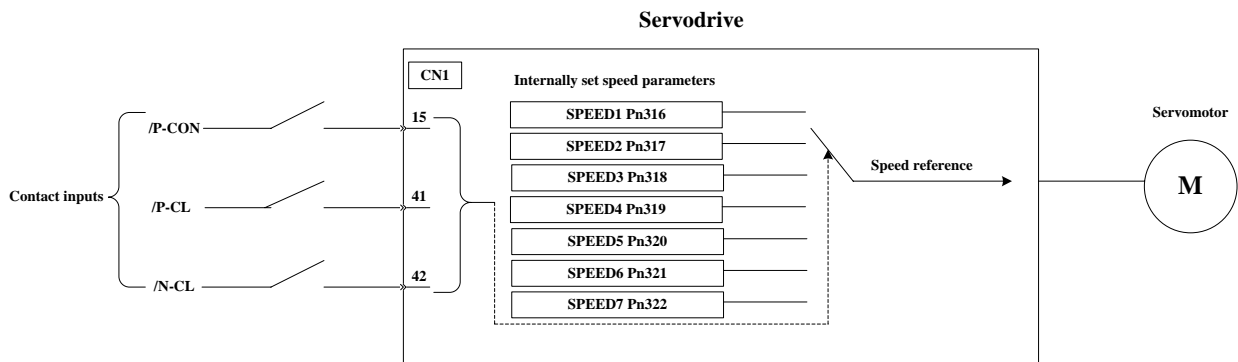

## 4.7.1 Setting Parameters

Parameter		Meaning
Pn005	H. □□3□	Control mode selection: Speed control(contact reference) ↔ Speed control(zero reference)

Pn316	Internal set speed 1			speed
	<b>Setting Range</b>	<b>Setting Unit</b>	<b>Factory Setting</b>	<b>Setting Validation</b>
	-6000~6000	rpm	100	Immediately
Pn317	Internal set speed 2			speed
	<b>Setting Range</b>	<b>Setting Unit</b>	<b>Factory Setting</b>	<b>Setting Validation</b>
	-6000~6000	rpm	200	Immediately
Pn318	Internal set speed 3			speed
	<b>Setting Range</b>	<b>Setting Unit</b>	<b>Factory Setting</b>	<b>Setting Validation</b>
	-6000~6000	rpm	300	Immediately
Pn319	Internal set speed 4			speed
	<b>Setting Range</b>	<b>Setting Unit</b>	<b>Factory Setting</b>	<b>Setting Validation</b>
	-6000~6000	rpm	-100	Immediately
Pn320	Internal set speed 5			speed
	<b>Setting Range</b>	<b>Setting Unit</b>	<b>Factory Setting</b>	<b>Setting Validation</b>
	-6000~6000	rpm	-200	Immediately
Pn321	Internal set speed 6			speed
	<b>Setting Range</b>	<b>Setting Unit</b>	<b>Factory Setting</b>	<b>Setting Validation</b>
	-6000~6000	rpm	-300	Immediately
Pn322	Internal set speed 7			speed
	<b>Setting Range</b>	<b>Setting Unit</b>	<b>Factory Setting</b>	<b>Setting Validation</b>
	-6000~6000	rpm	500	Immediately

(Note):The servomotor's maximum speed will be used whenever a speed setting for the Pn316~Pn322 exceeds the maximum speed.

## 4.7.2 Input Signal Settings

The following input signals are used to switch the operating speed.

Type	Signal Name	Connector Pin Number	Meaning
Input	/P-CON	CN1-15	Selects the internally set speed.
Input	/P-CL	CN1-41	Selects the internally set speed.
Input	/N-CL	CN1-42	Selects the internally set speed.

## 4.7.3 Operating Using an Internally Set Speed

Use ON/OFF combinations of the following input signals to operate with the internally set speeds.

When Pn005.1=3: Selects the internally set speed (contact reference)  $\longleftrightarrow$  Speed control (zero reference)

Input Signal			Speed
/P-CON	/P-CL	/N-CL	
OFF(H)	OFF(H)	OFF(H)	Speed control (zero reference)
	OFF(H)	ON(L)	SPEED1
	ON(L)	OFF(H)	SPEED2
	ON(L)	ON(L)	SPEED3
ON(L)	OFF(H)	OFF(H)	SPEED4
	OFF(H)	ON(L)	SPEED5
	ON(L)	OFF(H)	SPEED6
	ON(L)	ON(L)	SPEED7

Note: OFF= High level; ON= Low level

### ■ Control Mode Switching

When Pn005.1 = 4, 5, 6, and either /P-CL or /N-CL is OFF (high level), the control mode will switch.

#### Example:

When Pn005.1=5: Speed control(contact reference)  $\longleftrightarrow$  Position control (pulse train)

Input Signal			Speed
/P-CON	/P-CL	/N-CL	
OFF(H)	OFF(H)	OFF(H)	Pulse train reference input (position control)
	OFF(H)	ON(L)	SPEED1
	ON(L)	OFF(H)	SPEED2
	ON(L)	ON(L)	SPEED3
ON(L)	OFF(H)	OFF(H)	SPEED4
	OFF(H)	ON(L)	SPEED5
	ON(L)	OFF(H)	SPEED6
	ON(L)	ON(L)	SPEED7



## 4.7.4 Limiting Servomotor Speed During Torque Control

During torque control, the servomotor is controlled to output the specified torque, which means that the servomotor speed is not controlled. Accordingly, when an excessive reference torque is set for the mechanical load torque, it will prevail over the mechanical load torque and the servomotor speed will greatly increase.

This function serves to limit the servomotor speed during torque control to protect the machine.

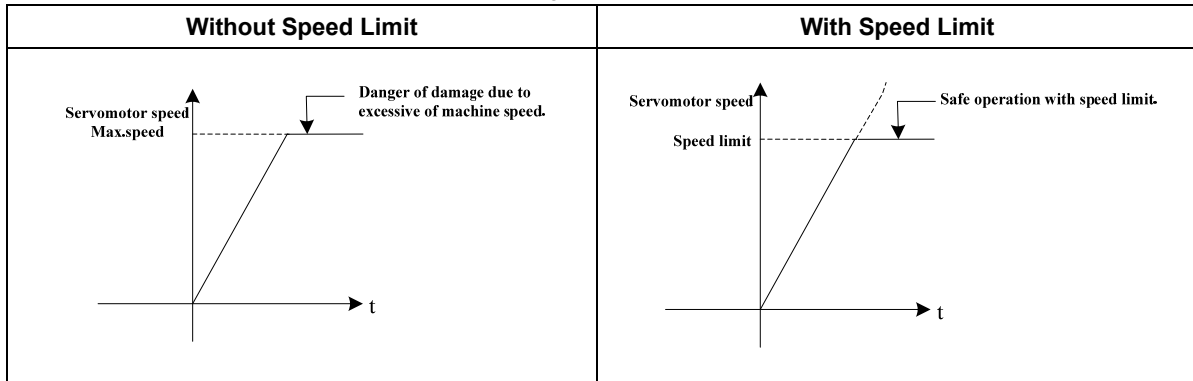

### (1)Speed Limit Enable

Parameter		Description
Pn001	b. <input type="checkbox"/> <input type="checkbox"/> <input type="checkbox"/> <input type="checkbox"/>	Use the value set in Pn406 as the speed limit (Internal speed limit)
	b. <input type="checkbox"/> <input type="checkbox"/> <input type="checkbox"/> <input type="checkbox"/>	Use the lower speed between V-REF and Pn406 as an external speed limit input.(External speed limit)

### (2)Internal Speed Limit Fuction

Pn406	Speed Limit During Torque Control			
	Torque			
	Setting Range	Setting Unit	Factory Setting	Setting Validation
0~6000	rpm	1500	Immediately	

- Set the servomotor speed limit value during torque control.
- Pn005=H. , Pn406 is motor speed limit value.
- The servomotor's maximum speed will be used when the setting in this parameter exceeds the maximum speed of the servomotor used.

### (3)External Speed Limit Function

Type	Signal Name	Connector Pin Number	Name
Input	V-REF+	CN1-1	External Speed Limit Input
	V-REF-	CN1-2	

- Inputs an analog voltage reference as the servomotor speed limit value during torque control.
- The smaller value is enabled, the speed limit input from V-REF or the Pn406 (speed limit during torque control) when Pn005=H. .
- The setting in Pn300 determines the voltage level to be input as the limit value. Polarity has no effect.

Pn300	Speed Reference Input Gain				
			Speed	Position	Torque
	Setting Range	Setting Unit	Factory Setting	Setting Validation	
0~3000	rpm/v	150	Immediately		

- Set the voltage level for the speed that is to be externally limited during torque control.

## 4.8 Limiting Torque

The servodrive provides the following three methods for limiting output torque to protect the machine.

NO.	Limiting Method	Reference Section
1	Internal torque limit	4.8.1
2	External torque limit	4.8.2
3	Torque limiting by analog voltage reference	4.8.3

### 4.8.1 Internal Torque Limit

Maximum torque is always limited to the values set in the following parameters.

Pn401	Forward Torque Limit		Speed	Position	Torque
	<b>Setting Range</b>	<b>Setting Unit</b>	<b>Factory Seeting</b>	<b>Setting Validation</b>	
	0~300	1%	300	Immediately	
Pn402	Reverse Torque Limit		Speed	Position	Torque
	<b>Setting Range</b>	<b>Setting Unit</b>	<b>Factory Seeting</b>	<b>Setting Validation</b>	
	0~300	1%	300	Immediately	

- The setting unit is a percentage of rated torque.
- The maximum torque of the servomotor is used, even though the torque limit is set higher than the maximum torque of the servomotor. (as is the case with the 300% factory setting)

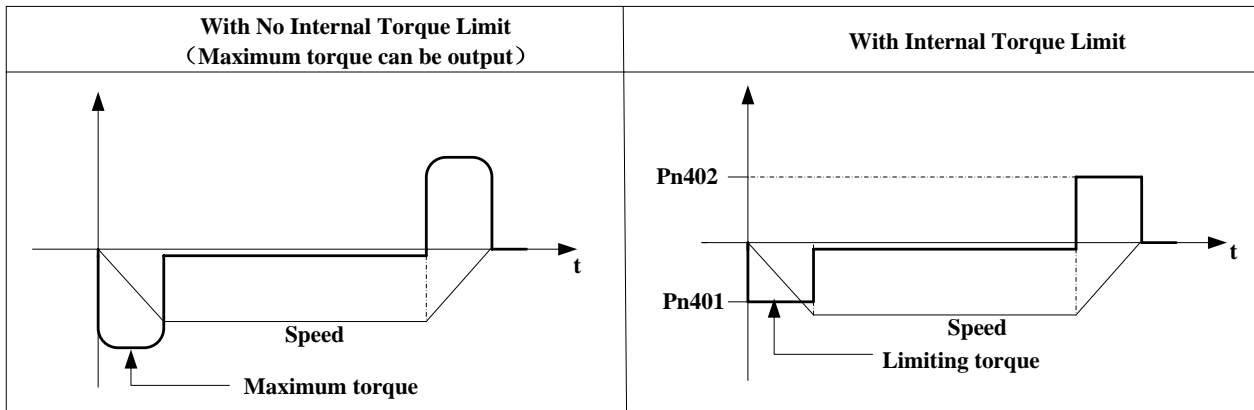

■ Note:

Too small a torque limit setting will result in insufficient torque during acceleration and deceleration.

## 4.8.2 External Torque Limit

This function allows the torque to be limited at specific times during machine operation, for example, during press stops and hold operations for robot workpieces.

An input signal is used to enable the torque limits previously set in parameters.

### (1)Related Parameters

Pn403	Forward External Torque Limit			Speed	Position	Torque
	<b>Setting Range</b>	<b>Setting Unit</b>	<b>Factory Setting</b>	<b>Setting Validation</b>		
	0~300	1%	100	Immediately		
Pn404	Reverse External Torque Limit			Speed	Position	Torque
	<b>Setting Range</b>	<b>Setting Unit</b>	<b>Factory Setting</b>	<b>Setting Validation</b>		
	0~300	1%	100	Immediately		

Note: The setting unit is a percentage of rated torque (i.e., the rated torque is 100%).

### (2)Input Signals

Type	Signal Name	Connector Pin Number	Setting	Meaning	Limit Value
Input	/P-CL	CN1-41 (factory setting)	ON(low level)	Forward external torque limit	Pn403
			OFF(high level)	Forward internal torque limit	Pn401
Input	/N-CL	CN1-42 (factory setting)	ON(low level)	Reverse external torque limit	Pn404
			OFF(high level)	Reverse internal torque limit	Pn402

When using this function, make sure that there are no other signals allocated to the same terminals as /P-CL and /N-CL.

### (3)Changes in Output Torque during External Torque Limiting

Example: External torque limit (Pn401, Pn402) set to 300%

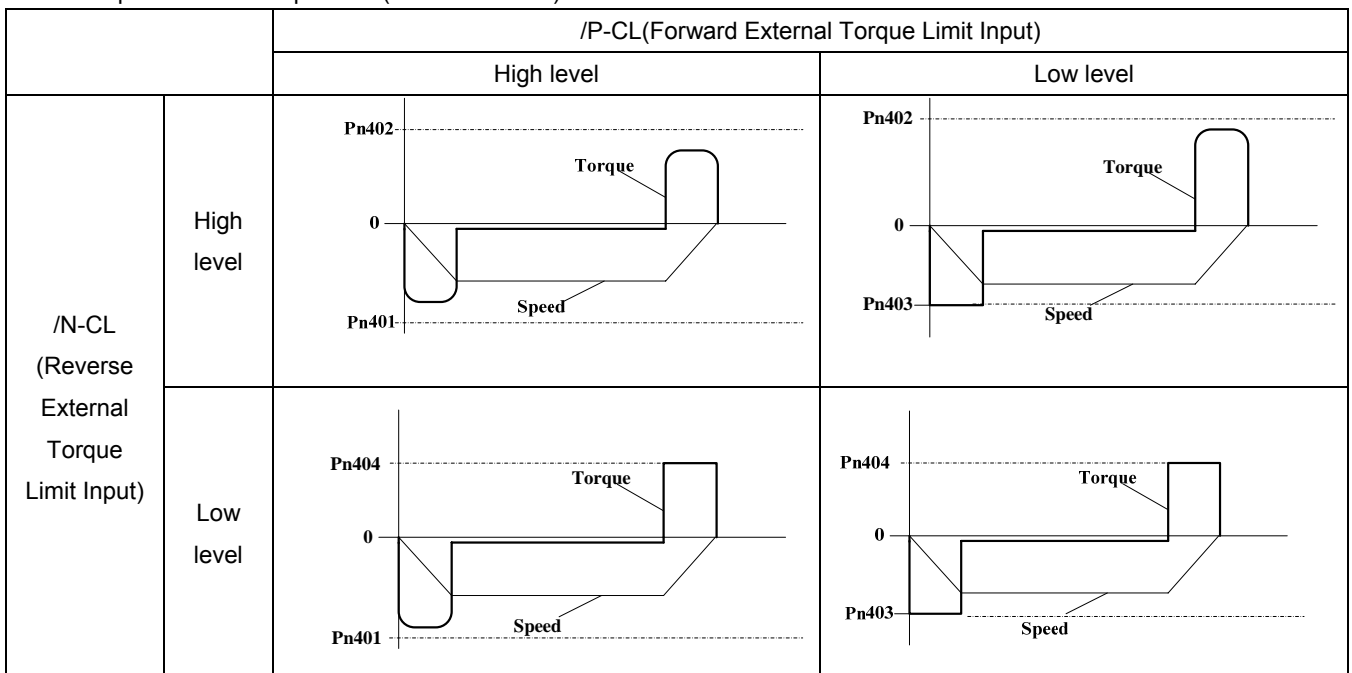

Note: Select the servomotor rotation direction by setting Pn001=b.    0 (standard setting, CCW=Forward direction).

### 4.8.3 Torque Limiting Using an Analog Voltage Reference

Torque limiting by analog voltage reference limits torque by assigning a torque limit in an analog voltage to the T-REF terminals (CN1-26,27). This function can be used only during speed or position control, not during torque control.

Refer to the following block diagram when the torque limit with an analog voltage reference is used for speed control.

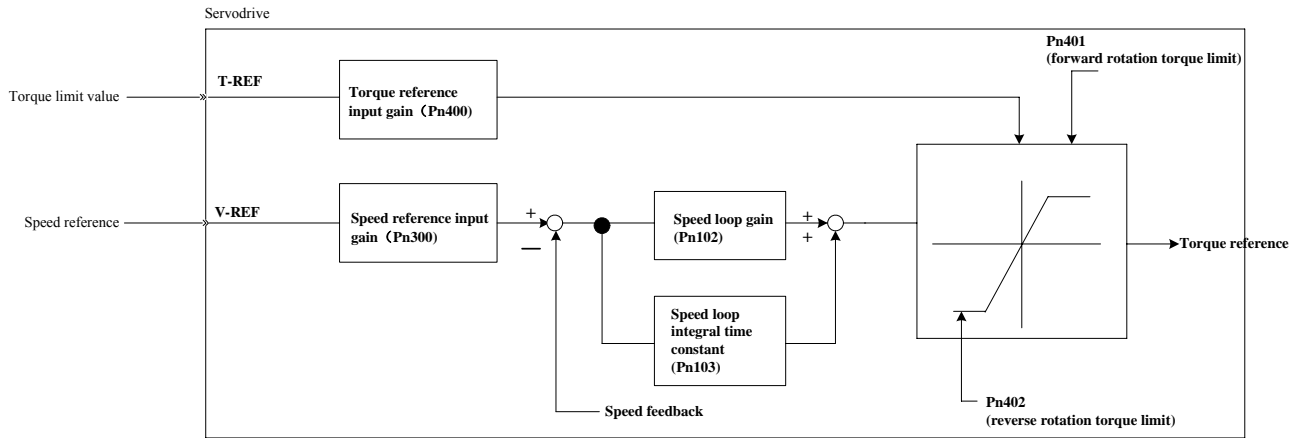

**Important:**

- There is no polarity in the input voltage of the analog voltage reference for torque limiting.
- The absolute values of both + and – voltages are input, and a torque limit value corresponding to that absolute value is applied in the forward or reverse direction.

**Related Parameters**

Parameter	Meaning
Pn001      b. □1□□	Use the T-REF terminal to be used as an external torque limit input.

## 4.9 Control Mode Selection

The methods and conditions for switching servodrive control modes are described below.

### 4.9.1 Setting Parameters

The following combinations of control modes can be selected according to the application of customers.

Parameter		Control Method
Pn005	H. □□4□	Speed control(contact reference) ↔ Speed control(analog voltage reference)
	H. □□5□	Speed control(contact reference) ↔ Position control(pulse train reference)
	H. □□6□	Speed control(contact reference) ↔ Torque control(analog voltage reference)
	H. □□7□	Position control(pulse train reference) ↔ Speed control(analog voltage reference)
	H. □□8□	Position control(pulse train reference) ↔ Torque control(analog voltage reference)
	H. □□9□	Torque control(analog voltage reference) ↔ Speed control(analog voltage reference)
	H. □□A□	Speed control(analog voltage reference) ↔ Zero clamp
	H. □□B□	Position control(pulse train reference) ↔ Position control(inhibit)

### 4.9.2 Switching the Control Mode

Switching Speed Control(Pn005.1=4, 5, 6)

With the sequence input signals in the factory setting, the control mode will switch when both /P-CL and /N-CL signals are OFF (high level).

Type	Signal Name	Connector Pin Number	Setting	Meaning
Input	/P-CL	CN1-41(factory setting)	OFF(high level)	Switches control mode.
Input	/N-CL	CN1-42(factory setting)	OFF(high level)	

## 4.10 Other Output Signals

### 4.10.1 Servo alarm output

The following diagram shows the right way to connect Alarm Output.

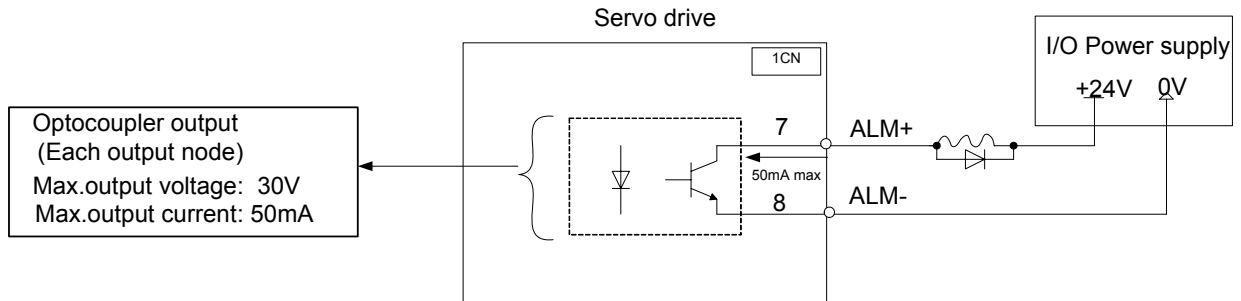

External +24V I/O power supply is required, since there is no +24V power supply available inside servo drive.

Output → ALM+	1CN- 7	Servo alarm output
Output → ALM-	1CN- 8	Servo alarm output uses grounding signal

The signal outputs when servodrive is detected abnormal.

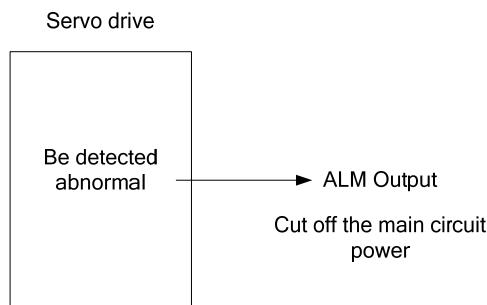

Normally, the external circuit consists of /ALM should be able to switch off power of servo drive.

Signal	Status	Output level	Comments
ALM	ON	1CN-7: "L" level	Normal state
	OFF	1CN-8: "H" level	Alarm state

When "servo alarm(ALM)" happens, always remove alarm reasons first, and then turn the input signal "/ALM-RST" to ON position to reset alarm status.

→ Input	/ALM-RST	1CN- 39	alarm reset input
---------	----------	---------	-------------------

Signal	Status	Input level	Comments
/ALM-RST	ON	1CN-39: "L" level	Reset servo alarm
	OFF	1CN-39: "H" level	Do not reset servo alarm

Normally, the external circuit can switch off power supply of servo drive when alarm occurs. When servo drive is re-switched on, it removes alarm automatically, so normally alarm reset signal is not required to be connected.

In addition, alarm reset are enabled with panel operator.

**Note: When alarm occurs, always remove alarm reasons before resetting alarms.**

## 4.10.2 Rotation Detection Output Signal(/TGON)

Type	Signal Name	Connector Pin Number	Setting	Meaning
Output	/TGON	CN1-5,CN1-6 (Factory setting)	ON(low level)	Servomotor is operating(Servomotor speed is above the setting in Pn503).
			OFF(high level)	Servomotor is not operating(Servomotor speed is below the setting in Pn503).
This signal is output to indicate that the servomotor is currently operating above the setting in parameter Pn503.				

### • Related parameter

Pn503	Rotation Detection Speed TGON			
		Speed	Position	Torque
	<b>Setting range</b>	<b>Setting unit</b>	<b>Factory setting</b>	<b>Setting validation</b>
	0~3000	rpm	20	Immediately
<ul style="list-style-type: none"> <li>• Sets the range in which the rotation detection output signal (/TGON) is output in this parameter.</li> <li>• When the servomotor rotation speed is above the value set in the Pn503, it is judged that servomotor rotation speed signal (/TGON) is output.</li> <li>• The rotation detection signal can also be checked on the panel operator.</li> </ul>				

## 4.10.3 Servo Ready(/S-RDY) Output

Type	Signal Name	Connector Pin Number	Setting	Meaning
Output	/S-RDY	CN1-9,CN1-10 (factory setting)	ON(low level)	Servo is ready.
			OFF(high level)	Servo is not ready.
<ul style="list-style-type: none"> <li>• This signal indicates that the servodrive received the servo ON signal and completed all preparations.</li> <li>• It is output when there are no servo alarms and the main circuit power supply is turned ON.</li> </ul>				

## 4.10.4 Encoder C Pluse Output (/PGC)

Type	Signal Name	Connector Pin Number	Setting	Meaning
Output	/PGC	Not including this setting in the default setting, please choose terminal output by setting parameter Pn511	ON(low level)	With encoder C pluse output
			OFF(high level)	Without encoder C pluse output
This signal indicates that when servodrive circumrotate to position of C pluse, there is a correlation between the width of C pluse and the speed of servodrive.				

### 4.10.5 Over travel signal output(OT)

Type	Signal Name	Connector Pin Number	Setting	Meaning
Output	OT	Not including this setting in the default setting,please choose terminal output by setting parameter Pn511	ON(low level)	Without forward rotation prohibited(POT) and reverse rotation prohibited(NOT)signal
			OFF(high level)	With forward rotation prohibited(POT) and reverse rotation prohibited(NOT)signal
When machine is on over travel state,OT signal is OFF;Host controller can use this signal to stop sending reference.				

#### Related parameter

Pn000	POT/NOT			
		Speed	Position	Torque
	<b>Setting Range</b>	<b>Unit</b>	<b>Factory Setting</b>	<b>Setting Validation</b>
	0~1111	—	0	After restart
Pn000.1=1,external POT disabled;Pn000.2=1, external NOT disabled; Pn000.1=1 and Pn000.2=1,OT signal is ON.				

### 4.10.6 Servo Enabled Motor Excitation Output(/RD)

Type	Signal Name	Connector Pin Number	Setting	Meaning
Output	/RD	Not including this setting in the default setting,please choose terminal output by setting parameter Pn511	ON=L	Servo enabled motor excitation
			OFF=H	Servo disabled motor not excitation
/RD is on when servo enabled motor excitation.				

### 4.10.7 Torque Limit Detection Output (/CLT)

The application of output signal /CLT is as follows:

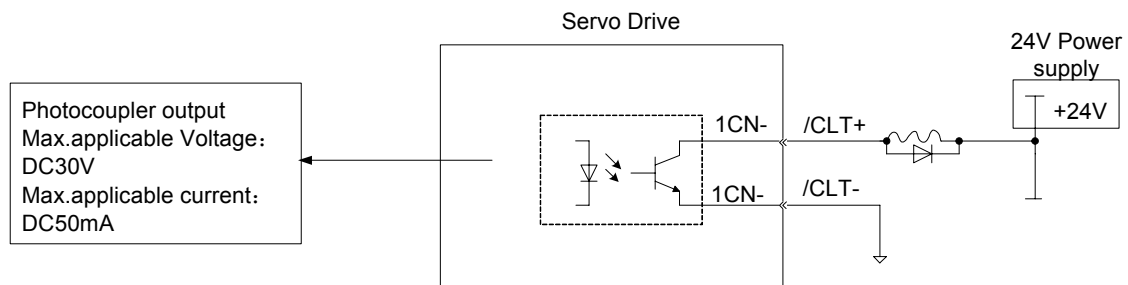

—>Output /CLT	Torque limit output	Speed, torque control, position control
---------------	---------------------	-----------------------------------------



Indicates the output torque (current) of motor is limited.

Type	Signal Name	Connector Pin Number	Setting	Meaning
Output	/CLT	Not including this setting in the default setting, please choose terminal output by setting parameter Pn511	ON=L	Motor output torque under limit (Internal torque reference is higher than setting value )
			OFF=H	No torque limit (Internal torque reference is lower than setting value )

Please use the following user constants to define output signals and pins when using /CLT signal.

Para. No.		Connector Pin Number		Meaning
		+Terminal	-Terminal	
Pn511	H.□□□3	CN1-11	CN1-12	Output signal of CN1-11, CN1-12 is /CLT
Pn511	H.□□3□	CN1-05	CN1-06	Output signal of CN1-5, CN1-6 is /CLT
Pn511	H.□3□□	CN1-09	CN1-10	Output signal of CN1-9, CN1-10 is /CLT

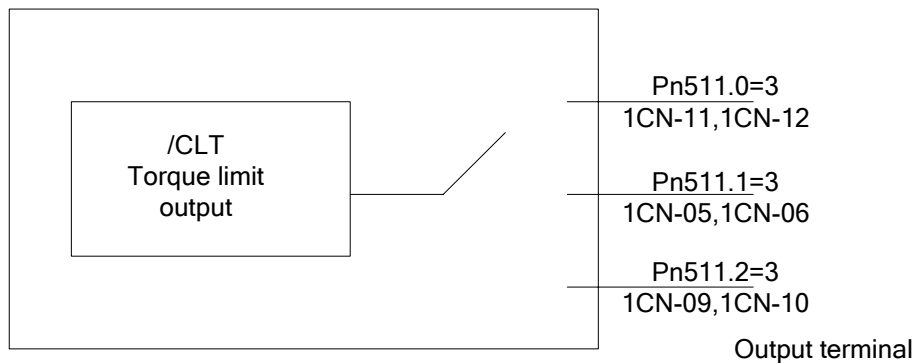

Parameter Pn511 description as following:

0	/COIN(/V-CMP)output
1	/TGON rotation detecting output
2	/S-RDY servo drive get ready output
3	/CLT torque limit output
4	/BK brake interlock output
5	/PGC encoder C pulse output
6	OT overtravel signal output
7	/RD servo enabled motor excitation output
8	/HOME home completion output

## 4.11 Online Autotuning

### 4.11.1 Online Autotuning

Online autotuning calculates the load moment of inertia during operation of the servo drive and sets parameters so that the servo gains consistent with the machine rigidity are achieved.

Online autotuning may not be effective in the following cases.

- The motor high speed is lower than 100 rpm
- The motor acceleration or deceleration is lower than 5000rpm/s
- Load rigidity is low and mechanical vibration occurs easily or friction is high.
- The speed load moment is changed greatly
- Mechanical gas is very large.

If the condition meets one of the above cases or the desired operation cannot be achieved by the online autotuning, set the value in Pn106 (Load inertia percentage) and perform the adjustment manually.

### 4.11.2 Online Autotuning Procedure

 **WARNING**

- Do not perform extreme adjustment or setting changes causing unstable servo operation. Failure to observe this warning may result in injury and damages to the machine.
- Adjust the gains slowly while confirming motor operation.

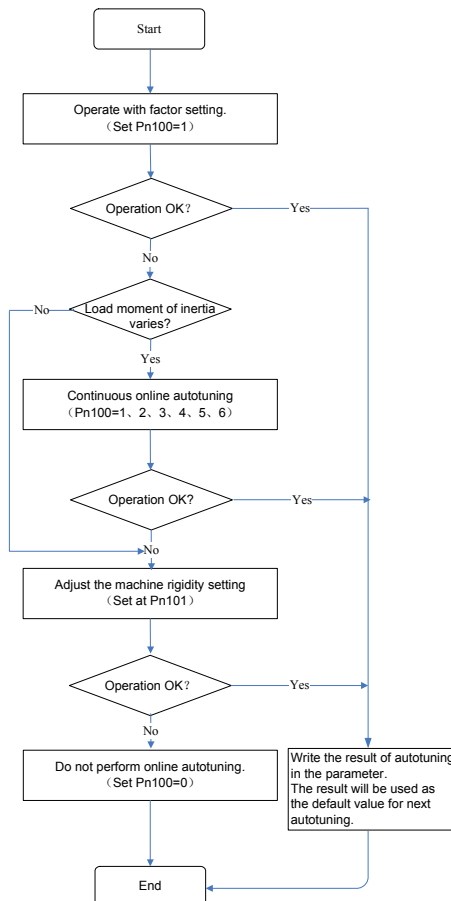

### 4.11.3 Setting Online Autotuning

Related parameters:

Parameter No.	Name	Unit	Setting Range	Factory Setting	Setting Invalidation
Pn100	<b>Online autotuning setting</b> 0:Manual gain adjustment 1,2,3=Normal mode;4,5,6=Vertical load 1,4 = Load inertia without variation; 2,5 = Load inertia with little variation; 3,6=Load inertia with great variation	—	0~6	1	After restart
Pn101	<b>Machine rigidity setting</b>	—	0~15	5	Immediately
Pn128	<b>Speed gain acceleration relationship during online autotuning</b> If the setting is greater, the servo gain will increase.	—	0~3	3	Immediately

### 4.11.4 Machine Rigidity Setting for Online Autotuning

There are 16 machine rigidity settings for online autotuning. When the machine rigidity setting is selected, the servo gains (speed loop gain, speed loop integral time constant, position loop gain) are determined automatically. The factory setting for the machine rigidity setting is 5.

Machine Rigidity Setting	Position Loop Gain 【s <sup>-1</sup> 】 Pn104	Speed Loop Gain 【Hz】 Pn102=Pn104*( Pn128+1)	Speed Loop Integral Time Constant 【0.1ms】 Pn103
0	10	40	800
1	15	60	600
2	20	80	450
3	25	100	400
4	30	120	300
5	40	160	200
6	65	260	140
7	80	320	110
8	100	400	90
9	120	480	80
10	140	560	70
11	160	640	60
12	180	720	55
13	210	840	50
14	250	1000	40
15	300	1200	30

## Panel Operator

### 5.1 Basic Operation

#### 5.1.1 Functions on Panel Operator

Panel operator is a built-in operator that consists of display part and keys located on the front panel of the servodrive. Parameter setting, status display and execution of utility function are enabled using the panel operator. The names and functions of the keys on the panel operator are shown as follows.

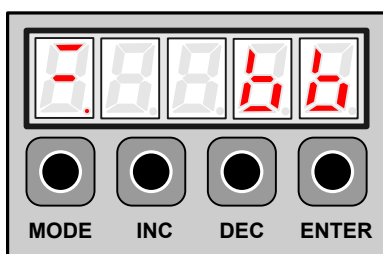

Panel Symbol	Corresponding Key Name	Function
▲	INC key	<ul style="list-style-type: none"> <li>To display the parameter settings and setting values.</li> <li>To increase the setting value.</li> </ul>
▼	DEC key	<ul style="list-style-type: none"> <li>To decrease the setting value.</li> </ul>
M	MODE key	<ul style="list-style-type: none"> <li>To select a basic mode, such as the display mode, parameter setting mode, monitor mode or utility function mode.</li> <li>To save the setting during parameter setting and exit.</li> </ul>
◀	ENTER key	To display the parameter settings and setting values, and release alarm.

**Note:** In this manual, the Panel Symbol is represented by Corresponding Key Name for easy understanding.

#### 5.1.2 Resetting Servo Alarms

Servo alarms can be reset by pressing the ENTER key when the panel operator in display mode. Servo alarms can also be reset the CN1-39(/ALM-RST) input signal.

There is no need to clear the servo alarms if it turns the main circuit power supply OFF.

**Note:** After an alarm occurs, remove the cause of the alarm before resetting it.

### 5.1.3 Basic Mode Selection

The basic modes include status display mode, parameter setting mode, monitor mode, and utility function mode. Each time the MODE key is pressed, the next mode in the sequence is selected.

Select a basic mode to display the operation status, set parameters and operation references.

The basic mode is selected in the following order.

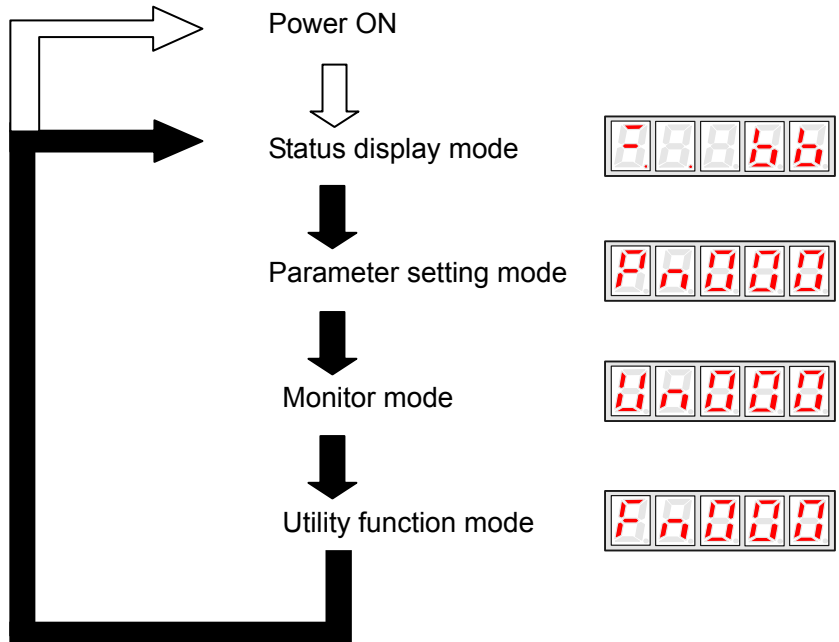

### 5.1.4 Status Display Mode

The status display mode displays the servodrive status as bit data and codes.

#### Selecting Status Display Mode

The status display mode is selected when the power supply is turned ON. If it is not displayed, select this mode by pressing MODE key.



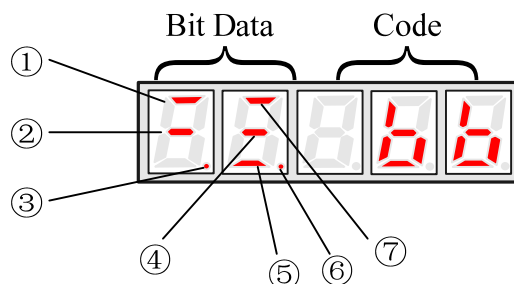

Note that the display differs between the speed/torque control and position control types.



■ Bit Data Display

No.	Speed/Torque Control Mode		Position Control Mode	
	Bit Data	Description	Bit Data	Description
①	Speed Coincidence	Lit when the difference between the servomotor and reference speed is the same as or less than the preset value. Preset value:Pn501(factory setting is 10rpm ) Always lit in torque control mode.	Positioning Completion	Lit if error between position reference and actual servomotor position is below preset value. Preset value:Pn500(10 pulse is factory setting)
②	Base lock	Lit for base block. Not lit at servo ON.	Base block	Lit for base block. Not lit at servo ON.
③	Control power ON	Lit when servodrive control power is ON.	Control power ON	Lit when servodrive control power is ON.
④	Speed reference input	Lit if input speed reference exceeds preset value.Not lit if input speed reference is below preset value. Preset value: Pn503(factory setting is 20 rpm)	Reference pulse input	Lit if reference pulse is input. Not lit if no reference pulse is input.
⑤	Torque reference input	Lit if input torque reference exceeds preset value. Not lit if input torque reference is below preset value. Preset value: 10% of rated torque	Error counter clear signal input	Lit when error counter clear signal is input. Not lit when error counter clear signal is not input.
⑥	Power ready	Lit when main circuit power supply is ON and normal. Not lit when main circuit power supply is OFF.	Power ready	Lit when main circuit power supply is ON and normal. Not lit when main circuit power supply is OFF.
⑦	Rotation detection /TGON	Lit if servomotor speed exceeds preset value.Not lit if servomotor speed is below preset value. Preset value: Pn503(factory setting is 20 rpm)	Rotation detection /TGON	Lit if servomotor speed exceeds preset value.Not lit if servomotor speed is below preset value. Preset value: Pn503(factory setting is 20 rpm)

■ Codes Display

Code	Meaning
	Baseblock Servo OFF(servomotor power OFF)
	Run Servo ON (servomotor power ON)
	Forward Run Prohibited CN1-16 (P-OT) is OFF.
	Reverse Run Prohibited CN1-17 (N-OT) is OFF.
	Alarm Status Displays the alarm number.

Press ENTER key to clear the present servo alarm.

## 5.1.5 Operation in Parameter Setting Mode

The servodrive offers a large number of functions, which can be selected or adjusted by the parameter settings. Refer to **A.1 Parameter List** for details.

### ■ Parameter Setting Procedures

The parameter settings can be used for changing parameter data. Before changing the data, check the permitted range of the parameter.

The example below shows how to change parameter Pn102 from “100” to “85”.

1. Press MODE key to select the parameter setting mode.



2. Press INC key or DEC key to select parameter number.

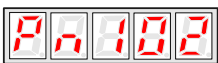

3. Press ENTER key to display the current data of Pn102.

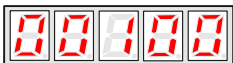

4. Press the INC or DEC key to change the data to the desired number 00085. Hold the key to accelerate the changing of value. When the maximum value or minimum value is reached, pressing INC or DEC key will have no effect.



5. Press the ENTER or MODE key once to return to the display of Pn102.



In addition, press MODE and ENTER keys at the same time to enter into parameter number shifting status to modify parameter number, and then execute the same action to exit parameter number shifting status.

In step 3 and 4, press the ENTER key for longer time to enter into parameter shifting status to modify parameter, and then press the MODE key to save and exit or press the ENTER key to return to parameter number display.

## 5.1.6 Operation in Monitor Mode

The monitor mode allows the reference values input into the servodrive, I/O signal status, and servodrive internal status to be monitored.

### ■ Using the Monitor Mode

The example below shows how to display 1500, the contents of monitor number Un001.

1. Press MODE key to select the monitor mode.



2. Press the INC or DEC key to select the monitor number to display.



3. Press the ENTER key to display the data for the monitor number selected at step 2.



4. Press the ENTER key once more to return to the monitor number display.





## ■ List of Monitor Modes

### Contents of Monitor Mode Display

Monitor Number	Monitor Display	
Un000	Actual servomotor speed Unit: rpm	
Un001	Input speed reference Unit:rpm	
Un002	Input torque reference Unit:% (with respect to rated torque)	
Un003	Internal torque reference Unit:% (with respect to rated torque)	
Un004	Number of encoder rotation angle pulses	
Un005	Input signal monitor	→
Un006	Encoder signal monitor	→
Un007	Output signal monitor	→
Un008	Frequency given by pulse Unit:1kHz	
Un009	Number of servomotor rotation pulses	
Un010	Pulse rate of servomotor rotated ( $\times 10^4$ )	
Un011	Error pulse counter lower 16 digit	
Un012	Error pulse counter higher 16 digit	
Un013	Number of pulses given	
Un014	Number of pulses given ( $\times 10000$ )	
Un015	Load inertia percentage	
Un016	Servomotor overload ratio	

Internal status bit display

7 6 5 4 3 2 1 0



Contents of Bit Display:

Monitor Number	Display LED Number	Content
Un005	0	/S-ON (CN1-14)
	1	/PCON (CN1-15)
	2	P-OT (CN1-16)
	3	N-OT (CN1-17)
	4	/ALM-RST (CN1-39)
	5	/CLR (CN1-40)
	6	/PCL (CN1-41)
	7	/NCL (CN1-42)

Monitor Number	Display LED Number	Content
Un006	0	(Not used)
	1	(Not used)
	2	(Not used)
	3	Phase-C
	4	Phase-B
	5	Phase-A
	6	(Not used)
	7	(Not used)

Monitor Number	Display LED Number	Content
Un007	0	CN1_05, CN1_06
	1	CN1_07, CN1_08
	2	CN1_09, CN1_10
	3	CN1_11, CN1_12

## 5.2 Operation in Utility Function Mode

In utility function mode, the panel operator can be used to run and adjust the servodrive and servomotor.

The following table shows the parameters in the utility function mode.

Parameter No.	Function
Fn000	Alarm traceback data display
Fn001	Parameter setting initialization
Fn002	JOG mode operation
Fn003	Automatic adjustment of speed reference offset
Fn004	Manual adjustment of speed reference offset
Fn005	Automatic adjustment of servomotor current detection
Fn006	Manual adjustment of servomotor current detection
Fn007	Software version display
Fn008	Position teaching
Fn009	Static inertia detection

### 5.2.1 Alarm Traceback Data Display

The alarm traceback display can display up to 10 previously occurred alarms. The alarm is displayed on Fn000, which is stored in the alarm traceback data.

Follow the procedures below to confirm alarms which have been generated.

1. Press the MODE key to select the utility function mode.
2. Press the INC or DEC key to select the function number of alarm trace back data display.



3. Press the ENTER key once, the latest alarm data is displayed.

Alarm Sequence Number    Alarm Code

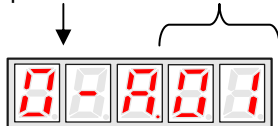

4. Press the INC or DEC key to display other alarms occurred in recent.

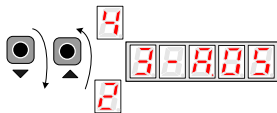

5. Press the ENTER key, the display will return to Fn000.



**Note:** Hold the ENTER key for one second with alarm code displaying, all the alarm traceback datas will be cleared.



## 5.2.2 Parameter Settings Initialization

Follow the procedures below to execute the parameter settings initialization.

1. Press the MODE key to select the utility function mode.
2. Press the INC or DEC key to select the function number of parameter settings initialization.



3. Press the ENTER key to enter into parameter settings mode.



4. Hold the ENTER key for one second, the parameters will be initialized.

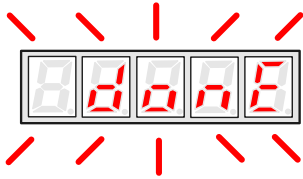

5. Release the ENTER key to return to the utility function mode display Fn001.



---

**Note:**

Press the ENTER key during servo ON does not initialize the parameter settings.  
Initialize the parameter settings with the servo OFF.

---

## 5.2.3 Operation in JOG Mode

Follow the procedures below to operate the servomotor in JOG mode.

1. Press the MODE key to select the utility function mode.
2. Press the INC or DEC key to select the function number of JOG mode operation.



3. Press the ENTER key to enter into JOG operation mode.



4. Press the MODE key to enter into servo ON (servomotor power ON) status.



5. Press the MODE key to switch between the servo ON and servo OFF status. The servodrive must be in servo ON status when the servomotor is running.
6. Press the INC or DEC key to rotate the servomotor.

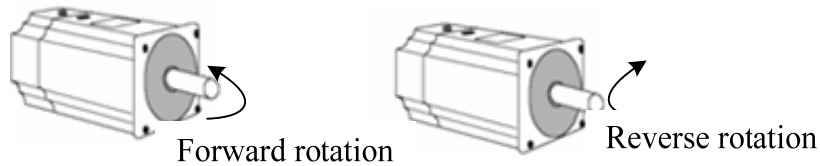

7. Press the ENTER key to return to utility function mode display Fn002. Now the servo is OFF (servomotor power OFF).



## 5.2.4 Automatic Adjustment of the Speed Reference Offset

When using the speed/torque (analog reference) control, the servomotor may rotate slowly even if 0V is specified as the analog voltage reference.

This happens if the host controller or external circuit has a slight offset (in the unit of mV) in the reference voltage.

The reference offset automatic adjustment mode automatically measures the offset and adjusts the reference voltage. It can adjust both speed and torque reference offset.

The servodrive automatically adjusts the offset when the host controller or external circuit has the offset in the reference voltage.

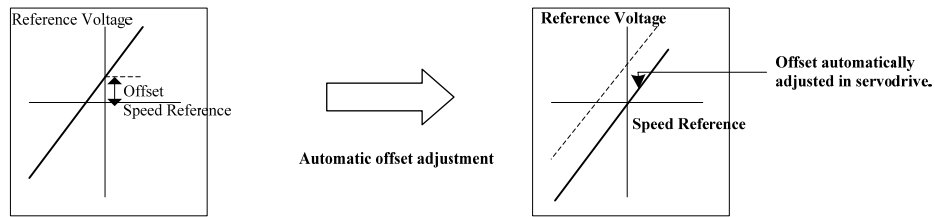

After completion of the automatic adjustment, the amount of offset is stored in the servodrive. The amount of offset can be checked in the speed reference offset manual adjustment mode (Fn004). Refer to **4.4.3 (2) Manual Adjustment of the Speed Reference Offset**.

The automatic adjustment of reference offset (Fn003) cannot be used when a position loop has been formed with a host controller and the error pulse is changed to zero at the servomotor stop due to servolock. Use the speed reference offset manual adjustment for a position loop.

The zero-clamp speed control function can be used to force the servomotor to stop while the zero speed reference is given.

**Note:** The speed reference offset must be automatically adjusted with the servo OFF.

Adjust the speed reference offset automatically in the following procedure.

1. Turn OFF the servodrive and input the 0V reference voltage from the host controller or external circuit.

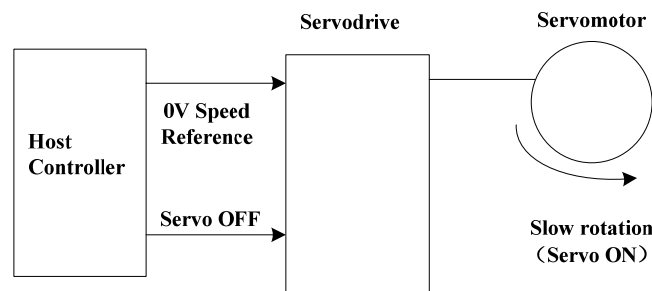

2. Press the MODE key to select the utility function mode.
3. Press the INC or DEC key to select the utility function number Fn003.



4. Press the ENTER key to enter into the speed reference offset automatic adjustment mode.



5. Press the MODE key for more than one second, the reference offset will be automatically adjusted.

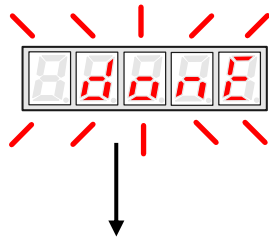

6. Press ENTER key to return to the utility function mode display Fn003.

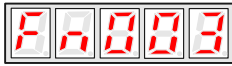

7. Thus, the speed reference offset automatic adjustment is completed.

## 5.2.5 Manual Adjustment of the Speed Reference Offset

Manual adjustment of the speed/torque reference offset is used in the following cases.

- If a position loop is formed with the host controller and the error is zeroed when servolock is stopped.
- To deliberately set the offset to some value.

Use this mode to check the offset data that was set in the automatic adjustment mode of the speed/torque reference offset.

This mode operates in the same way as the automatic adjustment mode, except that the amount of offset is directly input during the adjustment.

The offset adjustment range and setting unit are as follows.

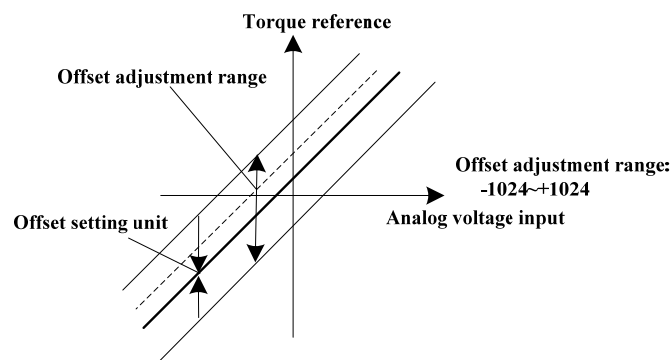

Note:

When the offset using in automatic adjustment exceeds manual adjustment range (-1024~+1024), manual adjustment will be invalid.

Adjust the analog reference offset manually in the following procedure.

1. Press the MODE key to select the utility function mode.
2. Press the INC or DEC key to select the utility function number Fn004.



3. Press the ENTER key to enter into the speed reference offset manual adjustment mode.



4. Turn ON the servo-ON signal, the display is shown as follows:



5. Hold the ENTER key for one second, the speed reference offset will be displayed.

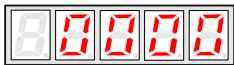

6. Press the INC or DEC key to change the offset.

7. Hold the ENTER key for one second to return to the display in step 4.

8. Press ENTER key to return to the utility function mode display Fn004..



Thus, the speed reference offset manual adjustment is completed.

## 5.2.6 Offset-adjustment of Servomotor Current Detection Signal

Automatic servomotor current detection offset adjustment has performed at ESTUN before shipping. Basically, the user need not perform this adjustment.

Perform this adjustment only if highly accurate adjustment is required for reducing torque ripple caused by current offset.

This section describes the automatic and manual servomotor current detection offset adjustment.

---

### Note:

- Offset-adjustment of the servomotor current detection signal is possible only while power is supplied to the main circuit power supply and with the servo is OFF.
  - Execute the automatic offset adjustment if the torque ripple is too big when compared with that of other servodrives.
  - If this function, particularly manual adjustment, is executed carelessly, it may worsen the characteristics.
- 

### ■ Automatic Offset-adjustment of Servomotor Current Detection Signal

Adjust the servomotor current detection signal automatically in the following procedure.

1. Press the MODE key to select the utility function mode.

2. Press the INC or DEC key to select the utility function number Fn005.



3. Press the ENTER key to enter into the automatic adjustment of the servomotor current detection signal mode.



4. Press the MODE key, the display will blinks for one second. The offset will be automatically adjusted.

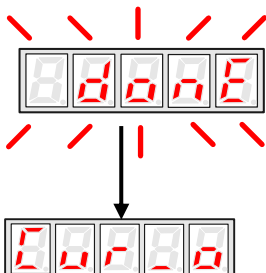

5. Press the ENTER key to return to the utility function mode display Fn005.





Thus, the automatic offset-adjustment of the servomotor current detection signal is completed.

### ■ Manual Offset-adjustment of Servomotor Current Detection Signal

Adjust the servomotor current detection signal manually in the following procedure.

1. Press the MODE key to select the utility function mode.
2. Press the INC or DEC key to select the utility function number Fn006.



3. Press the ENTER key to enter into the manual adjustment of the servomotor current detection signal mode.

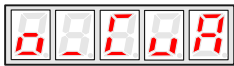

4. Press the MODE key to switch between the phase U(o \_ CuA) and phase V(1\_ Cub) servomotor current detection offset adjustment.

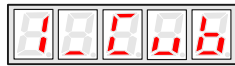
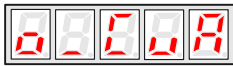

5. Hold the ENTER key for one second to display the phase V offset amount.

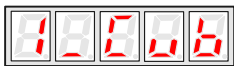

6. Press the INC or DEC key to adjust the offset.



7. Press the ENTER key for one second to return to the display in step 3 or 4.
8. Press the ENTER key to return to the utility function mode display Fn006.



Thus, the manual offset-adjustment of the servomotor current detection signal is completed.

---

**Note:**

The adjusting range of the servomotor current detection offset is -1024 to +1024.

---

## 5.2.7 Software Version Display

Set the Fn007 to select the software version check mode to check the servodrive software version.

1. Press the MODE key to select the utility function mode.
2. Press the INC or DEC key to select the utility function number Fn007.



3. Press the ENTER key to display the DSP software version (the highest bit displays d or E or F or 0).

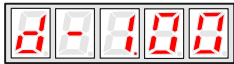

4. Press the MODE key to display the FPGA/CPLD software version (the highest bit displays P).



5. Press the MODE key to return to DSP software version display.
6. Press the ENTER key to return to the utility function mode display Fn007.

## 5.2.8 Position Teaching Function

Perform the position teaching function in the following procedure.

1. Press the MODE key to select the utility function mode.
2. Press the INC or DEC key to select the utility function number Fn008.

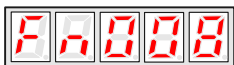

3. Press the ENTER key, the display will be shown as below.



4. Press the ENTER key, the display will be shown as below.

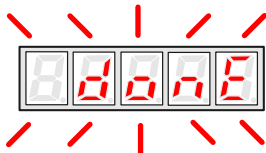

5. Release the ENTER key to complete position teaching function.

## 5.2.9 Static Inertia Detection

1. Press the MODE key to select the utility function mode.
2. Press the INC or DEC key to select the utility function number Fn009.



3. Press the ENTER key, the display will be shown as below.



4. Press the MODE key to rotate the servomotor, and the servomotor dynamic speed will be displayed.
5. The unit of the servomotor and load total inertia displayed when servomotor stops is kg.cm<sup>2</sup>

Thus, the static inertia detection is completed.

---

**Note:** Make sure that the servomotor has 6 circles travel displacement in the CCW direction at least before detection.

---

## MODBUS Communication

### 6.1 RS-485 Communication Wiring

ProNet-E series servodrives provide the MODBUS communication function with RS-485 interface, which can be used to easily set parameters or to perform monitoring operations and so on.

The definitions of the servodrive communication connector terminals are as follows.

CN3:

Terminal No.	Name	Function
1	—	Reserved
2	—	
3	485+	RS-485 communication terminal
4	ISO_GND	Isolated ground
5	ISO_GND	
6	485-	RS-485 communication terminal
7	CANH	CAN communication terminal
8	CANL	CAN communication terminal

Note: Do not short terminal 1 and 2 of CN3.

CN4:

Terminal No.	Name	Function
1	—	Reserved
2	—	Reserved
3	485+	RS-485 communication terminal
4	ISO_GND	Isolated ground
5	ISO_GND	
6	485-	RS-485 communication terminal
7	CANH	CAN communication terminal
8	CANL	CAN communication terminal

Note:

1. The length of the cable should be less than 100 meters in a less disturbed environment. However, if transmission speed is above 9600bps, please use the communication cable within 15 meters to ensure the accuracy of transmission.
2. A maximum of 31 servodrives can be connected when RS485 is used. Terminating resistances are used at both ends of the 485 network. If more devices are wanted to connect, use the repeaters to expand.
3. CN3 of servodrive is always used as communication cable input terminal, and CN4 is always used as communication cable output terminal (If still need to connect slave stations, the communication cable is connected from CN4 terminal to the next slave station; if need not, add balance resistor in CN4 terminal). It is prohibited to connect CN3 of any two servodrives directly when multiple ProNet-E series servodrives are connected.

**Example:**

When RS-485 network is composed of a PLC and A、 B、 C three servodrives, the cable wiring is shown as follows:  
 PLC→CN3 of A, CN4 of A→CN3 of B, CN4 of B→CN3 of C, CN4 of C→120Ω terminating resistance.

## 6.2 MODBUS Communication Related Parameters

Parameter No.	Description	Setting Validation	Control Mode	Meaning
Pn700	Hex	After restart	ALL	<b>Pn700.0 MODBUS baud rate</b> [0] 4800bps [1] 9600bps [2] 19200bps <b>Pn700.1 Communication protocol selection</b> [0] 7, N, 2 (MODBUS,ASCII) [1] 7, E, 1 (MODBUS,ASCII) [2] 7, O, 1 (MODBUS,ASCII) [3] 8, N, 2 (MODBUS,ASCII) [4] 8, E, 1 (MODBUS,ASCII) [5] 8, O, 1 (MODBUS,ASCII) [6] 8, N, 2 (MODBUS,RTU) [7] 8, E, 1 (MODBUS,RTU) [8] 8, O, 1 (MODBUS,RTU) <b>Pn700.2 Communication protocol selection</b> [0] SCI communication with no protocol [1] MODBUS SCI communication <b>Pn700.3 Reserved</b>
Pn701	Axis address	After restart	ALL	Axis address of MODBUS protocol communication

## 6.3 MODBUS Communication Protocol

MODBUS communication protocol is only used when Pn700.2 is set to 1. There are two modes for MODBUS communication: ASCII (American Standard Code for information interchange) mode and RTU (Remote Terminal Unit) mode.

The next section describes the two communication modes.

### 6.3.1 Code Meaning

#### ASCII Mode:

Every 8-bit data is consisted by two ASCII characters. For example: One 1-byte data 64 H (Hexadecimal expression) is expressed as ASCII code '64', which contains '6' as ASCII code 36<sub>H</sub> and '4' as ASCII code 34<sub>H</sub>.

ASCII code for number 0 to 9、character A to F are as follows:

Character	'0'	'1'	'2'	'3'	'4'	'5'	'6'	'7'
ASCII Code	30 <sub>H</sub>	31 <sub>H</sub>	32 <sub>H</sub>	33 <sub>H</sub>	34 <sub>H</sub>	35 <sub>H</sub>	36 <sub>H</sub>	37 <sub>H</sub>
Character	'8'	'9'	'A'	'B'	'C'	'D'	'E'	'F'
ASCII Code	38 <sub>H</sub>	39 <sub>H</sub>	41 <sub>H</sub>	42 <sub>H</sub>	43 <sub>H</sub>	44 <sub>H</sub>	45 <sub>H</sub>	46 <sub>H</sub>

#### RTU Mode:

Every 8-bit data is consisted by two 4-bit hexadecimal data, that is to say, a normal hexadecimal data. For example: decimal data 100 can be expressed as 64<sub>H</sub> by 1-byte RTU data.

Data Structure:

#### 10-bit character form (7-bit data)

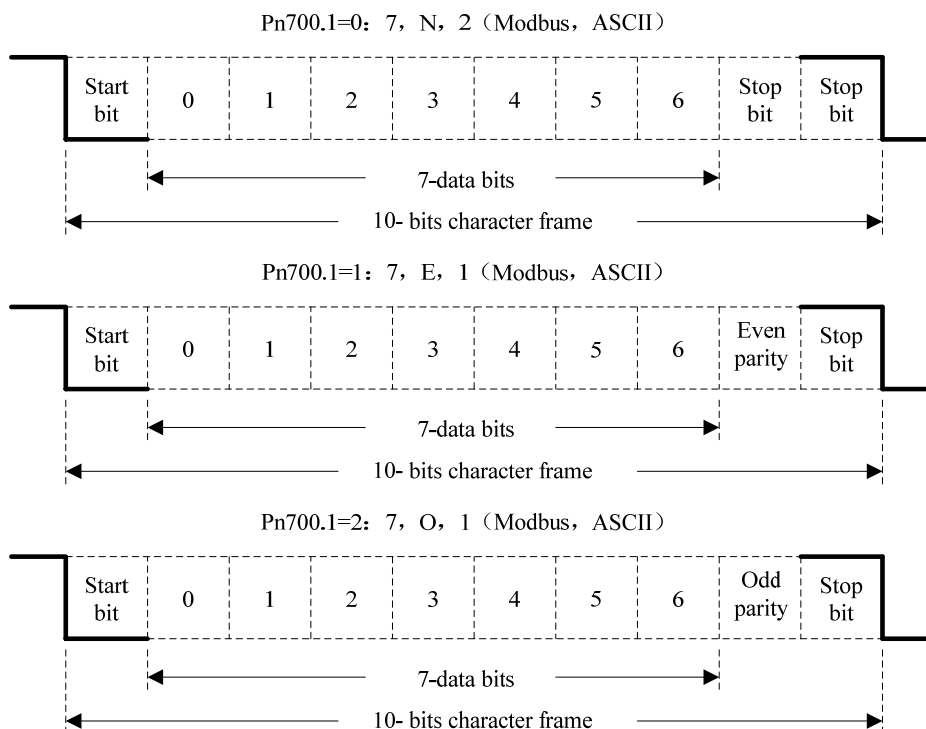

**11-bit character form (8-bit data)**

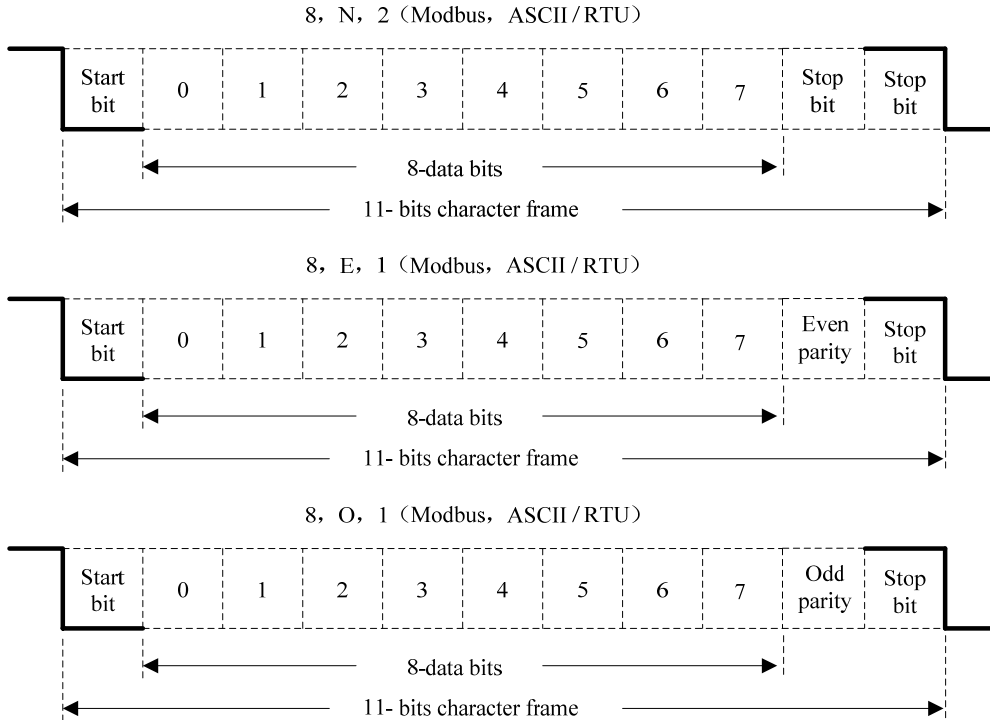

Communication protocol structure:

Data format of communication protocol:

**ASCII Mode:**

STX	Start character: ' => (3A <sub>H</sub> )
ADR	Communication address => 1-byte contains two ASCII codes
CMD	Reference code => 1-byte contains two ASCII codes
DATA(n-1)	Data content => n-word=2n-byte contain 4n ASCII codes, n ≤ 12
.....	
DATA(0)	
LRC	Checking code => 1-byte contains two ASCII codes
End 1	End code 1 => (0D <sub>H</sub> ) (CR)
End 0	End code 0 => (0A <sub>H</sub> ) (LF)

**RTU Mode:**

STX	Sleep interval of at least 4 bytes transmission time.
ADR	Communication address => 1-byte
CMD	Reference code => 1-byte
DATA(n-1)	Data content => n-word=2n-byte, n ≤ 12
.....	
DATA(0)	
CRC	CRC checking code => 1-byte
End 1	Sleep interval of at least 4 bytes transmission time.

Communication protocol data format instructions are as follows:

**STX (communication start)**

ASCII mode: ':' character

RTU mode: Sleep interval of at least 4 bytes transmission time (automatically changed according to different communication speed) .

**ADR (communication address)**

Valid communication address: 1 to 254

For example: communicate with the servodrive which address is 32 (20 in hex):

ASCII mode: ADR='2', '0'=>'2'=32<sub>H</sub>, '0'=30<sub>H</sub>

RTU mode: ADR=20<sub>H</sub>

**CMD (command reference) and DATA (data)**

Data structure is determined by command code. Regular command code is shown as follows:

Command code: 03<sub>H</sub>, read N words(word), N ≦ 20.

For example: read 2 words starting from 0200<sub>H</sub> from the servodrive which address is 01<sub>H</sub>.

**ASCII mode:**

Reference information:

STX	“: ”
ADR	'0'
	'1'
CMD	'0'
	'3'
Data start address	'0'
	'2'
	'0'
	'0'
Data number (count as word)	'0'
	'0'
	'0'
	'2'
LRC checking	'F'
	'8'
End 1	(0D <sub>H</sub> )(CR)
End 0	(0A <sub>H</sub> )(LF)

Response information:

STX	“: ”
ADR	'0'
	'1'
CMD	'0'
	'3'
Data number (count as byte)	'0'
	'4'
Content of data start address 0200 <sub>H</sub>	'0'
	'0'
	'B'
Content of second data address 0201 <sub>H</sub>	'1'
	'F'
	'4'
LRC checking	'0'
	'E'
End 1	'8'
	(0D <sub>H</sub> )(CR)
End 0	(0A <sub>H</sub> )(LF)

**RTU mode:**

Reference information: :

ADR	01 <sub>H</sub>
CMD	03 <sub>H</sub>
Data start address	02 <sub>H</sub> (high-bit)
	00 <sub>H</sub> (low-bit)
Data number (count as word)	00 <sub>H</sub>
	02 <sub>H</sub>
CRC checking	C5 <sub>H</sub> (low-bit)
CRC checking	B3 <sub>H</sub> (high-bit)

Response information:

ADR	01 <sub>H</sub>
CMD	03 <sub>H</sub>
Data number (count as byte)	04 <sub>H</sub>
Content of data start address 0200 <sub>H</sub>	00 <sub>H</sub> (high-bit)
	B1 <sub>H</sub> (low-bit)
Content of second data address 0201 <sub>H</sub>	1F <sub>H</sub> (high-bit)
	40 <sub>H</sub> (low-bit)
CRC checking	A3 <sub>H</sub> (low-bit)
CRC checking	D3 <sub>H</sub> (high-bit)



Reference code: 06<sub>H</sub>, write in one word

For example: write 100 (0064<sub>H</sub>) into 01<sub>H</sub> servo address 0200<sub>H</sub>.

**ASCII mode:**

Reference information:

STX	“:”
ADR	‘0’
	‘1’
CMD	‘0’
	‘6’
Data start address	‘0’
	‘2’
	‘0’
	‘0’
Data content	‘0’
	‘0’
	‘6’
	‘4’
LRC checking	‘9’
	‘3’
End 1	(0D <sub>H</sub> )(CR)
End 0	(0A <sub>H</sub> )(LF)

Response information:

STX	“:”
ADR	‘0’
	‘1’
CMD	‘0’
	‘6’
Data start address	‘0’
	‘2’
	‘0’
	‘0’
Content of data start address 0200 <sub>H</sub>	‘0’
	‘0’
	‘6’
	‘4’
LRC checking	‘9’
	‘3’
End 1	(0D <sub>H</sub> )(CR)
End 0	(0A <sub>H</sub> )(LF)

**RTU mode:**

Reference information:

ADR	01 <sub>H</sub>
CMD	06 <sub>H</sub>
Data start address	02 <sub>H</sub> (high-bit)
	00 <sub>H</sub> (low-bit)
Data content	00 <sub>H</sub> (high-bit)
	64 <sub>H</sub> (low-bit)
CRC checking	89 <sub>H</sub> (low-bit)
CRC checking	99 <sub>H</sub> (high-bit)

Response information:

ADR	01 <sub>H</sub>
CMD	06 <sub>H</sub>
Data start address	02 <sub>H</sub> (high-bit)
	00 <sub>H</sub> (low-bit)
Data content	00 <sub>H</sub> (high-bit)
	64 <sub>H</sub> (low-bit)
CRC checking	89 <sub>H</sub> (low-bit)
CRC checking	99 <sub>H</sub> (high-bit)

LRC (ASCII mode) and CRC (RTU mode) error detection value calculation:

**LRC calculation in ASCII mode:**

ASCII mode uses LRC (Longitudinal Redundancy Check) error detection value. The exceeded parts (e.g. the total value is 128<sub>H</sub> of hex, then take 28<sub>H</sub> only) is taken off by the unit of 256 in the total value from ADR to the last information, then calculate and compensate, the final result is LRC error detection value.

For example: read 1 word from 01<sub>H</sub> servo address 0201<sub>H</sub>

STX	‘:’
ADR	‘0’
	‘1’
CMD	‘0’
	‘3’
Data start address	‘0’
	‘2’
	‘0’
	‘1’
Data number (count as word)	‘0’
	‘0’
	‘0’
	‘1’
LRC checking	‘F’
	‘8’
End 1	(0D <sub>H</sub> )(CR)
End 0	(0A <sub>H</sub> )(LF)

**Add from ADR data to the last data.**

$$01_{\text{H}} + 03_{\text{H}} + 02_{\text{H}} + 01_{\text{H}} + 00_{\text{H}} + 01_{\text{H}} = 08_{\text{H}}$$

The compensate value is F8<sub>H</sub> when 2 is used to compensate 08<sub>H</sub>, so LRC is “F”, “8”.

**CRC calculation of RTU mode:**

RTU mode uses CRC (Cyclical Redundancy Check) error detection value.

The process of CRC error detection value calculation is shown as follows:

Step 1: Load in a 16-bit register of FFFF<sub>H</sub>, named “CRC” register.

Step 2: Run XOR calculation between the first bit (bit 0) of instruction information and 16-bit CRC register’s low bit (LSB), and the result is saved to CRC register.

Step 3: Check the lowest bit (LSB) of CRC register, if it is 0, CRC register moves one bit to right; if it is 1, CRC register moves one bit to right, then run XOR calculation with A001<sub>H</sub>;

Step 4: Go to step 5 till the third step has been executed for 8 times, otherwise return to step 3.

Step 5: Repeat the steps from 2 to 4 for the next bit of instruction information, the comment of CRC register is the CRC error detection value while all the bits have been executed by the same way.

Note: After calculating out the CRC error detection value, the CRC low bit should be filled first in instruction information, and then fill the high bit of CRC.

Please refer to the following example:

Read 2 words from the 0101<sub>H</sub> address of 01<sub>H</sub> servo. The final CRC register content calculated from ADR to the last bit of data is 3794<sub>H</sub>, and then the instruction information is shown as follows,

Please be sure that 94<sub>H</sub> is transmitted before 37<sub>H</sub>.

ADR	01 <sub>H</sub>
CMD	03 <sub>H</sub>
Data start address	01 <sub>H</sub> (high-bit)
	01 <sub>H</sub> (low-bit)
Data number (count as word)	00 <sub>H</sub> (high-bit)
	02 <sub>H</sub> (low-bit)
CRC checking	94 <sub>H</sub> (low-bit)
CRC checking	37 <sub>H</sub> (high-bit)

**End1、End0 (Communication is complete.)**

**ASCII mode:**

Communication is end with (0D<sub>H</sub>) namely character '\r' [carriage return] and (0A<sub>H</sub>) namely character '\n' [new line] .

**RTU mode:**

When the time exceeds the sleep interval of at least 4 bytes transmission time in current communication speed means the communication is finished.

**Example:**

The following example uses C language to generate CRC value. The function needs two parameters.

```
unsigned char * data;
```

```
unsigned char length;
```

The function will return unsigned integer type CRC value.

```
unsigned int crc_chk(unsigned char * data,unsigned char length){
    int i,j;
    unsigned int crc_reg=0xFFFF;
    While(length- -){
        crc_reg ^=*data++;
        for(j=0;j<8;j++){
            If(crc_reg & 0x01){
                crc_reg=( crc_reg >>1)^0xA001;
            }else{
                crc_reg=crc_reg >>1;
            }
        }
    }
    return crc_reg;
}
```

## 6.3.2 Communication Error Disposal

Problems that occur during communication are resulted by the following reasons:

- Data address is incorrect while reading/writing parameters.
- The data is not within the parameter setting range while writing.
- Data transmission fault or checking code fault when communication is disturbed.

When the first and second communication faults occur, the servodrive is running normally, and will feed back an error frame.

When the third communication fault occurs, transmission data will be recognized as invalid to give up, and no error frame is returned.

The format of error frame:

### Host controller data frame:

start	Slave station address	Command	Data address,content	Checking
		command		

### Servodrive feeds back error frame:

start	Slave station address	Response code	Error code	Checking
		command+80 <sub>H</sub>		

Error frame responses code=command+80<sub>H</sub>

Error code=00<sub>H</sub>: Normal communication

=01<sub>H</sub>: Servodrive cannot identify the required functions

=02<sub>H</sub>: The required data address does not exist in the servodrive

=03<sub>H</sub>: The required data in servodrive is not allowed. (Beyond the maximum or minimum value of the parameter)

=04<sub>H</sub>: Servodrive starts to perform the requirement, but cannot achieve it.

**For example:** Servodrive axis number is 03<sub>H</sub>, write data 06<sub>H</sub> into parameter Pn100 is not allowed, because the range of parameter Pn100 is 0~6. The servodrive will feedback an error frame, the error code is 03<sub>H</sub> (Beyond the parameter's maximum value or minimum value).

### Host controller data frame:

start	Slave station address	Command	Data address,content	Checking
	03 <sub>H</sub>	06 <sub>H</sub>	0002 <sub>H</sub> 0006 <sub>H</sub>	

### Servodrive feedback error frame:

start	Slave station address	Response code	Error code	Checking
	03 <sub>H</sub>	86 <sub>H</sub>	03 <sub>H</sub>	

Besides, if the data frame sent from host controller slave station address is 00<sub>H</sub>, it represents this data is broadcast data, servodrives will not feed back any frames.

### 6.3.3 Data Communication Address of Servo State

The communication parameters addresses are shown in the following table:

Communication data address	Meaning	Description	Operation
Hex			
0000 ~ 02FD	Parameter area	Corresponding parameters in parameter list	Read/write
07F1 ~07FA	Alarm information memory area	Ten alarms historical record	Read only
07FB	Speed reference zero offset		Read only
07FC	Torque reference zero offset		Read only
07FD	Iu zero offset		Read only
07FE	Iv zero offset		Read only
0806 ~ 0814	Monitor data (corresponding with displayed data)		
0806	Speed feedback	Unit:rpm	Read only
0807	Input speed reference value	Unit:rpm	Read only
0808	Input torque reference percentage	Relative rated torque	Read only
0809	Internal torque reference percentage	Relative rated torque	Read only
080A	Number of encoder rotation pulses		Read only
080B	Input signal state		Read only
080C	Encoder signal state		Read only
080D	Output signal state		Read only
080E	Pulse settign		Read only
080F	Low bits of present location	Unit:1 reference pulse	Read only
0810	High bits of present location	Unit:10000 reference pulses	Read only
0811	Error pulse counter low 16 bits		Read only
0812	Error pulse counter high 16 bits		Read only
0813	Setting pulse counter low bits	Unit:1 reference pulse	Read only
0814	Setting pulse counter high bits	Unit:10000 reference pulses	Read only
0815	Load inertia percentage	%	Read only
0816	Servomotor overloading proportion	%	Read only
0817	Current alarm		Read only
0900	MODBUS communication IO signal	Donot save when power off.	Read/write
090E	DSP version	Version is expressed by digit.	Read only
090F	CPLD version	Version is expressed by digit.	Read only

Communication data address	Meaning	Description	Operation
Hex			
1021	Clear historical alarms	01:Clear	Write only
1022	Clear current alarms	01:Clear	Write only
1023	JOG servo enabled	01:Enable 00:Disable	Read/write
1024	JOG forward rotation	01:Forward rotation 00:Stop	Read/write
1025	JOG reverse rotation	01:Reverse rotation 00:Stop	Read/write
1026	JOG forward rotation at node position( start signal has been set)	01:Forward rotation 00:Stop	
1027	JOG reverse rotation at node position(start signal has been set)	01:Reverse rotation 00:Stop	
1028	Pause at node position	01:Pause 00:Cancel pause	

Note:

1. Parameter area (communication address 0000~00DE<sub>H</sub>)

Parameter address is relevant to the parameters in the parameter list.

For example, parameter Pn000 is relevant to communication address 0000<sub>H</sub>; parameter Pn101 is relevant to communication address 0065<sub>H</sub>. Read/write operation to address 0000<sub>H</sub> is the read/write operation to Pn000. If the communication input data is not within the parameter range, the data will be aborted and servodrive will return an operation unsuccessful signal.

2. Alarm information storage area (07F1~07FA<sub>H</sub>)

Historical alarm number	Description	Communication address
0	Historical alarm 1 (the latest alarm)	07F1 <sub>H</sub>
1 ~ 8	Historical alarm 1 ~ 9	07F2 <sub>H</sub> ~ 07F9 <sub>H</sub>
9	Historical alarm 10 (the furthest alarm)	07FA <sub>H</sub>

3. Monitor data area (0806~0816<sub>H</sub>)

The monitor data is corresponding to servodrive panel displays Un000~Un016.

For example: the corresponding data of communication address 0807<sub>H</sub> (speed setting) is FB16<sub>H</sub>.

Therefore, the speed setting is -1258r/m.

4. MODBUS communication IO signal

Use communication to control digital IO signal. This data will not be saved after power off.

It is operated with Pn512 and Pn513 as the communication input IO signal. That is to say, when the parameters setting in Pn512 and Pn513 enable the IO bit, the IO can be controlled by communication.

5. Software version (090F<sub>H</sub>)

Use digit to represent servodrive software version. For example, if the read out data is D201<sub>H</sub>, it means the software version is D-2.01.

# Chapter 7

## Specifications and Characters

### 7.1 Servodrive Specifications and Models

Servodrive Model:		ProNet-E-	02A	04A	08A	10A	15A	20A	30A	50A	10D	15D
Applicable Servomotor Model:	EMJ	02A	04A	08A	10A	—	—	—	—	—	—	—
	EMG-	—	—	—	10A	15A	20A	30A	50A	10D	15D	—
	EML-	—	—	—	10A	—	20A	30A	40A	10D	—	—
Continuous Output Current [Arms]		1.4	2.8	4.0	6.0	9.0	12.0	18.0	28.0	3.0	4.8	—
Max. Output Current [Arms]		4.2	8.4	12.0	18.0	28.0	42.0	56.0	84.0	9.0	14.4	—
Input Power Supply	Main Circuit	Three-phase 200~230VAC +10%~-15% (50/60Hz)						Three-phase 380~440VAC +10%~-15%(50/60Hz)				
	Control Circuit	Single-phase 200~230VAC +10%~-15% (50/60Hz)						Single-phase 380~440VAC +10%~-15%(50/60Hz)				
	Power Supply Capacity [kVA]	0.5	0.9	1.3	1.8	2.5	3.5	4.5	7.5	1.8	2.5	—
Control Method		SVPWM Control										
Feedback		Wire-saving Incremental Encoder: 2500P/R										
Operating Conditions	Ambient/Storage Temperature	Ambient temperature: 0~+55℃ Storage temperature: -20~+85℃										
	Ambient/Storage Humidity	90% RH or less (with no condensation)										
	Elevation	1000m or less										
	Vibration/Shock Resistance	Vibration Resistance: 4.9m/s <sup>2</sup> , Impact Resistance: 19.6m/s <sup>2</sup>										
Configuration		Base-mounted										
Performance	Speed Control Range		1:5000									
	Speed Regulation	Load Regulation	0~100% load: ±0.01% or less (at rated speed)									
		Voltage Regulation	Rated voltage ±10%: 0% (at rated speed)									
		Temperature Regulation	25±25℃: ±0.1% or less (at rated speed)									
Torque Control	Analog Reference Input	Reference Voltage	±10VDC at rated torque (Variable setting range:±0~10VDC) Max. input voltage: ±12V									
		Input Impedance	About 10MΩ or above									
		Circuit Time Constant	10μs									
Speed Control	Analog Input Reference	Reference Voltage	±10VDC at rated speed (Variable setting range:±0~10VDC) Max. input voltage: ±12V									

Servodrive Model:		ProNet-E-	02A	04A	08A	10A	15A	20A	30A	50A	10D	15D
Applicable Servomotor Model:	EMJ	02A	04A	08A	10A	—	—	—	—	—	—	—
	EMG-	—	—	—	10A	15A	20A	30A	50A	10D	15D	—
	EML-	—	—	—	10A	—	20A	30A	40A	10D	—	—
	Input	Input	About 10MΩ or above									
		Circuit Time Constant	10μs									
	Speed Selection	Rotation Direction Selection	With /P-CON signal									
		Speed	Speed 1 to 7									
	Function	Soft Start Setting	0~10s ( Can be set individually for acceleration and deceleration. )									
Position Control	Pulse Reference	Type	Sign + pulse train;CCW + CW pulse train; 90°phase difference 2-phase (phase A + phase B)									
		Form	Non-insulated linde driver (about + 5V), open collector									
		Frequency	×1 multiplier: 4Mpps ×2 multiplier: 2Mpps ×4 multiplier: 1Mpps Open collector: 200Kpps Frequency will begin to decline when the duty ratio error occurs..									
	Position Reference Setting	Position Setting	16 postion nodes can be set.									
I/O Signals	Encoder Dividing Pulses Output		Phase-A, phase-B, phase-C, line driver output Number of dividing pulses: any									
	Sequence Input	Number of channels	8 channels									
		Function	Signal allocations and positive/negative logic modifications: Servo ON (/S-ON), P control (/P-CON), alarm reset (/ALM-RST), position error clear (/CLR), forward run prohibited (P-OT), reverse run prohibited (N-OT), forward current limit (/P-CL), reverse current limit (/N-CL)									
	Sequence Output	Number of channels	4 channels									
		Function	Signal allocations and positive/negative logic modifications: Positioning completion(/COIN), speed coincidence(/V-CMP),servomotor rotation detection(/TGON), servo ready(/S-RDY),torque limit output(/CLT), brake interlock output (/BK), encoder C pulse(/PGC)									
	Internal Functions	Dynamic Brake		Operated at main power OFF, servo alarm, servo OFF or overtravel.								
Regenerative Functions		750W~5.0kW: internal regenerative resistor; 200W~400W: external regenerative resistor										
Protection Functions		Overcurrent, overvoltage,low voltage, overload,regeneration error,overtravel.										
Utility Function		Alarm trace back、JOG operation、 inertia detection, etc..										
Display Function		CHARGE (Red)、POWER (Green)、 five 7-segment LEDS (Built-in panel operator)										
Communication Functiion		RS-485 communication port, MODBUS protocol; CAN communication port, CANOpen protocol.										



## 7.2 Servodrive Dimensional Drawings

### ■ ProNet-E-02A/04A

Unit: mm

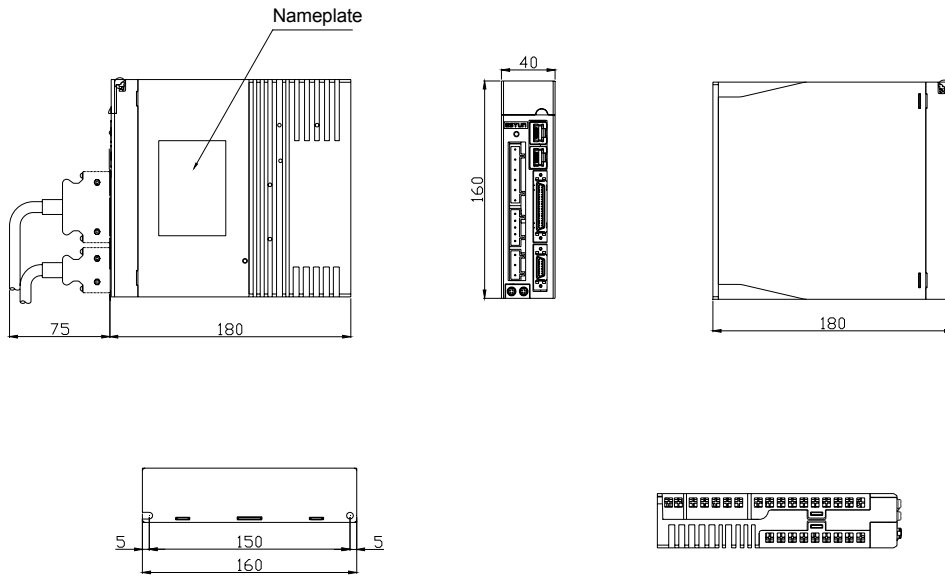

### ■ ProNet-E-08A/10A

Unit: mm

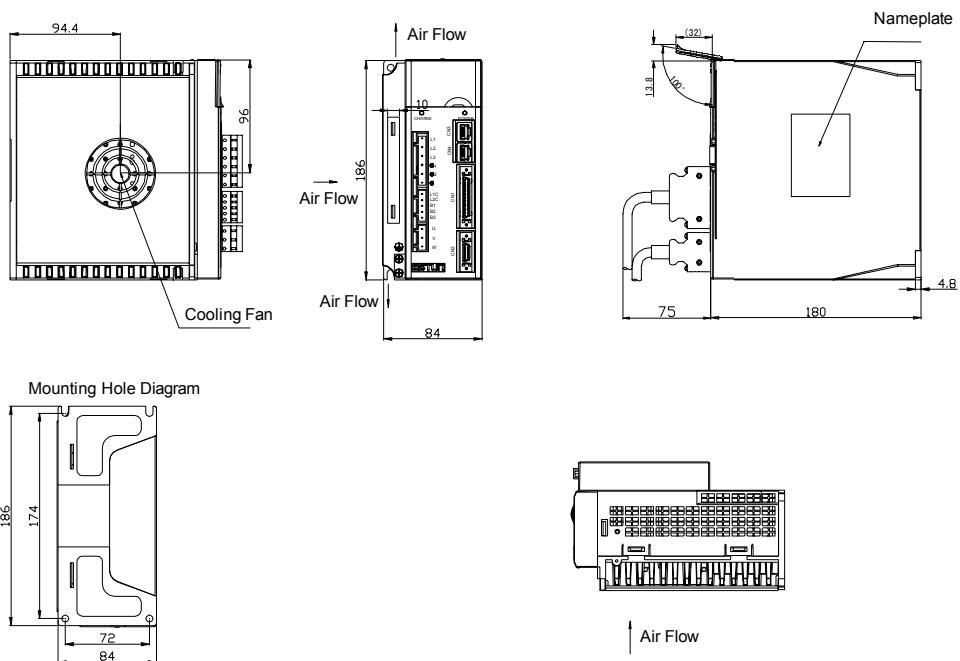

## ■ ProNet-E-10D/15A/15D

Unit:mm

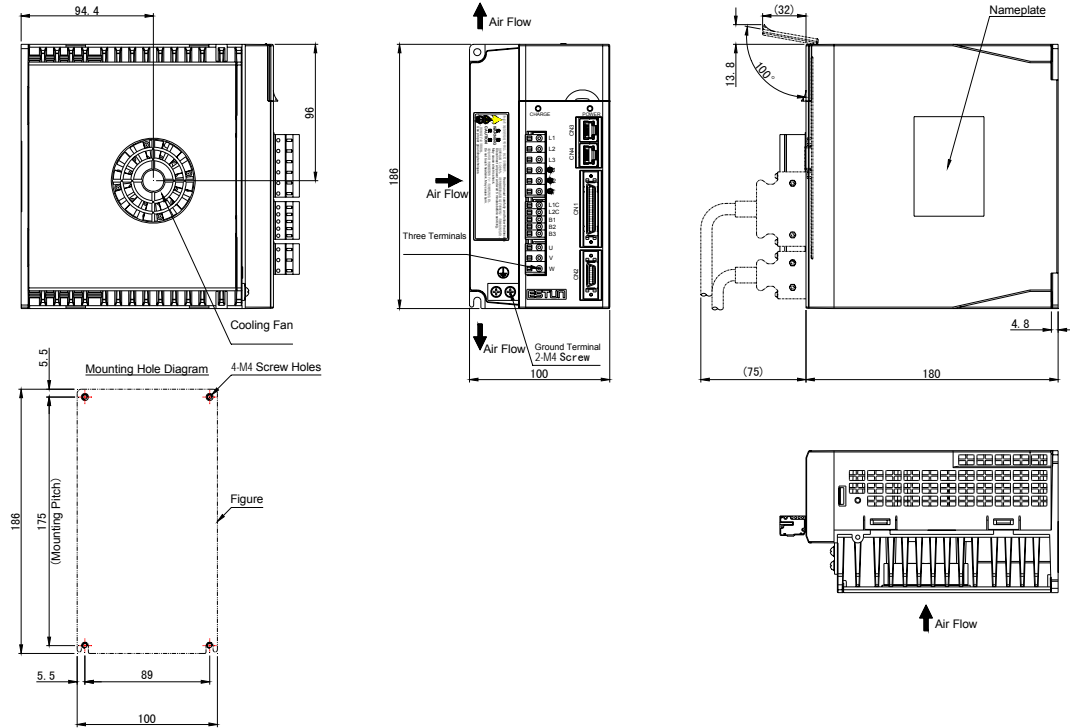

## ■ ProNet-E-20A/30A/50A

Unit:mm

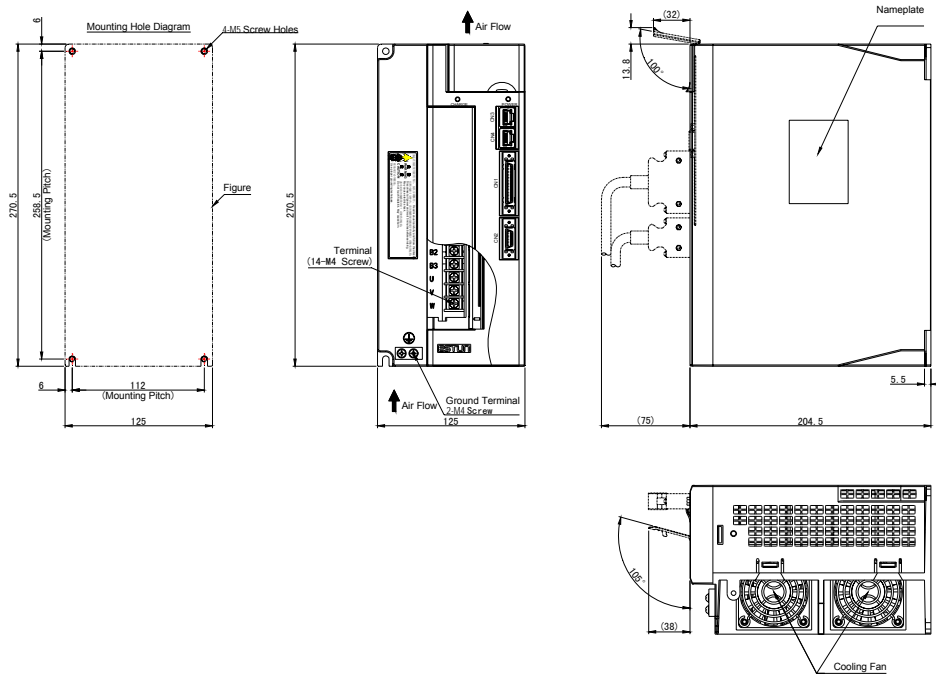

# Appendix A

## Parameter

### A.1 Parameter List

Parameter No.	Name	Unit	Setting Range	Factory Setting	Setting Invalidation
Pn000	<b>Binary</b> Pn000.0: Servo ON Pn000.1: Forward rotation input signal prohibited (P-OT) Pn000.2: Reverse rotation input signal prohibited (N-OT) Pn000.3: Alarm output when instantaneous power loss	—	0~1111	0	After restart
Pn001	<b>Binary</b> Pn001.0: CCW,CW selection Pn001.1: Analog speed limit enabled Pn001.2: Analog torque limit enabled Pn001.3: 2nd electronic gear enabled	—	0~1111	0	After restart
Pn002	<b>Binary</b> Pn002.0: Electronic gear switching mode Pn002.1: Reserved Pn002.2: Reserved Pn002.3: Reserved	—	0~0111	0010	After restart
Pn003	<b>Binary</b> Pn003.0: Reserved Pn003.1: Reserved Pn003.2: Low speed compensation Pn003.3: Overload enhancement	—	0~1111	0	After restart
Pn004	<b>Hex</b> Pn004.0: Stop mode Pn004.1: Error counter clear mode Pn004.2: Reference pulse form Pn004.3: Inverses pulse	—	0~0x3425	0	After restart

Parameter No.	Name	Unit	Setting Range	Factory Setting	Setting Invalidation
Pn005	<p><b>Hex</b></p> <p>Pn005.0: Torque feedforward mode</p> <p>Pn005.1: Control mode</p> <p>[0] Speed control(analog reference)</p> <p>[1] Position control(pulse train)</p> <p>[2] Torque control(analog reference)</p> <p>[3]Speedcontrol(contact reference)←→ speed control(zero reference)</p> <p>[4] Speed control(contact reference)←→ speed control(analog reference)</p> <p>[5] Speed control(contact reference)←→ position control(pulse train)</p> <p>[6] Speed control(contact reference)←→ torque control(analog reference)</p> <p>[7] Position control(pulse train)←→ speed control(analog reference)</p> <p>[8] Position control(pulse train)←→ torque control(analog reference)</p> <p>[9] Torque control(analog reference)←→ speed control(analog reference)</p> <p>[A] Speed control(analog reference)←→ zero clamp</p> <p>[B] Position control(pulse train)←→ position control(inhibit)</p> <p>[C] Position control (contact reference)</p> <p>[D] Speed control(parameter reference)</p> <p>[E] Pressure control(analog reference)</p> <p>Pn005.2:Out-of-tolerance alarm selection</p> <p>Pn005.3:Servomotor model</p>	—	0~0x33E3	0	After restart
Pn006	<p><b>Hex</b></p> <p>Pn006.0: Bus mode</p> <p>Pn006.1: Reserved</p> <p>Pn006.2: Low frequency jitter suppression switch</p> <p>Pn006.3: Reference input filter for open collector signal</p>	—	0~0x2133	0x0020	After restart
Pn007	<p><b>Binary</b></p> <p>Pn007.0: wider the width of C pulse or not</p> <p>Pn007.1: Reserved</p> <p>Pn007.2: Reserved</p> <p>Pn007.3: Reserved</p>	—	0~0001	0	After restart
Pn100	<p><b>Online autotuning setting</b></p> <p>0:Manual gain adjustment</p> <p>1,2,3=Normal mode;4,5,6=Vertical load</p>	—	0~6	1	After restart

Parameter No.	Name	Unit	Setting Range	Factory Setting	Setting Invalidation
	1,4 = Load inertia without variation; 2,5 = Load inertia with little variation; 3,6=Load inertia with great variation				
Pn101	Machine rigidity setting	—	0~15	5	Immediately
Pn102	Speed loop gain	Hz	1~2500	160	Immediately
Pn103	Speed loop integral time constant	0.1ms	1~4096	200	Immediately
Pn104	Position loop gain	1/s	0~1000	40	Immediately
Pn105	Torque reference filter time constant	0.1ms	0~250	4	Immediately
Pn106	Load inertia percentage	—	0~20000	0	Immediately
Pn107	2nd speed loop gain	Hz	1~2500	40	Immediately
Pn108	2nd speed loop integral time constant	0.1ms	1~4096	200	Immediately
Pn109	2nd position loop gain	Hz	0~1000	40	Immediately
Pn110	2nd torque reference filter time constant	0.1ms	0~250	4	Immediately
Pn111	Speed bias	rpm	0~300	0	Immediately
Pn112	Feedforward	%	0~100	0	Immediately
Pn113	Feedforward filter	0.1ms	0~640	0	Immediately
Pn114	Torque feedforward	%	0~100	0	Immediately
Pn115	Torque feedforward filter	0.1ms	0~640	0	Immediately
Pn116	<b>P/PI switching condition</b> 0:Torque reference percentage 1:Value of offset counter 2:Value of acceleration speed setting 3:Value of speed setting 4:Fixed PI	—	0~4	0	After restart
Pn117	Torque switching threshold	%	0~300	200	Immediately
Pn118	Offset counter switching threshold	reference pulse	0~10000	0	Immediately
Pn119	Setting acceleration speed switching threshold	10rpm/s	0~3000	0	Immediately
Pn120	Setting speed switching threshold	rpm	0~10000	0	Immediately
Pn121	<b>Gain switching condition</b> 0:Fix to 1st group gain 1:External switch gain switching 2:Torque percentage 3:Value of offset counter 4:Value of acceleration speed setting 5:Value of speed setting 6:Speed reference input	—	0~6	0	After start
Pn122	Switching delay time	0.1ms	0~20000	0	Immediately
Pn123	Threshold switching level		0~20000	0	Immediately
Pn124	Reserved	—	—	—	—
Pn125	Position gain switching time	0.1ms	0~20000	0	Immediately
Pn126	Hysteresis switching		0~20000	0	Immediately

Parameter No.	Name	Unit	Setting Range	Factory Setting	Setting Invalidation
Pn127	Low speed detection filter	0.1ms	0~100	10	Immediately
Pn128	Speed gain acceleration relationship during online autotuning	—	0~3	3	Immediately
Pn129	Low speed correction coefficient	—	0~30000	0	Immediately
Pn130	Friction load	0.1%	0~3000	0	Immediately
Pn131	Friction compensation speed hysteresis area	rpm	0~100	0	Immediately
Pn132	Sticking friction load	0.1%/1000rpm	0~1000	0	Immediately
Pn133	Reserved	—	—	—	—
Pn134	Reserved	—	—	—	—
Pn135	Reserved	—	—	—	—
Pn136	Reserved	—	—	—	—
Pn137	Reserved	—	—	—	—
Pn138	Reserved	—	—	—	—
Pn139	Reserved	—	—	—	—
Pn140	Reserved	—	—	—	—
Pn141	Reserved	—	—	—	—
Pn142	Reserved	—	—	—	—
Pn143	Reserved	—	—	—	—
Pn144	Reserved	—	—	—	—
Pn200	PG divided ratio	Puls	16~16384 (Pn840.0=3/4/5) 1~2500 (Pn840.0=6)	16384 (Pn840.0=3/4/5) 2500 (Pn840.0=6)	After restart
Pn201	1st electronic gear numerator	—	1~65535	1	After restart
Pn202	Electronic gear denominator	—	1~65535	1	After restart
Pn203	2nd electronic gear numerator	—	1~65535	1	After restart
Pn204	Position reference Acceleration /deceleration time constant	0.1ms	0~32767	0	Immediately
Pn205	Position reference filter form selection	—	0~1	0	After restart
Pn300	Speed reference input gain	rpm/v	0~3000	150	Immediately
Pn301	Analog speed given zero bias	10mv	-1000~1000	0	Immediately
Pn302	Reserved	—	—	—	—
Pn303	Reserved	—	—	—	—
Pn304	Parameter speed	rpm	0~6000	500	Immediately
Pn305	JOG speed	rpm	0~6000	500	Immediately
Pn306	Soft start acceleration time	ms	0~10000	0	Immediately
Pn307	Soft start deceleration time	ms	0~10000	0	Immediately
Pn308	Speed filter time constant	ms	0~10000	0	Immediately
Pn309	S curve risetime	ms	0~10000	0	Immediately
Pn310	<b>Speed reference curve form</b> 0:Slope 1:S curve	—	0~3	0	After restart

Parameter No.	Name	Unit	Setting Range	Factory Setting	Setting Invalidation
	2:1 <sup>st</sup> order filter 3:2 <sup>nd</sup> order filter				
Pn311	S form selection	—	0~3	0	Immediately
Pn312	DP communication JOG speed	rpm	-6000~6000	500	Immediately
Pn313	Reserved	—	—	—	—
Pn314	Reserved	—	—	—	—
Pn315	Reserved	—	—	—	—
Pn316	Internal speed 1	rpm	-6000~6000	100	Immediately
Pn317	Internal speed 2	rpm	-6000~6000	200	Immediately
Pn318	Internal speed 3	rpm	-6000~6000	300	Immediately
Pn319	Internal speed 4	rpm	-6000~6000	-100	Immediately
Pn320	Internal speed 5	rpm	-6000~6000	-200	Immediately
Pn321	Internal speed 6	rpm	-6000~6000	-300	Immediately
Pn322	Internal speed 7	rpm	-6000~6000	500	Immediately
Pn400	Torque reference gain	0.1V/100%	10~100	33	Immediately
Pn401	Forward torque internal limit①	%	0~300	300	Immediately
Pn402	Reverse torque internal limit①	%	0~300	300	Immediately
Pn403	Forward external torque limit①	%	0~300	100	Immediately
Pn404	Reverse external torque limit①	%	0~300	100	Immediately
Pn405	Plug braking torque limit①	%	0~300	300	Immediately
Pn406	Speed limit during torque control	rpm	0~6000	1500	Immediately
Pn407	Notch filter 1 frequency	Hz	50~5000	5000	Immediately
Pn408	Notch filter 1 depth	—	0~11	1	Immediately
Pn409	Notch filter 2 frequency	Hz	50~5000	5000	Immediately
Pn410	Notch filter 2 depth	—	0~11	1	Immediately
Pn411	Low frequency jitter frequency	0.1Hz	50~500	100	Immediately
Pn412	Low frequency jitter damp	—	0~200	25	Immediately
Pn413	Torque control delay time	0.1ms	1~2000	100	Immediately
Pn414	Torque control speed hysteresis	rpm	10~1000	50	Immediately
Pn415	Analog torque given zero bias	10mv	-1000~1000	0	Immediately
Pn500	Positioning error	Puls	0~5000	10	Immediately
Pn501	Coincidence difference	rpm	0~100	10	Immediately
Pn502	Zero clamp speed	rpm	0~3000	10	Immediately
Pn503	Rotation detection speed TGON	rpm	0~3000	20	Immediately
Pn504	Offset counter overflow alarm	256Puls	1~32767	1024	Immediately
Pn505	Servo ON waiting time	ms	-2000~2000	0	Immediately
Pn506	Basic waiting flow	10ms	0~500	0	Immediately
Pn507	Brake waiting speed	rpm	10~100	100	Immediately
Pn508	Brake waiting time	10ms	10~100	50	Immediately
Pn509	Allocate input signal to terminal	—	0~0xEEEE	0x3210	After restart
Pn510	Allocate input signal to terminal	—	0~0xEEEE	0x7654	After restart
Pn511	Allocate output signal to terminal	—	0~0x0888	0x0210	After restart
Pn512	Bus control input node low-bit enable		0~1111	0	Immediately

Parameter No.	Name	Unit	Setting Range	Factory Setting	Setting Invalidation
Pn513	Bus control input node low-bit enable		0~1111	0	Immediately
Pn514	Input port filter	0.2ms	0~1000	1	Immediately
Pn515	Reserved	—	—	—	—
Pn516	Input port signal inversion	—	0~1111	0	Immediately
Pn517	Input port signal inversion	—	0~1111	0	Immediately
Pn518	Reserved	—	—	—	—
Pn519	Reserved	—	—	—	—
Pn520	Reserved	—	—	—	—
Pn521	If connect externally regenerative resistor 0: connect externally regenerative resistor between B1 and B2 1: dose not connect externally regenerative resistor, relay on interna capacitance ( This parameter is in effect only on ProNet-E-02/04 )	—	0~1	1	Immediately
Pn522	Reserved	—	—	—	—
Pn523	Reserved	—	—	—	—
Pn524	Reserved	—	—	—	—
Pn525	Overload alarm threshold	%	100~150	100	Immediately
Pn600	Position pulse in point to point control	10000P	-9999~9999	0	Immediately
Pn601	Position pulse in point to point control	1P	-9999~9999	0	Immediately
	.....				
Pn630	Position pulse in point to point control	1P	-9999~9999	0	Immediately
Pn631	Position pulse in point to point control	1P	-9999~9999	0	Immediately
Pn632	Point to point speed control	rpm	0~3000	500	Immediately
	.....				
Pn647	Point to point speed control	rpm	0~3000	500	Immediately
Pn648	Point to point 1st order filter	0.1ms	0~32767	0	Immediately
	.....				
Pn663	Point to point 1st order filter	0.1ms	0~32767	0	Immediately
Pn664	Stop time	50ms	0~300	10	Immediately
	.....				
Pn679	Stop time	50ms	0~300	10	Immediately
Pn680	Reserved	—	—	—	—
Pn681	<b>Hex</b> Pn681.0:Single/cyclic, start/reference point selection Pn681.1:Change step and start mode Pn681.2:Change step input signal mode Pn681.3:Reserved	—	0~x0333	0x0000	Immediately
Pn682	Programme mode	—	0~1	0	Immediately
Pn683	Programme start step	—	0~15	0	Immediately



Parameter No.	Name	Unit	Setting Range	Factory Setting	Setting Invalidation
Pn684	Programme stop step	—	0~15	1	Immediately
Pn685	Search travel speed in position control(contact reference); Speed of finding reference point(Hitting the origin signal ORG) in position homing control.	rpm	0~3000	1500	Immediately
Pn686	Leave travel switch speed in position control(contact reference); Speed of finding reference point(Leaving the origin signal ORG) in position homing control.	rpm	0~200	30	Immediately
Pn687	Position teaching pulse	10000P	-9999~9999	0	Immediately
Pn688	Position teaching pulse	1P	-9999~9999	0	Immediately
Pn689	Homing Mode Setting	—	0~0111	0	After restart
Pn690	Number of error pulses during homing	10000pulse	0~9999	0	Immediately
Pn691	Number of error pulses during homing	1pulse	0~9999	0	Immediately
Pn700	<b>Hex</b> Pn700.0: MODBUS communication baud rate Pn700.1: MODBUS protocol selection Pn700.2:Communication protocol selection Pn700.3: Reserved	—	0~0x0182	0x0151	After restart
Pn701	MODBUS axis address	—	1~247	1	After restart
Pn702	Reserved	—	—	—	—
Pn703	CAN communication speed	—	0x0005	0x0004	After restart
Pn704	CAN communication contact	—	1~127	1	After restart
Pn840	<b>Hex</b> Pn840.0: Encoder model selection Pn840.1: Reserved Pn840.2: Reserved Pn840.3: Reserved	—	0x0006~ 0x0706	—	After restart

Note: ① The setting range and factory setting of Pn401 to Pn405 are depending on the actual overload capacity.

## A.2 Description of Parameter Type

Type	Parameter No.	Description
Function selection switches	Pn000~Pn006	Control mode, stop mode, and some functions selection
Parameters of servo gain	Pn100~Pn129	Position gain, speed gain, rigidity, etc.
Position control related parameters	Pn200~Pn205	PG divided ratio, electronic gear, etc.
Speed control related parameters	Pn300~Pn322	Speed reference input, soft start, etc.
Torque control related parameters	Pn400~Pn406	Torque limit, etc.
Parameters to control I/O port	Pn500~Pn520	Allocation of I/O port function
Point-to-point control related parameters	Pn600~Pn686	Internal point-to-point control related parameters
Communication parameters	Pn700~Pn701	Setting of communication parameters

## A.3 Parameters in detail

Parameter No.	Description	Setting Validation	Control Mode	Function and Meaning
Pn000	Binary	After restart	ALL	<p><b>Pn000.0 Servo ON</b>            [0] External S-ON enabled            [1] External S-ON disabled. servomotor excitation signal is turned ON automatically after S-RDY is output.</p> <p><b>Pn000.1 Forward rotation input signal prohibited (P-OT)</b>            [0] External P-OT enabled. Operate in the time sequence setting in Pn004.0 when travel limit occurs.            [1] External P-OT disabled.</p> <p><b>Pn000.2 Reverse rotation input signal prohibited (N-OT)</b>            [0] External N-OT enabled. Operate in the time sequence setting in Pn004.0 when travel limit occurs.            [1] External N-OT disabled.</p> <p><b>Pn000.3 Alarm output when instantaneous power loss</b>            [0] Instantaneous power loss for one period with no alarm output            [1] Instantaneous power loss for one period without alarm output</p>
Pn001	Binary	After restart	Pn001.0 ALL Pn001.1 T Pn001.2 P, S Pn001.3 P	<p><b>Pn001.0 CCW,CW selection</b>            [0] Sets CCW as forward direction            [1] Sets CW as forward direction</p> <p><b>Pn001.1 Analog speed limit enabled</b>            [0] Sets the value of Pn406 as the speed limit value during torque control. (Internal speed limit )            [1] Use the lower speed between V-REF and Pn406 as an external speed limit input. (external speed limit )</p> <p><b>Pn001.2 Analog torque limit enabled</b>            [0] Sets Pn401~Pn404 as torque limit.            [1] Sets the value corresponding to Vref input analog voltage as torque limit.</p> <p><b>Pn001.3 2nd electronic gear enabled</b>            [0] Without 2nd electronic gear, PCON signal is used to switch P/PI            [1] 2nd electronic gear is enabled, PCON signal is only used as 2nd electronic gear when Pn005.3 is set to 1.</p>
Pn002	Binary	After restart	ALL	<p><b>Pn002.0 Electronic gear switching mode</b>            [0] Corresponding time sequence</p>

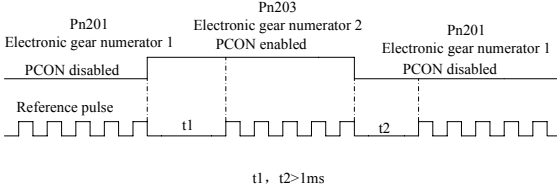
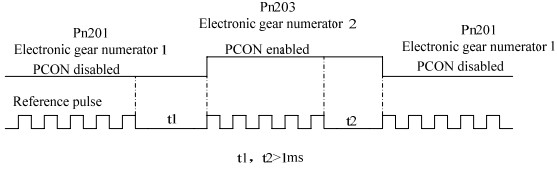
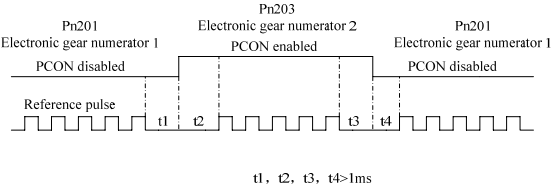
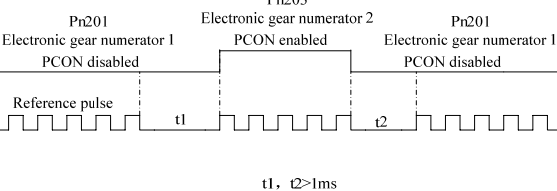
Parameter No.	Description	Setting Validation	Control Mode	Function and Meaning
				 <p data-bbox="933 537 1292 571">[1] Corresponding time sequence</p>  <p data-bbox="933 784 1340 817">Time sequence when Pn002.0=0 or 1</p>  <p data-bbox="933 1075 1157 1108">Error time sequence</p>  <p data-bbox="933 1321 1141 1355"><b>Pn002.1 Reserved</b></p> <p data-bbox="933 1366 1141 1400"><b>Pn002.2 Reserved</b></p> <p data-bbox="933 1411 1141 1444"><b>Pn002.3 Reserved</b></p>
Pn003	Binary	After restart	ALL	<p data-bbox="933 1451 1141 1485"><b>Pn003.0 Reserved</b></p> <p data-bbox="933 1496 1141 1529"><b>Pn003.1 Reserved</b></p> <p data-bbox="933 1541 1332 1574"><b>Pn003.2 Low speed compensation</b></p> <p data-bbox="933 1585 1460 1731">[0] Without low speed correction [1] With low speed correction to avoid servomotor creeping, but the degree of correction is determined by the setting in Pn219.</p> <p data-bbox="933 1742 1300 1776"><b>Pn003.3 Overload enhancement</b></p> <p data-bbox="933 1787 1476 1977">[0] Without overload enhancement function [1] With overload enhancement function, which can enhance the overload capacity when servomotor exceeds the 2 times rated overload. It is used in frequent power ON/OFF occasions.</p>

Parameter No.	Description	Setting Validation	Control Mode	Function and Meaning
Pn004	Hex	After restart	Pn004.0 ALL Pn004.1 P Pn004.2 P Pn004.3 P	<p><b>Pn004.0 Stop Mode</b></p> <p>[0]Stops the servomotor by applying DB and then releases DB.</p> <p>[1]Coast to a stop.</p> <p>[2] Stops the servomotor by DB when servo OFF, stops the servomotor by plug braking when overtravel, then places it into coast (power OFF) mode.</p> <p>[3]Makes the servomotor coast to a stop state when servo OFF, stops the servomotor by plug braking when overtravel, then places it into coast (power OFF) mode.</p> <p>[4]Stops the servomotor by DB when servo OFF, stops the servomotor by plug braking when overtravel, then places it into zero clamp mode.</p> <p>[5]Makes the servomotor coast to a stop state when servo OFF, stops the servomotor by plug braking when overtravel, then places it into zero clamp mode.</p> <p><b>Pn004.1 Error counter clear mode</b></p> <p>[0]Clear error pulse when S-OFF, do not when overtravel.</p> <p>[1]Do not clear error pulse.</p> <p>[2]Clear error pulse when S-OFF or overtravel (except for zero clamp)</p> <p><b>Pn004.2 Reference pulse form</b></p> <p>[0]Sign + Pulse</p> <p>[1]CW+CCW CW + CCW</p> <p>[2]A + B (×1)</p> <p>[3]A + B (×2)</p> <p>[4]A + B (×4)</p> <p><b>Pn004.3 Inverses pulse</b></p> <p>[0]Do not inverse PULS reference and SIGN reference</p> <p>[1]Do not inverse PULS reference; Inverses SIGN reference</p> <p>[2]Inverse PULS reference; Do not inverse SIGN reference</p> <p>[3]Inverse PULS reference and SIGN reference.</p>
Pn005	Hex	After restart	Pn005.0 P, S Pn005.1 ALL Pn005.2 P	<p><b>Pn005.0 Torque feedforward form</b></p> <p>[0]Use general torque feedforward,external analog(Tref) feedforward input is invalid.</p> <p>[1]Use high-speed torque feedforward,external analog(Tref) feedforward input is valid.</p> <p>[2]Use high-speed torque feedforward,external analog(Tref) feedforward input is invalid.</p> <p>[3]Use general torque feedforward,external</p>

Parameter No.	Description	Setting Validation	Control Mode	Function and Meaning
				<p>analog(Tref) feedforward input is valid.</p> <p><b>Pn005.1 Control mode</b></p> <p>[0]Speed control(analog reference)  <b>PCON: OFF, PI control; ON, P control</b></p> <p>[1]Position control(pulse train reference)  <b>PCON: OFF, PI control; ON, P control</b></p> <p>[2]Torque control(analog reference)  <b>PCON is invalid.</b></p> <p>[3]Speed control(contact reference)←→speed control(zero reference)  <b>PCON, PCL, NCL: OFF Switches to position control(zero reference)</b></p> <p>[4]Speed control(contact reference)←→speed control(analog reference)  <b>PCON, PCL, NCL: OFF Switches to position control(analog reference)</b></p> <p>[5]Speed control(contact reference)←→position control(pulse train reference)  <b>PCON, PCL, NCL: OFF Switches to position control(pulse train reference)</b></p> <p>[6]Speed control(contact reference)←→torque control(analog reference)  <b>PCON, PCL, NCL: OFF Switches to position control(analog reference)</b></p> <p>[7]Position control(pulse train reference)←→speed control(analog reference)  <b>PCON: OFF position control(pulse train reference); ON speed control(analog reference)</b></p> <p>[8]Position control(pulse train reference)←→Torque control(analog reference)  <b>PCON: OFF position control(pulse train reference); ON torque control(analog reference)</b></p> <p>[9]Torque control(analog reference)←→speed control(analog reference)  <b>PCON: OFF Torque control(analog reference); ON Speed control(analog reference)</b></p> <p>[A]Speed control(analog reference)←→zero clamp Control  <b>PCON: OFF Speed control(analog reference); ON zero clamp control</b></p> <p>[B]Positin control(pulse train reference)←→position control(INHIBIT)  <b>PCON: OFF Position control(pulse train reference); ON position control(INHIBIT)</b></p>

Parameter No.	Description	Setting Validation	Control Mode	Function and Meaning
				[C]Position control(contact reference) <b>P CON: Used to change step</b> <b>PCL, NCL: Used to search reference point or start</b> [D]Speed control(parameter reference) <b>P CON, PCL, NCL invalid</b> [E ]Special control <b>P CON invalid</b> <b>Pn005.2 Out-of-tolerance alarm selection</b> [0]Out-of-tolerance alarm disabled [1]Out-of-tolerance alarm enabled. Outputs alarm when the value of error counter exceeds Pn504 setting value. [2] Reserved [3] Reserved <b>Pn005.3 Servomotor model selection</b> [0]EMJ [1]EMG [2]EML [3]EMB
Pn006	Hex	After restart		<b>Pn006.0 Bus type selection</b> [0]No bus [1]PROFIBUS-DP V0/V1 [2]PROFIBUS-DP V2 [3] CANopen <b>Pn006.1 Reserved</b> <b>Pn006.2 Low-frequency vibration suppression switch</b> [0]Low-frequency vibration suppression function disabled [1]Low-frequency vibration suppression function enabled <b>Pn006.3 Reference input filter for open collector signal</b> <b>When Pn840.0=6</b> [0] when pulse is difference input, servo receiving pulse frequency $\leq 700K$ [1] when pulse is difference input, servo receiving pulse frequency $\leq 200K$ [2] when pulse is difference input, servo receiving pulse frequency $\leq 60K$
Pn007	Binary	After restart		Pn007.0: wider the width of C pulse or not [0] standard width of C pulse [1] wider the width of C pulse Pn007.1: reserved

Parameter No.	Description	Setting Validation	Control Mode	Function and Meaning
				Pn007.2: reserved Pn007.3: reserved
Pn100	Online autotuning setting	After restart	P, S	[0] Manual gain adjustment [1,2,3] Normal mode [4,5,6] Vertical load [1,4] Load inertia without variation [2,5] Load inertia with little variation [3,6] Load inertia with great variation <b>Note:</b> 1.Autotuning is invalid when servomotor max.speed is less than 100rpm.Manual gain adjustment is used. 2.Autotuning is invalid when servomotor acceleration /deceleration speed is less than 5000rpm/s. Manual gain adjustment is used. 3.Autotuning is invalid when mechanical clearance is too big during operation. Manual gain adjustment is used. 4.Autotuning is invalid when the difference of different speed load is too great. Manual gain adjustment is used.
Pn101	Machine rigidity setting	Immediately	P, S	The response speed of servo system is determined by this parameter. Normally, the rigidity should be set a little larger. However, if it is too large, it would suffer mechanical impact. It should be set a little smaller when large vibration is present. This parameter is only valid in autotuning.
Pn102	Speed loop gain	Immediately	P, S	This parameter determines speed loop gain. Unit: Hz
Pn103	Speed loop integral time constant	Immediately	P, S	Decreases the value of this parameter to shorten positioning time and enhance speed response. Unit: 0.1ms
Pn104	Position loop gain	Immediately	P	This parameter determines position loop gain. Decreases this value to enhance servo rigidity, but vibration will occur if the value is too large. Unit: 1/s
Pn105	Torque reference filter time constant	Immediately	P, S, T	Torque reference filter can eliminate or lighten mechanical vibration. But incorrect setting will result to mechanical vibration. Unit:0.1ms
Pn106	Load inertia percentage	Immediately	P, S	Setting value=(load inertia/rotor inertia) × 100 Unit: %
Pn107	2nd speed loop gain	Immediately	P, S	The meanings of these parameters are the same as Pn102~Pn105. These parameters are only needed to set when two
Pn108	2nd speed loop integral time constant	Immediately	P, S	



Parameter No.	Description	Setting Validation	Control Mode	Function and Meaning
Pn109	2nd position loop gain	Immediately	P	types of gain function are enabled.
Pn110	2nd torque reference filter time constant	Immediately	P, S, T	
Pn111	Speed bias	Immediately	P	<p>This parameter setting can shorten positioning time. However, if it is too large or does not cooperate with Pn111 correctly, vibration will occur. The relationship with speed reference, error counter, positioning error is shown in the following chart.</p>
Pn112	Feedforward	Immediately	P	<p>It is used to set position feedforward. The response speed is faster and position error is less when this parameter setting is higher. Vibration will occur if the value is set too large. Unit: %</p>
Pn113	Feedforward filter	Immediately	P	<p>It is used to ease mechanical vibration due to position feedforward. The feedforward lag will be enlarged and result to vibration if the value is set too large. Unit: 0.1ms</p>
Pn114	Torque feedforward	Immediately	P, S	<p>It is used to set torque feedforward, and enhance response speed. Set the load inertia percentage(Pn106) correctly to enable this function in manual gain adjustment mode. Unit: %</p>
Pn115	Torque feedforward filter	Immediately	P, S	<p>It is used to ease mechanical vibration due to torque feedforward. Unit: 0.1ms</p>
Pn116	P/PI switching condition	After restart	P, S	<p>0: Torque reference percentage 1: Value of offset counter 2: Value of acceleration speed setting 3: Value of speed setting 4: Fixed PI</p>
Pn117	Torque switching threshold	After restart	P, S	<p>Threshold of torque to switch PI control to P control. Unit: %</p>

Parameter No.	Description	Setting Validation	Control Mode	Function and Meaning
Pn118	Offset counter switching threshold	Immediately	P	Threshold of error counter to switch PI control to P control. Unit: pulse
Pn119	Setting acceleration speed switching threshold	Immediately	P, S	Threshold of acceleration speed to switch PI control to P control. Unit: 10rpm/s
Pn120	Setting speed switching threshold	Immediately	P, S	Threshold of speed to switch PI control to P control. Unit: rpm
Pn121	Gain switching condition	After restart	P, S	0:Fix to 1st group gain 1:External switch gain switching(G-SEL) 2:Torque percentage 3:Value of offset counter 4:Value of acceleration speed setting (10rpm) 5:Value of speed setting 6:Speed reference input
Pn122	Switching delay time	Immediately	P, S	Delay time of switching gain when switching condition is satisfied.
Pn123	Switch threshold level	Immediately	P, S	Gain switching trigger level
Pn124	Reserved	—	—	—
Pn125	Position gain switching time	Immediately	P	This parameter is used to smooth transition if the change of the two groups of gain is too large.
Pn126	Hysteresis switching	Immediately	P, S	This parameter is used to set the operation hysteresis of gain switching.
Pn127	Low speed detection filter	Immediately	P, S	This parameter is used to filter in low speed detection. The speed detection will be lagged if the value is too large.
Pn128	Speed gain acceleration relationship during online autotuning	Immediately	P, S	The increasing multiple of speed loop gain in the same rigidity during online autotuning. The speed loop gain is larger when this value is higher.
Pn129	Low speed correction coefficient	Immediately	P, S	The intensity of anti-friction and anti-creeping at low speed. Vibration will occur if this value is set too large.
Pn130	Friction Load	Immediately	P, S	Frictin load or fixed load compensation
Pn131	Friction compensation speed hysteresis area	Immediately	P, S	Threshold of friction compensation start
Pn132	Sticking friction load	Immediately	P, S	Sticking damp which is in direct proportion to speed.
Pn133	Reserved	—	—	—
Pn134	Reserved	—	—	—
Pn135	Reserved	—	—	—
Pn136	Reserved	—	—	—
Pn137	Reserved	—	—	—
Pn138	Reserved	—	—	—

Parameter No.	Description	Setting Validation	Control Mode	Function and Meaning
Pn139	Reserved	—	—	—
Pn140	Reserved	—	—	—
Pn141	Reserved	—	—	—
Pn142	Reserved	—	—	—
Pn143	Reserved	—	—	—
Pn144	Reserved	—	—	—
Pn200	PG divided ratio	After restart	P, S, T	Analog encoder output orthogonal difference pulses. The meaning of this value is the number of analog encoder output orthogonal difference pulses per one servomotor rotation.
Pn201	1st electronic gear numerator	After restart	P	The electronic gear enables the reference pulse relate with the servomotor travel distance, so the host controller need not to care mechanical deceleration ratio and encoder pulses.In fact it is the setting of frequency doubling or frequency division to the reference pulses . $\frac{\text{Numerator}(Pn201 \text{ or } Pn203)}{\text{Denominator}(Pn202)}$
Pn202	Electronic gear denominator	After restart	P	
Pn203	2nd electronic gear numerator	After restart	P	
Pn204	Position reference acceleration /deceleration time constant	Immediately	P	This value is used to smooth the input pulses. The effect of smoothness is better when the value is higher. But lag will occur if the value is too large.
Pn205	Position reference filter form selection	After restart	P	[0]: 1st order filter [1]: 2nd order filter
Pn300	Speed reference input gain	Immediately	S	The corresponding speed to 1V analog input
Pn301	Analog speed given zero bias	Immediately	S	This parameter is used to set zero bias of analog speed given, and it is related with speed reference input gain (Pn300), Speed reference=(External speed given input analog-Analog speed given zero bias) × Speed reference input gain
Pn302	Reserved	—	—	—
Pn303	Reserved	—	—	—
Pn304	Parameter speed	Immediately	S	The parameter can be set to positive or negative. When control mode is set to D, it determines the speed of motor The servomotor speed is determined by this parameter when Pn005.1=D
Pn305	JOG speed	Immediately	S	It is used to set JOG rotation speed, and the direction is determined by the pressing key during JOG operation.
Pn306	Soft start acceleration time	Immediately	S	The time for trapeziform acceleration to accelerate to 1000rpm.

Parameter No.	Description	Setting Validation	Control Mode	Function and Meaning																																	
				Unit: ms																																	
Pn307	Soft start deceleration time	Immediately	S	The time for trapeziform deceleration to decelerate to 1000rpm. Unit: ms																																	
Pn308	Speed filter time constant	Immediately	S	1st order filter time constant Unit: ms																																	
Pn309	S curve risetime	Immediately	S	The time for transition from one point to another point in S curve.																																	
Pn310	Speed reference curve form	After restart	S	0:Slope 1:S curve 2:1 <sup>st</sup> order filter 3:2 <sup>nd</sup> order filter																																	
Pn311	S form selection	After restart	S	This value determines the transition form of S curve.																																	
Pn312	DP communication JOG speed	Immediately	P, S, T	Communication speed of bus JOG. It can be set to positive or negative.																																	
Pn313	Reserved	—	—	—																																	
Pn314	Reserved	—	—	—																																	
Pn315	Reserved	—	—	—																																	
Pn316	Speed internal 1	Immediately	S	Internal speed is enabled when Pn005.1=3~6 <table border="1" style="width: 100%; border-collapse: collapse;"> <thead> <tr> <th colspan="3">Input signal</th> <th rowspan="2">operating speed</th> </tr> <tr> <th>/P-CON</th> <th>/P-CL</th> <th>/N-CL</th> </tr> </thead> <tbody> <tr> <td rowspan="4">OFF(H)</td> <td>OFF(H)</td> <td>OFF(H)</td> <td>Zero speed or switch</td> </tr> <tr> <td>OFF(H)</td> <td>ON(L)</td> <td>SPEED1</td> </tr> <tr> <td>ON(L)</td> <td>OFF(H)</td> <td>SPEED2</td> </tr> <tr> <td>ON(L)</td> <td>ON(L)</td> <td>SPEED3</td> </tr> <tr> <td rowspan="4">ON(L)</td> <td>OFF(H)</td> <td>OFF(H)</td> <td>SPEED4</td> </tr> <tr> <td>OFF(H)</td> <td>ON(L)</td> <td>SPEED5</td> </tr> <tr> <td>ON(L)</td> <td>OFF(H)</td> <td>SPEED6</td> </tr> <tr> <td>ON(L)</td> <td>ON(L)</td> <td>SPEED7</td> </tr> </tbody> </table>	Input signal			operating speed	/P-CON	/P-CL	/N-CL	OFF(H)	OFF(H)	OFF(H)	Zero speed or switch	OFF(H)	ON(L)	SPEED1	ON(L)	OFF(H)	SPEED2	ON(L)	ON(L)	SPEED3	ON(L)	OFF(H)	OFF(H)	SPEED4	OFF(H)	ON(L)	SPEED5	ON(L)	OFF(H)	SPEED6	ON(L)	ON(L)	SPEED7
Input signal			operating speed																																		
/P-CON	/P-CL	/N-CL																																			
OFF(H)	OFF(H)	OFF(H)	Zero speed or switch																																		
	OFF(H)	ON(L)	SPEED1																																		
	ON(L)	OFF(H)	SPEED2																																		
	ON(L)	ON(L)	SPEED3																																		
ON(L)	OFF(H)	OFF(H)	SPEED4																																		
	OFF(H)	ON(L)	SPEED5																																		
	ON(L)	OFF(H)	SPEED6																																		
	ON(L)	ON(L)	SPEED7																																		
Pn317	Speed internal 2	Immediately	S																																		
Pn318	Speed internal 3	Immediately	S																																		
Pn319	Speed internal 4	Immediately	S																																		
Pn320	Speed internal 5	Immediately	S																																		
Pn321	Speed internal 6	Immediately	S																																		
Pn322	Speed internal 7	Immediately	S																																		
Pn400	Torque reference gain	Immediately	T	The meaning of this parameter is the needed analog input voltage to reach the rated torque.																																	
Pn401	Forward torque internal limit	Immediately	P, S, T	Servomotor output torque limit value																																	
Pn402	Reverse torque internal limit	Immediately	P, S, T	Servomotor output torque limit value																																	
Pn403	Forward external torque limit	Immediately	P, S, T	Servomotor output torque limit value																																	
Pn404	Reverse external torque limit	Immediately	P, S, T	Servomotor output torque limit value																																	
Pn405	Plug braking torque limit	Immediately	P, S, T	Servomotor output torque limit value																																	

Parameter No.	Description	Setting Validation	Control Mode	Function and Meaning	
Pn406	Speed limit during torque control	Immediately	T	Servomotor output torque limit value during torque control	
Pn407	Notch filter 1 frequency	Immediately	P, S, T	Notch filter 1 frequency	1. In some conditions, vibration will be picked up and response will be lagged after notch filter is set. 2. When notch filter frequency is set to 5000, the notch filter is invalid.
Pn408	Notch filter 1 depth	Immediately	P, S, T	Notch filter 1 depth	
Pn409	Notch filter 2 frequency	Immediately	P, S, T	Notch filter 2 frequency	
Pn410	Notch filter 2 depth	Immediately	P, S, T	Notch filter 2 depth	
Pn411	Low frequency vibration frequency	Immediately	P, S	Frequency of low frequency vibration with load.	
Pn412	Low frequency vibration damp	Immediately	P, S	Attenuation damp of low frequency vibration with load. It does not need to change.	
Pn413	Torque control delay time	Immediately	T	These parameters are only enabled in position control mode.	
Pn414	Torque control speed hysteresis	Immediately	T		
Pn415	Analog torque given zero bias	Immediately	T	This parameter is used to set zero bias of analog torque given, and it is related with torque reference input gain (Pn400), Torque reference=(External torque given input analog-Analog torque given zero bias) × Torque reference input gain	
Pn500	Positioning error	Immediately	P	Outputs /COIN signal when error counter is less than this value.	
Pn501	Coincidence difference	Immediately	P	Outputs /VCMP signal when the difference between speed reference value and speed feedback value is less than this value.	
Pn502	Zero clamp speed	Immediately	S	The servomotor is locked in the form of temporary position loop when the speed corresponding to the analog input is less than this value.	
Pn503	Rotation detection speed TGON	Immediately	P, S, T	When the servomotor speed exceeds this parameter setting value, it means that the servomotor has already rotated steadily and outputs /TGON signal.	
Pn504	Offset counter overflow alarm	Immediately	P	When the value in error counter exceeds this parameter setting value, it means that error counter alarm has occurred and outputs alarm signal.	
Pn505	Servo ON waiting time	Immediately	P, S, T	These parameters are only enabled when the port output parameters are allocated with /BK signal output. These parameters are used to keep braking (prevent	

Parameter No.	Description	Setting Validation	Control Mode	Function and Meaning
Pn506	Basic waiting flow	Immediately	P, S, T	from gravity glissade or continuous outside force on servomotor) time sequence. <b>Servo ON waiting time:</b> ①For the parameter is plus,/BK signal is output firstly when servo-ON signal is input, and then servomotor excitation signal is created after delaying the parameter setting time. ②For the parameter is minus, servomotor excitation signal is output firstly when servo-ON signal is input, and then /BK signal is created after delaying the parameter setting time.
Pn507	Brake waiting speed	Immediately	P, S, T	
Pn508	Brake waiting time	Immediately	P, S, T	<b>Basic waiting flow:</b> Standard setting: /BK output (braking action) and servo-OFF are at the same time. Now, the machine movable part may shift slightly due to gravity according to mechanical configuration and character. But it can be eliminated by using parameters which are only enabled when the servomotor is stop or at low speed. <b>Brake waiting speed:</b> /BK signal is output when the servomotor speed is decreased to the below of this parameter setting value at servo-OFF. <b>Brake waiting time:</b> BK signal is output when the delay time exceeds the parameter setting value after servo-OFF. /BK signal is output as long as either of the brake waiting speed or brake waiting time is satisfied.
Pn509	Allocate input port to signal, one port with four bits(hex)	After restart	P, S, T	Pn509.0 corresponding port CN1_14 Pn509.1 corresponding port CN1_15 Pn509.2 corresponding port CN1_16 Pn509.3 corresponding port CN1_17
Pn510	Allocate input port to signal, one port with four bits(hex)	After restart	P, S, T	Pn510.0 corresponding port CN1_39 Pn510.1 corresponding port CN1_40 Pn510.2 corresponding port CN1_41 Pn510.3 corresponding port CN1_42 Terminal PRI : CN1_14< CN1_15< CN1_16< CN1_17< CN1_39< CN1_40< CN1_41< CN1_42 Corresponding signal of each data is shown as following: 0: S-ON 1: P-CON 2: P-OT

Parameter No.	Description	Setting Validation	Control Mode	Function and Meaning
				3: N-OT 4: ALMRST 5: CLR 6: P-CL 7: N-CL 8: G-SEL 9: JDPOS-JOG+ A: JDPOS-JOG- B: JDPOS-HALT C: HmRef D: SHOM E: ORG
Pn511	Output signal allocation	After restart	P, S, T	Pn511.0 corresponding port CN1_11, CN1_12 Pn511.1 corresponding port CN1_05, CN1_06 Pn511.2 corresponding port CN1_09, CN1_10 Corresponding signal of each data is shown as follows: 0: /COIN/VCMP 1: /TGON 2: /S-RDY 3: /CLT 4: /BK 5: /PGC 6: OT 7: /RD 8: /HOME
Pn512	Bus control input node low-bit enabled	Immediately	P, S, T	Bus communication input port enabled: [0]: Disabled [1]: Enabled Pn512.0→CN1_14 Pn512.1→CN1_15
Pn513	Bus control input node low-bit enabled	Immediately	P, S, T	Pn512.2→CN1_16 Pn512.3→CN1_17 Pn513.0→CN1_39 Pn513.1→CN1_40 Pn513.2→CN1_41 Pn513.3→CN1_42
Pn514	Input port filter	Immediately	P, S, T	It is used to set input port filter time. The signal will be lagged if the parameter setting is too high.
Pn515	Reserved		P, S, T	

Parameter No.	Description	Setting Validation	Control Mode	Function and Meaning
Pn516	Input port signal inversion	Immediately	P, S, T	[0]: Do not inverse signal. [1]: Inverse signal Pn516.0→CN1_14 inversion Pn516.1→CN1_15 inversion Pn516.2→CN1_16 inversion
Pn517	Input port signal inversion	Immediately	P, S, T	Pn516.3→CN1_17 inversion Pn517.0→CN1_39 inversion Pn517.1→CN1_40 inversion Pn517.2→CN1_41 inversion Pn517.3→CN1_42 inversion
Pn518	Reserved	Immediately	P, S, T	For factory using
Pn519	Reserved	Immediately	P, S, T	For factory using
Pn520	Reserved	Immediately	P	For factory using
Pn521	Binary	Immediately	P,S,T	If connect externally regenerative resistor 0: connect externally regenerative resistor between B1 and B2 1: dose not connect externally regenerative resistor, relay on internal capacitance. ( This parameter is in effect only on ProNet-E-02/04 )
Pn522	Reserved	—	—	—
Pn523	Reserved	—	—	—
Pn524	Reserved	—	—	—
Pn525	Overload alarm threshold	Immediately	P, S, T	When load percentage larger than overload alarm threshold, A04 will occur soon. Pn525 is recommended to set below 120, otherwise the servo drive and motor will be damaged.
Pn600	JPOS0 Position pulse in point to point control	Immediately	P	The two parameters are used in combination, and the algebraic sum of them is the position of JPOS0 needs to reach.(The number of servomotor rotation revolutions is related with the programme mode of point to point control.) Pn600 Unit: 10000P Pn601 Unit: 1P
Pn601	JPOS0 Position pulse in point to point control	Immediately	P	
	.....			
Pn630	JPOS15 Position pulse in point to point control	Immediately	P	The two parameters are used in combination, and the algebraic sum of them is the position of JPOS0 needs to reach.(The number of servomotor rotation revolutions is related with the programme mode of point to point control.)
Pn631	JPOS15 Position pulse in point to point control	Immediately	P	



Parameter No.	Description	Setting Validation	Control Mode	Function and Meaning
Pn632	JPOS0 Point to point speed control	Immediately	P	JPOS0 Point to point speed control Unit: rpm
	.....			The speed of other point to point control
Pn647	JPOS15 Point to point speed control	Immediately	P	The speed of JPOS15 point to point control Unit: rpm
Pn648	JPOS0 Point to point 1st order filter	Immediately	P	1st order filter time of JPOS0 point to point control can stop or start the servomotor mildly.
	.....			1st order filter of other point to point control.
Pn663	JPOS15 Point to point 1st order filter	Immediately	P	1st order filter time of JPOS15 point to point control can stop or start the servomotor mildly.
Pn664	JPOS0 point to point control stop time	Immediately	P	JPOS0 point to point control stop time Unit: 50ms
	.....			Other point to point control stop time
Pn679	JPOS15 point to point control stop time	Immediately	P	JPOS15 point to point control stop time Unit: 50ms
Pn680	Reserved			
Pn681	Hex	Immediately	P	<p><b>Pn681.0</b> Single/cyclic, start/reference point selection  [0]Cyclic operation, PCL start signal, NCL search reference point in forward direction.  [1]Single operation, PCL start signal, NCL search reference point in forward direction.  [2]Cyclic operation, NCL start operation, PCL search reference point in forward direction.  [3] Single operation, NCL start operation, PCL search reference point in forward direction.</p> <p><b>Pn681.1</b> Change step and start mode  [0]Delay to change step, no need of start signal, delay to start after S-ON.  [1]PCON change step, no need of start signal, PCON delay to start after S-ON, but inside pulse can not stop when PCON off.  [2]Delay to change step, need start signal, canceling start signal can immediately stop inside pulse.  Return to programme start point process step when reset.  [3]PCON change step, need start signal, canceling start signal can immediately stop inside pulse. Return to programme start point process step when reset.</p> <p><b>Pn681.2</b> Change step input signal mode  [0] Change step input signal electrical level mode  [1] Change step input signal pulse mode</p> <p><b>Pn681.3 Reserved</b></p>
Pn682	Programme mode	Immediately	P	[0]: Incremental programme [1]: Absolute programme
Pn683	Programme start step	Immediately	P	Select the start point of the point to point control

Parameter No.	Description	Setting Validation	Control Mode	Function and Meaning
Pn684	Programme stop step	Immediately	P	Select the stop point of the point to point control.
Pn685	Search travel speed in position control(contact reference); Speed of finding reference point(Hitting the origin signal ORG) in position homing control.	Immediately	P	Search the servomotor speed in the direction of reference point towards travel switch.
Pn686	Leave travel switch speed in position control(contact reference); Speed of finding reference point(Leaving the origin signal ORG) in position homing control.	Immediately	P	Search the servomotor speed when the reference point leaves travel switch.
Pn687	Position teaching pulse	Immediately	P	The two parameters are used in combination, and the algebraic sum of them is the current position of position teaching. When perform the position teaching by utility function, the algebraic sum of the two parameters are given to the current position Pn687 unit: 10000P Pn688 unit: 1P
Pn688	Position teaching pulse	Immediately	P	
Pn689	Homing Mode Setting	Immediately	P	<p><b>Pn689.0 Homing Mode</b> [0] Homing in the forward direction [1] Homing in the reverse direction</p> <p><b>Pn689.1 Search C-Pulse Mode</b> [0] Return to search C-Pulse when homing [1] Directly search C-Pulse when homing</p> <p><b>Pn689.2 Homing trigger starting mode</b> [0] Homing function disabled [1] Homing triggered by SHOM signal(rising edge)</p> <p><b>Pn689.3 Reserved</b></p>
Pn690	Number of error pulses during homing	Immediately	P	unit: 10000P
Pn691	Number of error pulses during homing	Immediately	P	unit: 1P
Pn700	Hex	After restart	ALL	<p><b>Pn700.0 MODBUS communication baud rate</b> [0] 4800bps [1] 9600bps</p>

Parameter No.	Description	Setting Validation	Control Mode	Function and Meaning
				[2] 19200bps <b>Pn700.1 MODBUS protocol selection</b> [0] 7, N, 2 (MODBUS,ASCII) [1] 7, E, 1 (MODBUS,ASCII) [2] 7, O, 1 (MODBUS,ASCII) [3] 8, N, 2 (MODBUS,ASCII) [4] 8, E, 1 (MODBUS,ASCII) [5] 8, O, 1 (MODBUS,ASCII) [6] 8, N, 2 (MODBUS,RTU) [7] 8, E, 1 (MODBUS,RTU) [8] 8, O, 1 (MODBUS,RTU) <b>Pn700.2 Communication protocol selection</b> [0] No protocol SCI communication [1] MODBUS SCI communication <b>Pn700.3 Reserved</b>
Pn701	MODBUS Axis address	After restart	ALL	Aix address of MODBUS protocol communication
Pn702	Reserved			
Pn703	CAN communication speed	After restart	ALL	<b>Pn703.0 CAN communication baud rate</b> [0] 50Kbps [1] 100Kbps [2] 125Kbps [3] 250Kbps [4] 500Kbps [5] 1Mbps
Pn704	CAN communication contact	After restart	ALL	CANopen Aix address of communication
Pn840	Hex	After restart	ALL	<b>Pn840.0</b> Encoder model selection [0]-[5] Reserved (For factory using) [6] Incremental Wire-saving Encoder (2500P/R) <b>Pn840.1</b> Reserved (For factory using) <b>Pn840.2</b> Reserved (For factory using) <b>Pn840.3</b> Reserved (For factory using)

## Appendix B

# Alarm Display

Alarm Display	Alarm Output	Alarm Name	Meaning
A. 01	×	Parameter breakdown	The checksum results of parameters are abnormal.
A. 02	×	AD shift channels breakdown	AD related electrical circuit is faulty
A. 03	×	Overspeed	The servomotor speed is excessively high and the servomotor is out of control.
A. 04	×	Overload	The servomotor is operating continuously under a torque largely exceeding ratings.
A. 05	×	Position error counter overflow	Internal counter overflow
A. 06	×	Position error pulse overflow	Position error pulse exceeded parameter(Pn504)
A. 07	×	The setting of electronic gear or given pulse frequency is not reasonable.	The setting of electronic gear is not reasonable or the given pulse frequency is too high.
A. 08	×	The 1st channel of current detection is wrong.	Something wrong with the inside chip of the 1st channel.
A. 09	×	The 2nd channel of current detection is wrong.	Something wrong with the inside chip of the 2nd channel.
A. 10	×	Incremental Encoder is break off.	At least one of Incremental Encoder PA,PB,PC is break off.
A. 12	×	Overcurrent	An overcurrent flowed through the IPM.
A. 13	×	Overvoltage	Main circuit voltage for servomotor rotation is excessively high.
A. 14	×	Undervoltage	Main circuit voltage for servomotor rotation is excessively low.
A. 15	×	Bleeder resistor error	Bleeder resistor is faulty.
A. 16	×	Regeneration error	Regenerative circuit error
A. 18	×	IGBT superheat alarm	IGBT temperature is too high.
A. 21	×	Instantaneous power off alarm	An power off for more than one period is occurred in AC.
A. 42	×	Servomotor type error	The parameter setting of servodrive does not match the servomotor.
A. 43	×	Servodrive type error	The parameter setting of servodrive does not match the servomotor.
A. 66	×	CAN communication abnormal	CAN communication is faulty because of abnormal communication connection or disturbance.
A. 67	×	Receiving heartbeat timeout	The master station sends heartbeat time timeout

<b>Alarm Display</b>	<b>Alarm Output</b>	<b>Alarm Name</b>	<b>Meaning</b>
A. 69	×	Synchronization signal monitoring cycle is longer than setting.	The filling time and the cycle of the synchronous signal does not match.
A. 00	○	Not an error	Normal operation status.

○: Output transistor is ON.

×: Output transistor is OFF.

## **ESTUN AUTOMATION TECHNOLOGY CO.,LTD**

---

ADD: 155, Jiangjun Road, Jiangning Economical & Technical  
Development Zone, Nanjing, 211100, P.R.C.

TEL: 025-52785866、52785915、52785916

FAX: 025-52785576 52785966

Web: [www.estun-servo.com](http://www.estun-servo.com)

E-mail: [info@estun.com](mailto:info@estun.com)

# ESTUN

[www.estun-servo.com](http://www.estun-servo.com)